

High-throughput screening assays for 2-(4-Chlorophenyl)-6-methylpyridine derivatives

Author: BenchChem Technical Support Team. **Date:** May 2026

Compound of Interest

Compound Name: 2-(4-Chlorophenyl)-6-methylpyridine

CAS No.: 61704-26-5

Cat. No.: B1313924

[Get Quote](#)

Application Note: HTS Assays for 2-(4-Chlorophenyl)-6-methylpyridine Derivatives Executive Summary & Scaffold Analysis

The **2-(4-Chlorophenyl)-6-methylpyridine** motif represents a "privileged scaffold" in medicinal chemistry. Its structural geometry—a central pyridine ring substituted with a lipophilic chlorophenyl group and a steric methyl blocker—mimics the bi-aryl systems found in several bioactive classes.

While this scaffold has potential applications in GPCR modulation (e.g., mGluR5 NAMs, GPR119 agonists), its most critical and clinically relevant activity lies in Topoisomerase II (Topo II) inhibition. Derivatives of this core act as interfacial poisons or catalytic inhibitors, disrupting the DNA cleavage/ligation cycle essential for cancer cell replication and bacterial survival.

Target Applications:

- Primary: Development of novel Anticancer agents (targeting Human Topo II
).
- Secondary: Antimicrobial discovery (targeting Bacterial Gyrase/Topo IV).

Screening Strategy & Workflow

To efficiently evaluate libraries of **2-(4-Chlorophenyl)-6-methylpyridine** derivatives, we employ a funnel-based screening architecture. This ensures that only compounds with true enzymatic inhibitory potential and acceptable cellular profiles progress to lead optimization.

Logical Workflow Diagram

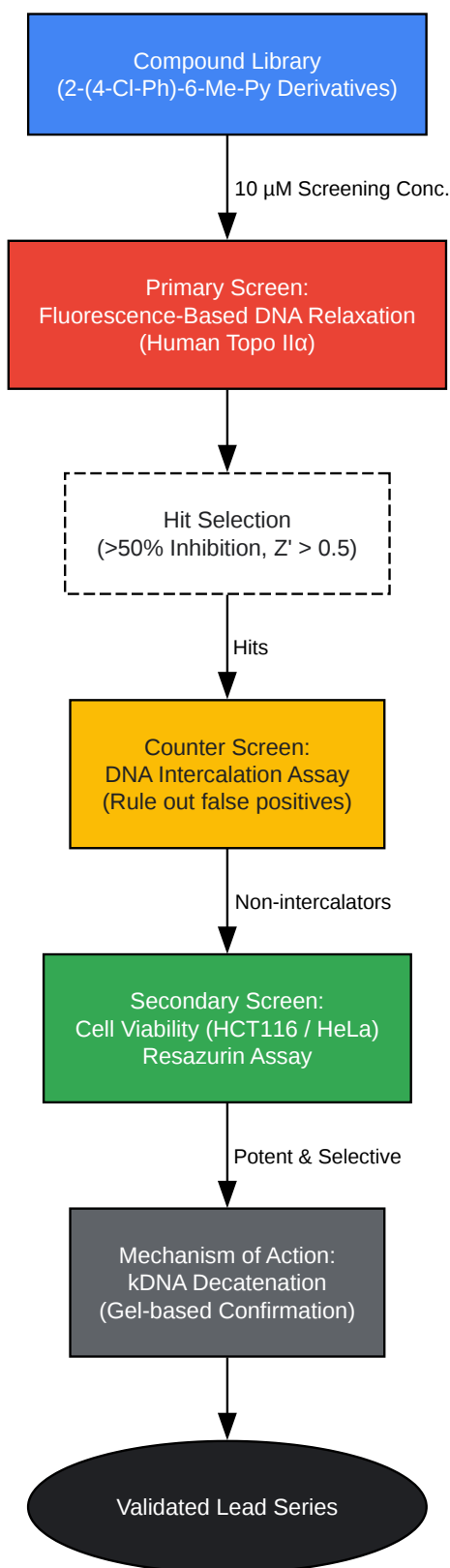

[Click to download full resolution via product page](#)

Figure 1: Triage workflow for identifying Topo II inhibitors from pyridine derivative libraries.

Primary Assay: Fluorescence-Based DNA Relaxation

Traditional gel-based assays are too slow for HTS. We utilize a high-throughput fluorescence relaxation assay.^{[1][2]} Supercoiled plasmid DNA is a substrate for Topo II. When relaxed by the enzyme, its topology changes. A fluorometric dye (e.g., SYBR Green or H19) binds differentially to supercoiled vs. relaxed DNA, allowing for a "mix-and-read" quantification.

Assay Principle

- Substrate: Supercoiled plasmid pBR322 or pAB1.
- Enzyme: Recombinant Human Topoisomerase II
- Detection: DNA-binding fluorophore.^{[1][3][4]} Relaxed DNA typically yields lower fluorescence intensity (or altered anisotropy) compared to supercoiled DNA under specific buffer conditions.
- Readout: Fluorescence Intensity (RFU).

Protocol Steps

Materials:

- 384-well Black Low-Volume Microplates (Corning #3820).
- Assay Buffer: 50 mM Tris-HCl (pH 8.0), 120 mM KCl, 10 mM MgCl₂, 5 mM ATP, 0.5 mM DTT, 30 µg/mL BSA.
- Substrate: 250 ng supercoiled pBR322 per well.
- Enzyme: 1-2 Units Human Topo II per well.

Methodology:

- **Compound Dispensing:** Acoustic dispense 50 nL of test compounds (in DMSO) into wells to achieve a final concentration of 10-50 μM . Include DMSO controls (0% inhibition) and Etoposide (100 μM , Positive Control).
- **Enzyme Addition:** Dispense 10 μL of Enzyme Mix (Topo II in Assay Buffer) using a bulk reagent dispenser (e.g., Multidrop Combi).
 - Note: Pre-incubate compound and enzyme for 10 mins if testing for direct enzyme binders.
- **Substrate Addition:** Initiate reaction by adding 10 μL of Substrate Mix (pBR322 + ATP).
- **Incubation:** Incubate at 37°C for 60 minutes.
- **Termination & Detection:** Add 20 μL of Stop/Detection Solution (1% SDS, 1x SYBR Green I in TE Buffer).
- **Read:** Incubate for 15 mins at RT in dark. Read Fluorescence (Ex 485 nm / Em 535 nm).

Data Analysis & Validity

Calculate % Inhibition relative to controls:

- **Z-Factor Requirement:** Assay is valid if
.
- **False Positive Check:** Compounds that quench SYBR Green fluorescence directly must be flagged. Run a "Compound + DNA + Dye" (no enzyme) control.

Secondary Assay: Cell-Based Cytotoxicity (HCS)

Compounds active in the biochemical assay must be validated for cellular permeability and efficacy. We use a Resazurin (Alamar Blue) Reduction Assay coupled with High-Content Screening for nuclear morphology.

Protocol Steps

- Cell Seeding: Seed HCT15 or HeLa cells (known to express Topo II) at 2,000 cells/well in 384-well clear-bottom plates. Incubate 24h.
- Treatment: Add compounds (10-point dose response, 10 μ M top conc). Incubate for 72h.
- Viability Readout: Add Resazurin reagent. Incubate 2-4h. Measure Fluorescence (Ex 560 / Em 590).
- HCS Multiplexing (Optional): Fix cells with 4% Paraformaldehyde. Stain with Hoechst 33342 (Nuclear) and anti-

H2AX (DNA Damage marker).

- Insight: True Topo II poisons (like Etoposide) will show massive upregulation of

H2AX foci. **2-(4-Chlorophenyl)-6-methylpyridine** derivatives acting as catalytic inhibitors may show cytotoxicity without the massive DNA damage signal of poisons, offering a safer therapeutic profile.

Quantitative Data Summary

| Parameter | Primary Assay (DNA Relaxation) | Secondary Assay (Cell Viability) |
|------------------|---|---|
| Format | 384-well Biochemical | 384-well Cell-based |
| Target | Human Topoisomerase II | Cellular Proliferation / DNA Integrity |
| Throughput | ~20,000 wells/day | ~10,000 wells/day |
| Signal Direction | Inhibitor = High Fluorescence (Maintains Supercoiling)* | Inhibitor = Low Fluorescence (Cell Death) |
| Key Control | Etoposide (IC ~ 50-100 μ M in relaxation) | Doxorubicin / Etoposide |
| Hit Criteria | >50% Inhibition @ 10 μ M | IC < 5 μ M |

*Note: Signal direction depends on the specific dye/topology interaction. Always verify with the specific kit instructions (e.g., ProFoldin or TopoGEN).

Scientific Rationale & Troubleshooting

Why this Scaffold? The **2-(4-Chlorophenyl)-6-methylpyridine** structure provides a rigid hydrophobic core. The 4-chlorophenyl group is critical for occupying the hydrophobic pocket of the Topo II DNA-binding groove, while the pyridine nitrogen can serve as a hydrogen bond acceptor for active site residues (e.g., Arg/Lys).

Common Pitfalls:

- Intercalation: Planar aromatic compounds can intercalate into DNA, preventing enzyme binding non-specifically.
 - Solution: Run a DNA unwinding assay.^{[1][5][6]} If the compound relaxes supercoiled DNA in the absence of enzyme, it is an intercalator (False Positive).
- Solubility: The chlorophenyl group increases lipophilicity (LogP > 3).
 - Solution: Ensure DMSO concentration in the final assay does not exceed 1% (v/v) to prevent precipitation.

References

- Topoisomerase II Screening Methodology
 - Comparison of HTS methods for Topo II inhibitors.
 - Source:
- Scaffold Biological Relevance
 - Synthesis and evaluation of 2-phenol-4-chlorophenyl-6-aryl pyridines as Topoisomerase II Inhibitors.
 - Source:
- Fluorescence Relaxation Assay Kits

- Commercial HTS kit principles (ProFoldin).
- Source:
- Cell-Based HTS Context
 - High-Throughput Screening: today's biochemical and cell-based approaches.
 - Source:

Need Custom Synthesis?

BenchChem offers custom synthesis for rare earth carbides and specific isotopic labeling.

Email: info@benchchem.com or [Request Quote Online](#).

Sources

- [1. researchgate.net \[researchgate.net\]](https://www.researchgate.net)
- [2. A high-throughput fluorescence polarization assay for inhibitors of gyrase B - PubMed \[pubmed.ncbi.nlm.nih.gov\]](https://pubmed.ncbi.nlm.nih.gov/)
- [3. New fluorescence-based high-throughput screening assay for small molecule inhibitors of tyrosyl-DNA phosphodiesterase 2 \(TDP2\) - PMC \[pmc.ncbi.nlm.nih.gov\]](https://pubmed.ncbi.nlm.nih.gov/)
- [4. DNA relaxation assay kit \[profoldin.com\]](https://www.profoldin.com/)
- [5. topogen.com \[topogen.com\]](https://www.topogen.com/)
- [6. High Throughput Screening Assays - Amerigo Scientific \[amerigoscientific.com\]](https://www.amerigoscientific.com/)
- To cite this document: BenchChem. [High-throughput screening assays for 2-(4-Chlorophenyl)-6-methylpyridine derivatives]. BenchChem, [2026]. [Online PDF]. Available at: [<https://www.benchchem.com/product/b1313924/docs#high-throughput-screening-assays-for-2-4-chlorophenyl-6-methylpyridine-derivatives>]

Disclaimer & Data Validity:

The information provided in this document is for Research Use Only (RUO) and is strictly not intended for diagnostic or therapeutic procedures. While BenchChem strives to provide

accurate protocols, we make no warranties, express or implied, regarding the fitness of this product for every specific experimental setup.

Technical Support: The protocols provided are for reference purposes. Unsure if this reagent suits your experiment?

Need Industrial/Bulk Grade? [Request Custom Synthesis Quote](#)

BenchChem

Our mission is to be the trusted global source of essential and advanced chemicals, empowering scientists and researchers to drive progress in science and industry.

Contact

Address: 3281 E Guasti Rd

Ontario, CA 91761, United States

Phone: (601) 213-4426

Email: info@benchchem.com

[Contact our Ph.D. Support Team for a compatibility check](#)