

Advanced Application Note: BDP TMR Amine in Flow Cytometry

Author: BenchChem Technical Support Team. **Date:** April 2026

Compound of Interest

Compound Name: *BDPTMRamine*

Cat. No.: *B13129261*

[Get Quote](#)

Executive Summary

This guide details the technical integration of BDP TMR Amine (a BODIPY-TMR analog) into high-parameter flow cytometry workflows. Unlike standard antibody-conjugates, BDP TMR Amine is a chemical building block primarily used to synthesize custom fluorescent probes. Its primary utility lies in conjugating to carboxyl-containing ligands, drugs, peptides, or glycans to track receptor occupancy, drug internalization, or metabolic activity.

Key Advantages:

- **Photostability:** Significantly higher than Phycoerythrin (PE) or standard TMR/TAMRA, allowing for rigorous washing and intracellular staining without signal loss.
- **Brightness:** High quantum yield (~0.[1][2][3][4][5]95) ensures detection of low-abundance targets.
- **Spectral Precision:** Narrow emission spectrum reduces spillover into the PE-Texas Red or ECD channels, facilitating multiplexing.

Technical Specifications & Spectral Logic

Physicochemical Properties

Property	Value	Notes
Fluorophore Core	Boron-dipyrromethene (BODIPY)	Hydrophobic core; requires organic co-solvent for conjugation.
Excitation Max	542–545 nm	Optimal: 561 nm (Yellow-Green Laser). Functional: 532 nm.
Emission Max	570–574 nm	Detect in PE or TRITC channel (e.g., 582/15 nm filter).
Quantum Yield	~0.90 – 0.95	Exceptional brightness for a small molecule dye.
Reactive Group	Primary Amine (-NH ₂)	Reacts with Carboxyls (via EDC/NHS), Aldehydes (Reductive Amination), or NHS-Esters.
Solubility	DMSO, DMF, Methanol	Insoluble in water; must be dissolved in organic solvent before adding to aqueous buffer.

Spectral Configuration Strategy

BDP TMR is a "Goldilocks" dye for the 561 nm laser. It fills the gap between Green (FITC/GFP) and Far-Red (APC) without the massive bulk of Phycoerythrin (PE).

Spillover Matrix:

- Primary Detector: 561 nm Ex → 585/15 nm Em (PE Channel).
- Major Spillover: Minimal spillover into PE-Cy5 or PE-Cy7 due to narrow emission.
- Cross-Excitation: Weakly excited by 488 nm laser (~30% efficiency). Critical: If co-staining with PE, ensure proper compensation, though BDP TMR is much smaller and often used for

different targets (e.g., intracellular drugs vs. surface markers).

Application: Synthesizing a Flow Cytometry Probe

Scenario: You possess a small molecule drug or peptide with a free Carboxyl group (-COOH) and wish to create a fluorescent probe to measure receptor binding in live cells.

Bioconjugation Protocol (Carboxyl-to-Amine)

Mechanism: Carbodiimide crosslinker (EDC) activates the carboxyl group on your ligand, forming an unstable O-acylisourea intermediate. NHS stabilizes this into an amine-reactive ester, which is then attacked by the BDP TMR Amine.

Reagents Required[\[5\]](#)[\[6\]](#)[\[7\]](#)[\[8\]](#)

- Target Molecule: Peptide/Drug with -COOH (free of primary amines if possible).
- Fluorophore: BDP TMR Amine (dissolved in anhydrous DMSO).
- Crosslinkers: EDC (1-Ethyl-3-(3-dimethylaminopropyl)carbodiimide) and NHS (N-Hydroxysuccinimide).
- Buffer: MES Buffer (100 mM, pH 6.0) for activation; PBS (pH 7.4) for reaction.
- Solvent: Anhydrous DMSO or DMF.

Step-by-Step Workflow

Step 1: Solubilization

- Dissolve BDP TMR Amine in anhydrous DMSO to 10 mM.
- Dissolve Target Molecule in appropriate solvent (DMSO or Buffer) to 1–5 mg/mL.

Step 2: Activation (The "Zero-Length" Crosslink)

- In a microcentrifuge tube, mix the Target Molecule with 10 molar equivalents of EDC and 25 molar equivalents of NHS in MES buffer (pH 6.0).

- Note: Activation at pH 6.0 is crucial for EDC efficiency.
- Incubate for 15 minutes at Room Temperature (RT).

Step 3: Conjugation

- Adjust pH to 7.2–7.5 using concentrated PBS or bicarbonate.
- Add 1.2 molar equivalents of BDP TMR Amine to the activated target.
- Critical: Ensure the final organic solvent concentration is <20% to prevent precipitation, unless the target is also hydrophobic.
- Incubate for 2 hours at RT in the dark.

Step 4: Purification (Mandatory)

- Small Molecules (<2 kDa): Use HPLC (C18 column) to separate free dye from the conjugate. BDP TMR is hydrophobic; free dye will elute later than hydrophilic conjugates.
- Peptides/Proteins (>2 kDa): Use Desalting Columns (PD-10 or Zeba Spin) or Dialysis.

Visualization of Conjugation Logic

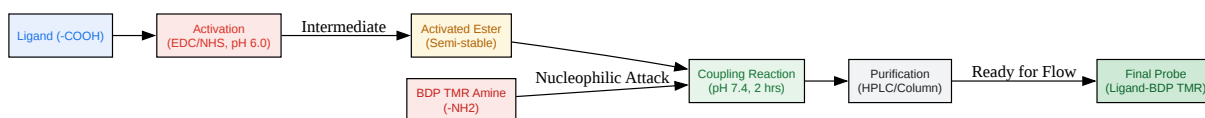

[Click to download full resolution via product page](#)

Caption: Workflow for conjugating BDP TMR Amine to a carboxyl-containing ligand via EDC/NHS chemistry.

Flow Cytometry Staining Protocol

Once the probe is synthesized, use this protocol to assess binding specificity.

Experimental Setup

- Positive Control: Cells expressing the receptor of interest.
- Negative Control: Parental cells (receptor null) or Isotype block.
- Competition Control (Critical): Pre-incubate cells with 100x excess unlabeled ligand to prove binding specificity.

Staining Steps

- Harvest Cells: Detach adherent cells using non-enzymatic buffer (e.g., EDTA) to preserve surface receptors.
- Wash: Resuspend

cells in 100 μ L Flow Buffer (PBS + 1% BSA + 0.1% NaN₃).
- Block: Incubate with Fc-block (e.g., TruStain FcX™) for 10 min on ice.
- Probe Incubation:
 - Add the BDP TMR-Ligand Probe (Titrate: start at 10–100 nM).
 - Incubate for 30–60 minutes at 4°C (to prevent internalization) or 37°C (to track internalization).
- Wash: Add 2 mL Flow Buffer, centrifuge (350 x g, 5 min), and decant. Repeat 2x.
 - Note: BDP TMR is hydrophobic.[5] If background is high, increase BSA to 2% or add 0.05% Tween-20 to the wash buffer.
- Acquisition: Analyze on a cytometer equipped with a Yellow-Green (561 nm) laser.

Data Analysis & Troubleshooting

Spectral Gating Strategy

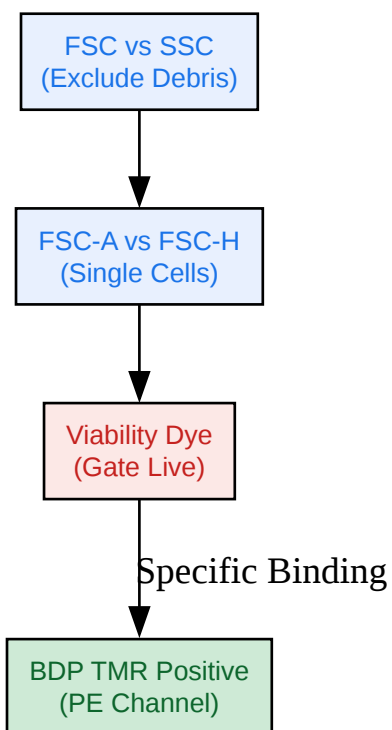

[Click to download full resolution via product page](#)

Caption: Hierarchical gating strategy to isolate single, live cells labeled with BDP TMR.

Troubleshooting Table

Issue	Probable Cause	Solution
Precipitation of Dye	Low solubility in aqueous buffer.	Dissolve BDP TMR Amine in DMSO first. Ensure final DMSO < 1% in cell suspension.
High Background	Hydrophobic non-specific binding.	Increase BSA (2-5%) in stain buffer. Perform additional washes. Titrate probe down.
No Signal	Conjugation failure or receptor absence.	Verify conjugation via Mass Spec. Use positive control cells with high receptor density.
Signal in Wrong Channel	Filter mismatch.	Ensure 561 nm excitation and ~585 nm emission filter. Avoid 488 nm excitation if possible.

References

- Lumiprobe Corporation. BDP TMR Amine Spectral Properties and Protocols.
- Hermanson, G. T. (2013). Bioconjugate Techniques (3rd Edition). Academic Press. (Standard reference for EDC/NHS chemistry).
- Thermo Fisher Scientific. Amine-Reactive Probe Chemistry.
- BroadPharm. BDP TMR Amine Product Data.

(Note: BDP® is a trademark of Lumiprobe. [4][9] Protocols should be optimized for specific cell types.)

Need Custom Synthesis?

BenchChem offers custom synthesis for rare earth carbides and specific isotopic labeling.

Email: info@benchchem.com or [Request Quote Online](#).

Sources

- [1. BDP TMR amine, 2183473-09-6 | BroadPharm \[broadpharm.com\]](#)
- [2. BDP TMR amine, 1mg | Labscoop \[labscoop.com\]](#)
- [3. Lumiprobe代理 424C0 BDP TMR amine, 25 mg | cy3 cy5 cy7荧光染料 \[lumiprobe.jinpanbio.com\]](#)
- [4. lumiprobe.com \[lumiprobe.com\]](#)
- [5. lumiprobe.com \[lumiprobe.com\]](#)
- [6. resources.tocris.com \[resources.tocris.com\]](#)
- [7. BDP TMR X NHS ester | BroadPharm \[broadpharm.com\]](#)
- [8. bmgrp.eu \[bmgrp.eu\]](#)
- [9. lumiprobe.com \[lumiprobe.com\]](#)
- To cite this document: BenchChem. [Advanced Application Note: BDP TMR Amine in Flow Cytometry]. BenchChem, [2026]. [Online PDF]. Available at: [\[https://www.benchchem.com/product/b13129261/docs#advanced-application-note-bdp-tmr-amine-in-flow-cytometry\]](https://www.benchchem.com/product/b13129261/docs#advanced-application-note-bdp-tmr-amine-in-flow-cytometry)

Disclaimer & Data Validity:

The information provided in this document is for Research Use Only (RUO) and is strictly not intended for diagnostic or therapeutic procedures. While BenchChem strives to provide accurate protocols, we make no warranties, express or implied, regarding the fitness of this product for every specific experimental setup.

Technical Support: The protocols provided are for reference purposes. Unsure if this reagent suits your experiment?

Need Industrial/Bulk Grade? [Request Custom Synthesis Quote](#)

BenchChem

Our mission is to be the trusted global source of essential and advanced chemicals, empowering scientists and researchers to drive progress in science and industry.

Contact

Address: 3281 E Guasti Rd

Ontario, CA 91761, United States

Phone: (601) 213-4426

Email: info@benchchem.com

[Contact our Ph.D. Support Team for a compatibility check](#)