

Technical Support Center: Optimizing SuFEx Reactions with Electron-Deficient Pyridines

Author: BenchChem Technical Support Team. **Date:** April 2026

Compound of Interest

Compound Name: *5,6-Dimethylpyridine-3-sulfonyl fluoride*
Cat. No.: *B13123585*

[Get Quote](#)

Welcome to the advanced troubleshooting and protocol hub for Sulfur(VI) Fluoride Exchange (SuFEx) chemistry. Electron-deficient pyridines (e.g., picolinic, nicotinic, and isonicotinic derivatives) present unique thermodynamic and polarity barriers in SuFEx workflows. Their strong electron-withdrawing nature destabilizes radical intermediates and slows down oxidative addition in downstream couplings.

This guide provides validated troubleshooting steps, mechanistic insights, and self-validating protocols for functionalizing and utilizing these challenging substrates.

Module 1: Synthesis of Pyridine SuFEx Hubs via Decarboxylative Fluorosulfonylation

Context: Converting pyridine carboxylic acids into sulfonyl fluorides (SuFEx hubs) is notoriously difficult because the electron-deficient nitrogen destabilizes the required intermediates.

FAQ: Why is my picolinic acid failing to convert to the corresponding sulfonyl fluoride under standard

conditions?

Expert Insight: Standard radical-based methods often fail because the electron-withdrawing pyridine nitrogen destabilizes the intermediate aryloxy radicals, leading to rapid degradation. To overcome this, you must employ a Copper-catalyzed Ligand-to-Metal Charge Transfer (LMCT) approach[1]. In this system, a Cu(II) carboxylate complex undergoes photo-induced homolysis. This generates an aryloxy radical and a reduced Cu(I) species in close proximity, which rapidly recombine to form the C–S bond, effectively suppressing deleterious bimolecular degradation pathways[1].

Quantitative Data: Substrate Scope & Mechanistic Causality

The following table summarizes the optimized yields for various electron-deficient pyridine cores using the LMCT method[1]:

Pyridine Core	Acid Precursor	Amine Partner (Post-SuFEx)	Yield (%)	Mechanistic Causality
Picolinic	2-Pyridinecarboxylic acid	Morpholine	45–64	Cu(II) LMCT suppresses bimolecular degradation.
Nicotinic	3-Pyridinecarboxylic acid	Piperidine	45–55	Tolerates meta-substitution; avoids radical quenching.
Isonicotinic	4-Pyridinecarboxylic acid	Diethylamine	63	Highly efficient despite extreme C4 electron deficiency.

Protocol 1: Cu-Catalyzed Decarboxylative Fluorosulfonylation

This protocol is designed to be self-validating. Do not skip the analytical checkpoints.

- **Reaction Setup:** In an oven-dried Schlenk tube, combine the pyridine carboxylic acid (1.0 equiv), Cu(OAc)₂ (10 mol%), and a fluorinating/sulfonylating agent (e.g., DABSO and Selectfluor, 1.5 equiv each).
- **Solvent & Degassing:** Add anhydrous acetonitrile (0.1 M). Degas the mixture via three consecutive freeze-pump-thaw cycles. Causality: Oxygen rapidly quenches the Cu(I) intermediate, halting the catalytic cycle.
- **Irradiation:** Irradiate the mixture with 390 nm LEDs at room temperature for 16 hours.
- **System Validation & Causality Check:** Before proceeding to purification, take a crude ¹⁹F NMR. A sharp singlet between +50 and +60 ppm validates the successful formation of the –SO₂F hub. If this peak is absent, the LMCT process was likely quenched; verify the emission wavelength of your LEDs and ensure strict anaerobic conditions.

Module 2: Direct C4-Fluorosulfonamidation via Photocatalysis

Context: Direct C–H functionalization of pyridines with SuFEx handles is highly desirable for late-stage drug functionalization.

FAQ: When attempting direct radical addition of •NSO₂F to pyridine, I observe no product. How can I overcome this thermodynamic barrier?

Expert Insight: You are experiencing a fundamental polarity mismatch. The N-centered fluorosulfonamidyl radical (•NSO₂F) is intrinsically electrophilic, and the pyridine ring is highly electron-deficient. This electrophile/electrophile mismatch prevents direct addition^[2]. To solve this, you must initiate a radical relay pathway using a heterogeneous photocatalyst (like ZnIn₂S₄) and an alkene additive^[2]. The •NSO₂F radical adds to the alkene first, generating a nucleophilic carbon-centered radical. This polarity-reversed radical readily attacks the electron-deficient pyridinium salt at the C4 position.

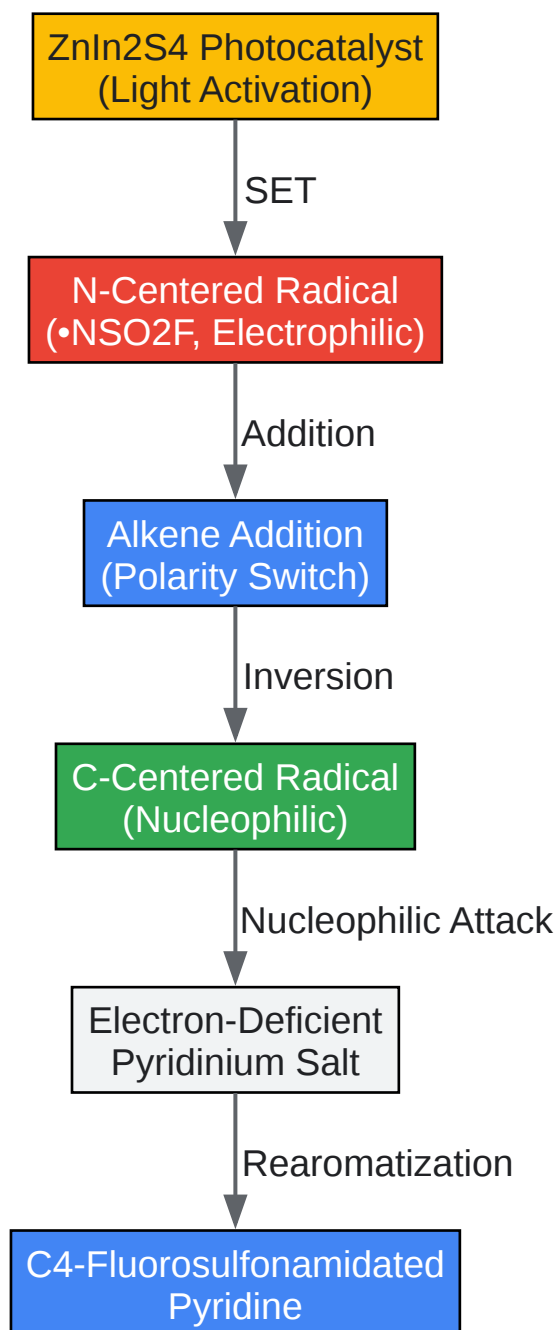

[Click to download full resolution via product page](#)

Photocatalytic radical relay for C4-fluorosulfonamidation of pyridines.

Protocol 2: Heterogeneous Photocatalytic C4 Remote Fluorosulfonamidation

- Reagent Assembly: To a transparent vial, add ZnIn₂S₄ (10 mol%), the electron-deficient pyridinium salt (1.0 equiv), N-fluorosulfamoyl salt (1.5 equiv), and an unactivated alkene (1.5

equiv).

- Solvent Addition: Suspend the mixture in a DMF/H₂O solvent system. Causality: The heterogeneous nature of ZnIn₂S₄ requires vigorous stirring to maintain light penetration.
- Photocatalysis: Irradiate with blue LEDs (450 nm) for 12 hours under a nitrogen atmosphere.
- System Validation & Causality Check: Filter the catalyst through a Celite pad. Analyze the crude mixture via LC-MS. You should observe a mass shift corresponding to the addition of both the alkene and the –SO₂F group. If only the alkene-adduct is present without the sulfonyl fluoride, the rearomatization step failed; consider adding a mild oxidant.

Module 3: Downstream Applications - Cross-Coupling PyFluor

Context: Pyridine-2-sulfonyl fluoride (PyFluor) is a potent electrophile used in Suzuki-Miyaura cross-couplings to generate 2-arylpyridines.

FAQ: My Suzuki-Miyaura cross-coupling with PyFluor yields mostly unreacted starting material. How do I optimize the catalytic cycle?

Expert Insight: PyFluor is highly electrophilic, but traditional anhydrous cross-coupling conditions often stall at the transmetalation step. Counterintuitively, the addition of water (e.g., 20% v/v in dioxane) combined with a bidentate ligand like dppf significantly enhances the yield^[3]. Water facilitates the formation of highly reactive Pd–OH intermediates, which dramatically accelerates transmetalation with the boronic acid^[3]. The robust S–F bond of PyFluor resists premature hydrolysis, allowing this "wet" chemistry to proceed flawlessly.

Quantitative Data: Optimization of PyFluor Suzuki-Miyaura Cross-Coupling

The following table demonstrates the critical role of ligand selection and water content^[3]:

Catalyst	Ligand	Solvent System	Temp (°C)	Yield (%)	Kinetic/Thermodynamic Effect
Pd(OAc) ₂	PPh ₃	Dioxane (Dry)	100	<10	Monodentate ligand fails to stabilize the oxidative addition complex.
Pd(dppf)Cl ₂	dppf	Dioxane (Dry)	100	45	Bidentate ligand improves stability, but transmetalation remains slow.
Pd(dppf)Cl ₂	dppf	Dioxane/H ₂ O (4:1)	65	78	Water forms reactive Pd–OH, accelerating transmetalation.
Pd(dppf)Cl ₂	dppf	Dioxane/H ₂ O (4:1)	100	89	Optimal thermal energy for full conversion without S–F hydrolysis.

Protocol 3: Wet Suzuki-Miyaura Cross-Coupling of PyFluor

- Reaction Assembly: Charge a 1-dram vial with PyFluor (1.0 equiv), hetero(aryl) boronic acid (1.5 equiv), Pd(dppf)Cl₂ (10 mol%), and Na₃PO₄ (3.0 equiv).

- Solvent Preparation: Add a solvent mixture of Dioxane/Water in a 4:1 ratio. Causality: Do not use molecular sieves or dry dioxane; the 20% water content is strictly required to form the Pd–OH transmetalation intermediate.
- Heating: Seal the vial and heat to 100 °C for 12 hours.
- System Validation & Causality Check: Monitor the reaction via ¹⁹F NMR. The disappearance of the PyFluor signal (approx. +55 ppm) indicates consumption of the starting material. Confirm the formation of the 2-arylpyridine product via GC-MS. If the S–F signal disappears but no product is formed, the S–F bond was hydrolyzed; verify that the temperature did not exceed 100 °C and that the base concentration was not erroneously high.

References

- Title: One-Pot Synthesis of Sulfonamides from Unactivated Acids and Amines via Aromatic Decarboxylative Halosulfonylation Source: Journal of the American Chemical Society URL: [\[Link\]](#)
- Title: Heterogeneous photocatalytic C4 remote fluorosulfonamidation of pyridines Source: Chemical Science (RSC Publishing) URL:[\[Link\]](#)
- Title: Synthesis of 2-arylpyridines by the Suzuki–Miyaura cross-coupling of PyFluor with hetero(aryl) boronic acids and esters Source: Canadian Journal of Chemistry URL:[\[Link\]](#)

Need Custom Synthesis?

BenchChem offers custom synthesis for rare earth carbides and specific isotopic labeling.

Email: info@benchchem.com or [Request Quote Online](#).

Sources

- 1. pubs.acs.org [pubs.acs.org]
- 2. Heterogeneous photocatalytic C4 remote fluorosulfonamidation of pyridines - Chemical Science (RSC Publishing) DOI:10.1039/D5SC08495D [pubs.rsc.org]
- 3. researchgate.net [researchgate.net]

- To cite this document: BenchChem. [Technical Support Center: Optimizing SuFEx Reactions with Electron-Deficient Pyridines]. BenchChem, [2026]. [Online PDF]. Available at: [<https://www.benchchem.com/product/b13123585/docs#technical-support-center-optimizing-sufex-reactions-with-electron-deficient-pyridines>]

Disclaimer & Data Validity:

The information provided in this document is for Research Use Only (RUO) and is strictly not intended for diagnostic or therapeutic procedures. While BenchChem strives to provide accurate protocols, we make no warranties, express or implied, regarding the fitness of this product for every specific experimental setup.

Technical Support: The protocols provided are for reference purposes. Unsure if this reagent suits your experiment?

Need Industrial/Bulk Grade? [Request Custom Synthesis Quote](#)

BenchChem

Our mission is to be the trusted global source of essential and advanced chemicals, empowering scientists and researchers to drive progress in science and industry.

Contact

Address: 3281 E Guasti Rd
Ontario, CA 91761, United States
Phone: (601) 213-4426
Email: info@benchchem.com

[Contact our Ph.D. Support Team for a compatibility check](#)