

A Comparative Yield Analysis: Direct vs. Two-Step Synthesis of Methylated 7-Azaindoles

Author: BenchChem Technical Support Team. **Date:** May 2026

Compound of Interest

Compound Name: *1-Methyl-1H-pyrrolo[2,3-b]pyridin-5-ol*
CAS No.: 737003-45-1
Cat. No.: B1312225

[Get Quote](#)

Introduction: The Significance of Methylated 7-Azaindoles in Modern Drug Discovery

The 7-azaindole scaffold is a privileged heterocyclic motif in medicinal chemistry, serving as a cornerstone for a multitude of therapeutic agents.^{[1][2]} Its structural resemblance to indole allows it to act as a bioisostere, often leading to improved pharmacological properties such as enhanced solubility and superior bioavailability.^[1] The introduction of a methyl group to this scaffold can significantly modulate a molecule's potency, selectivity, and metabolic stability, making the efficient synthesis of methylated 7-azaindoles a critical endeavor for drug development professionals.

This guide provides an in-depth comparative analysis of two primary synthetic strategies for accessing methylated 7-azaindoles: direct (one-pot) synthesis and two-step sequential functionalization. By examining the underlying chemical principles, experimental yields, and practical considerations of each approach, this document aims to equip researchers with the knowledge to make informed decisions in their synthetic campaigns.

Defining the Synthetic Approaches: A Tale of Two Strategies

For the purpose of this analysis, we define the two synthetic strategies as follows:

- **Direct Synthesis:** A reaction cascade or one-pot process where the methylated 7-azaindole is formed from acyclic or simpler heterocyclic precursors in a single synthetic operation. This approach aims for maximal step economy.
- **Two-Step Synthesis:** A sequential approach where a pre-formed 7-azaindole core is first functionalized (e.g., halogenated) to introduce a reactive handle, followed by a second distinct chemical transformation to install the methyl group.

The choice between these strategies is often dictated by the desired substitution pattern, the availability of starting materials, and the scalability of the reaction.

Direct Synthesis: A One-Pot Approach to 2-Methyl-7-Azaindole

A notable example of a direct synthesis of a methylated 7-azaindole is the reaction between a substituted pyridine and an aldehyde, leading to the formation of the bicyclic ring system in a single pot. This approach leverages a domino reaction sequence to achieve molecular complexity efficiently.

Mechanistic Rationale

The one-pot synthesis of 2-methyl-7-azaindole from 2-fluoro-3-methylpyridine and an arylaldehyde is a compelling example of a direct approach. The reaction is alkali-amide controlled, where the choice of the metal counterion in the base dictates the chemoselectivity of the final product.^[1] The mechanism, initiated by the deprotonation of the methyl group on the pyridine ring, proceeds through a series of tandem C-N and C-C bond formations. The use of potassium hexamethyldisilazide (KHMDs) favors the formation of the 7-azaindole over the corresponding 7-azaindoline.^[1] This selectivity is attributed to the role of the potassium cation in promoting the elimination step that leads to the aromatic 7-azaindole core.

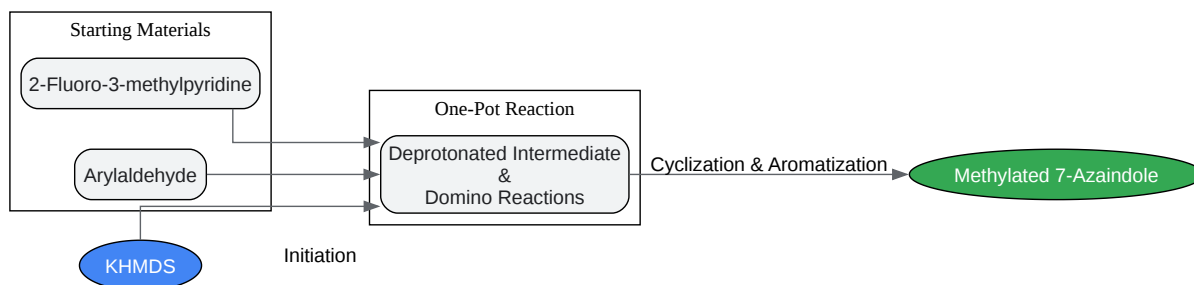

[Click to download full resolution via product page](#)

Caption: One-Pot Synthesis of Methylated 7-Azaindole.

Experimental Protocol: Direct Synthesis of a 2-Aryl-7-Azaindole Derivative

The following is a representative protocol for the direct synthesis of a 2-aryl-7-azaindole, adapted from the literature.^[1]

- To a flame-dried Schlenk tube under an argon atmosphere, add 2-fluoro-3-picoline (1.0 equiv.) and the desired arylaldehyde (1.0 equiv.).
- Add anhydrous diisopropyl ether as the solvent.
- Add potassium hexamethyldisilazide (KHMDS) (3.0 equiv.) to the solution at room temperature.
- Seal the tube and heat the reaction mixture at 110 °C for 12 hours.
- After cooling to room temperature, quench the reaction with saturated aqueous ammonium chloride solution.
- Extract the aqueous layer with ethyl acetate (3 x 20 mL).

- Combine the organic layers, dry over anhydrous sodium sulfate, filter, and concentrate under reduced pressure.
- Purify the crude product by column chromatography on silica gel to afford the desired 2-aryl-7-azaindole.

Two-Step Synthesis: A Sequential Approach to 2-Methyl-7-Azaindole

The two-step synthesis offers a more controlled and often more versatile route to methylated 7-azaindoles. A common strategy involves the initial synthesis of a halogenated 7-azaindole, which then serves as a substrate for a subsequent cross-coupling reaction to introduce the methyl group.

Mechanistic Rationale

A well-established two-step synthesis of 2-substituted 7-azaindoles commences with the Sonogashira coupling of 2-amino-3-iodopyridine with a terminal alkyne. This palladium-catalyzed reaction forms a 2-amino-3-(alkynyl)pyridine intermediate. The subsequent step involves an intramolecular cyclization to construct the pyrrole ring of the 7-azaindole. This cyclization is typically base-mediated, with potassium tert-butoxide being an effective choice.^[3] The use of a crown ether, such as 18-crown-6, can facilitate the reaction by sequestering the potassium cation, thereby increasing the nucleophilicity of the amino group.^[3] To obtain a 2-methyl-7-azaindole, propyne would be the alkyne of choice in the initial coupling step.

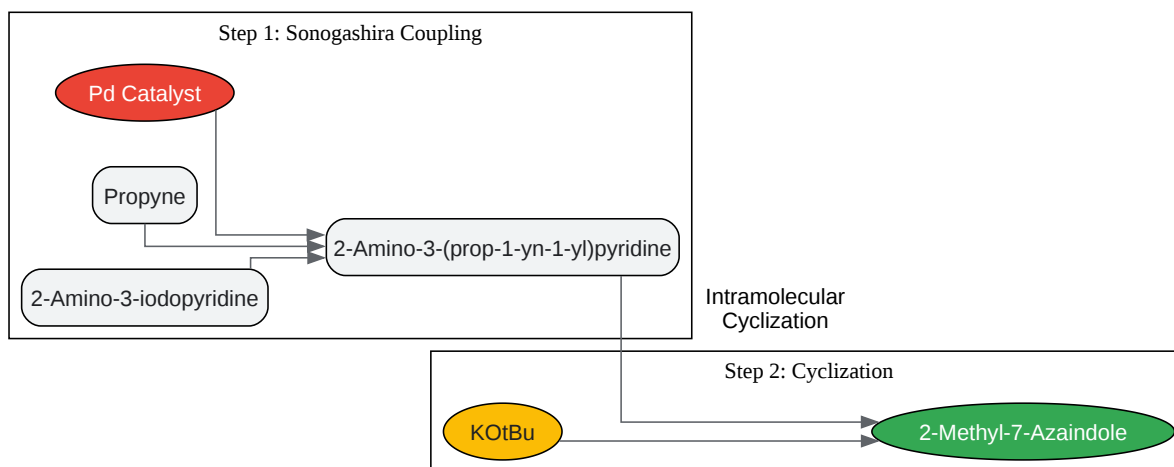

[Click to download full resolution via product page](#)

Caption: Two-Step Synthesis of 2-Methyl-7-Azaindole.

Experimental Protocol: Two-Step Synthesis of 2-Methyl-7-Azaindole

The following protocol is a representative example of a two-step synthesis of 2-methyl-7-azaindole, based on established methodologies.[3]

Step 1: Synthesis of 2-Amino-3-(prop-1-yn-1-yl)pyridine

- To a solution of 2-amino-3-iodopyridine (1.0 equiv.) in a suitable solvent such as toluene, add a palladium catalyst (e.g., Pd(PPh₃)₄, 5 mol %) and a copper(I) co-catalyst (e.g., CuI, 10 mol %).
- Add a base, such as triethylamine (2.0 equiv.).

- Bubble propyne gas through the reaction mixture at room temperature for 1-2 hours, or until the starting material is consumed as monitored by TLC.
- Filter the reaction mixture through a pad of celite and concentrate the filtrate under reduced pressure.
- Purify the crude product by column chromatography on silica gel to yield 2-amino-3-(prop-1-yn-1-yl)pyridine.

Step 2: Synthesis of 2-Methyl-7-azaindole

- Dissolve the 2-amino-3-(prop-1-yn-1-yl)pyridine (1.0 equiv.) in anhydrous toluene.
- Add potassium tert-butoxide (1.2 equiv.) and a catalytic amount of 18-crown-6 (10 mol %).
- Heat the reaction mixture at 65 °C until the starting material is fully consumed (monitored by TLC).
- Cool the reaction to room temperature and quench with water.
- Separate the organic layer, and extract the aqueous layer with ethyl acetate.
- Combine the organic layers, dry over anhydrous sodium sulfate, filter, and concentrate in vacuo.
- Purify the residue by column chromatography to obtain 2-methyl-7-azaindole.

Comparative Yield Analysis

A direct, head-to-head comparison of yields for the synthesis of the exact same methylated 7-azaindole derivative via both a direct and a two-step route is not readily available in the literature. However, we can analyze the reported yields for representative examples of each strategy to draw meaningful conclusions.

Synthetic Strategy	Key Transformation(s)	Reported Yield Range	Reference
Direct Synthesis	One-pot reaction of 2-fluoro-3-picoline and arylaldehyde	56% (for a 2-aryl-7-azaindole)	[1]
Two-Step Synthesis	1. Sonogashira coupling 2. Base-mediated cyclization	Good overall yields (specifics vary with substrates)	[3][4]
Two-Step Synthesis	1. Acylation of 2-amino-3-picoline 2. Cyclization	>60% (for 2-methyl-7-azaindole)	

Analysis of Findings:

- **Direct Synthesis:** The one-pot synthesis of a 2-aryl-7-azaindole reports a respectable yield of 56%. [1] This approach is highly efficient in terms of step economy. However, the substrate scope for the aldehyde component may influence the yield, and the direct synthesis of a simple 2-methyl-7-azaindole (using acetaldehyde or a surrogate) via this specific method is not explicitly reported with yield data.
- **Two-Step Synthesis:** While a cumulative yield for the two-step synthesis of 2-methyl-7-azaindole is not provided as a single value in the cited literature, the individual steps are reported to proceed in high yields. [3] A separate two-step method involving acylation and cyclization reports a total yield of over 60% for 2-methyl-7-azaindole. This suggests that the two-step approach can be highly effective and may offer higher overall yields in certain cases. The modularity of the two-step approach also allows for greater flexibility in introducing diverse substituents.

Expert Insights and Practical Considerations

As a Senior Application Scientist, my experience suggests that the choice between a direct and a two-step synthesis is a classic trade-off between efficiency and versatility.

- For Rapid Library Synthesis and Analogue Exploration: The two-step approach is often superior. The ability to synthesize a common intermediate, such as a halogenated 7-azaindole, and then diversify it in the second step is invaluable for structure-activity relationship (SAR) studies.
- For Large-Scale Synthesis of a Specific Target: A well-optimized direct or one-pot synthesis can be more cost-effective and generate less waste, making it an attractive option for process chemistry and manufacturing. However, the optimization of such a process can be more challenging due to the complexity of the reaction network in a single pot.
- Purity and Scalability: The two-step synthesis often provides better control over impurities, as intermediates can be purified at each stage. This can simplify the final purification and lead to a higher-purity product, which is critical in a pharmaceutical setting. While direct syntheses can be scalable, they may require more rigorous process control to manage exotherms and ensure consistent product quality.

Conclusion

Both direct and two-step synthetic strategies offer viable pathways to methylated 7-azaindoles, each with its own set of advantages and disadvantages. The direct, one-pot approach excels in step economy and can be highly efficient for specific targets. Conversely, the two-step synthesis provides greater flexibility, control, and often higher overall yields, making it a workhorse for medicinal chemistry programs. The optimal choice will ultimately depend on the specific goals of the research, the desired substitution pattern, and the scale of the synthesis. A thorough evaluation of both routes is recommended during the early stages of a drug discovery project to identify the most robust and efficient path forward.

References

- Xu, X., et al. (2022). Alkali-Amide Controlled Selective Synthesis of 7-Azaindole and 7-Azaindoline through Domino Reactions of 2-Fluoro-3-methylpyridine and Aldehydes. *Organic Chemistry Frontiers*. [[Link](#)]
- Subota, A. I., et al. (2018). Scalable synthesis and properties of 7-methyl-4-azaindole. *ResearchGate*. [[Link](#)]
- Organic Chemistry Portal. Azaindole synthesis. [[Link](#)]

- Immadi, S. S., et al. (2018). Exploring 6-Azaindole and 7-Azaindole Rings for Developing Cannabinoid Receptor 1 Allosteric Modulators. *Cannabis and Cannabinoid Research*. [[Link](#)]
- Langer, P., et al. (2011). Synthetic approaches for the synthesis of 7-azaindole derivatives using 5-amino-1R-1H-pyrrole-3-carbonitrile. *RosDok*. [[Link](#)]
- Mérour, J. Y., & Joseph, B. (2001). Synthesis and Reactivity of 7-Azaindoles (1H-Pyrrolo(2,3-b)pyridine). *Current Organic Chemistry*. [[Link](#)]
- Kharb, R., et al. (2021). Design and synthesis of Meldrum's acid based 7-azaindole anchored 1,2,3-triazole hybrids as anticancer agents. *RSC Advances*. [[Link](#)]
- Laha, J. K., et al. (2020). Recent advances in the global ring functionalization of 7-azaindoles. *Chemical Communications*. [[Link](#)]
- de Mattos, M. C., et al. (2007). Efficient Synthesis of 2-Substituted 7-Azaindole Derivatives via Palladium-Catalyzed Coupling and C-N Cyclization Using 18-Crown-6. *Synthesis*. [[Link](#)]

Need Custom Synthesis?

BenchChem offers custom synthesis for rare earth carbides and specific isotopic labeling.

Email: info@benchchem.com or [Request Quote Online](#).

Sources

- [1. pubs.rsc.org](https://pubs.rsc.org) [pubs.rsc.org]
- [2. Recent advances in the global ring functionalization of 7-azaindoles - Chemical Communications \(RSC Publishing\)](#) [pubs.rsc.org]
- [3. Efficient Synthesis of 2-Substituted 7-Azaindole Derivatives via Palladium-Catalyzed Coupling and C-N Cyclization Using 18-Crown-6](#) [organic-chemistry.org]
- [4. Azaindole synthesis](#) [organic-chemistry.org]
- To cite this document: BenchChem. [A Comparative Yield Analysis: Direct vs. Two-Step Synthesis of Methylated 7-Azaindoles]. BenchChem, [2026]. [Online PDF]. Available at: [<https://www.benchchem.com/product/b1312225/docs#a-comparative-yield-analysis-direct-vs-two-step-synthesis-of-methylated-7-azaindoles>]

Disclaimer & Data Validity:

The information provided in this document is for Research Use Only (RUO) and is strictly not intended for diagnostic or therapeutic procedures. While BenchChem strives to provide accurate protocols, we make no warranties, express or implied, regarding the fitness of this product for every specific experimental setup.

Technical Support: The protocols provided are for reference purposes. Unsure if this reagent suits your experiment?

Need Industrial/Bulk Grade? [Request Custom Synthesis Quote](#)

BenchChem

Our mission is to be the trusted global source of essential and advanced chemicals, empowering scientists and researchers to drive progress in science and industry.

Contact

Address: 3281 E Guasti Rd
Ontario, CA 91761, United States
Phone: (601) 213-4426
Email: info@benchchem.com

[Contact our Ph.D. Support Team for a compatibility check](#)