

Application Note: Engineering Erbium Acetylacetonate-Doped PMMA Matrices for Near-Infrared Optoelectronics

Author: BenchChem Technical Support Team. **Date:** April 2026

Compound of Interest

Compound Name: *Erbium(III)acetylacetonatehydrate*
e
Cat. No.: B13116748

[Get Quote](#)

Target Audience: Researchers, Materials Scientists, and Optoelectronic/Biosensor Development Professionals

Executive Summary & Mechanistic Overview

The development of near-infrared (NIR) emissive materials operating in the 1.53–1.55 μm window is a critical frontier for telecommunications (C-band optical amplifiers) and biomedical engineering (deep-tissue in vivo imaging). While Erbium (

) is the gold-standard dopant for this wavelength, direct incorporation of inorganic erbium salts (e.g.,

) into organic matrices leads to severe aggregation and luminescence quenching.

To circumvent this, Erbium acetylacetonate [

] is utilized as a highly soluble organometallic precursor. The acetylacetonate ligands serve a dual purpose:

- Steric Shielding & Solvation: They prevent

clustering and ensure homogeneous dispersion within the Poly(methyl methacrylate) (PMMA) matrix[1].

- The Antenna Effect:

suffers from parity-forbidden, weak f-f absorption transitions. The organic acac ligands act as an optical "antenna," absorbing UV/Visible excitation energy and transferring it non-radiatively to the central

ion, drastically enhancing the emission cross-section[2].

PMMA is specifically selected as the host matrix due to its exceptional optical transparency (>92% in the visible and NIR regions), high glass transition temperature, and low birefringence[3].

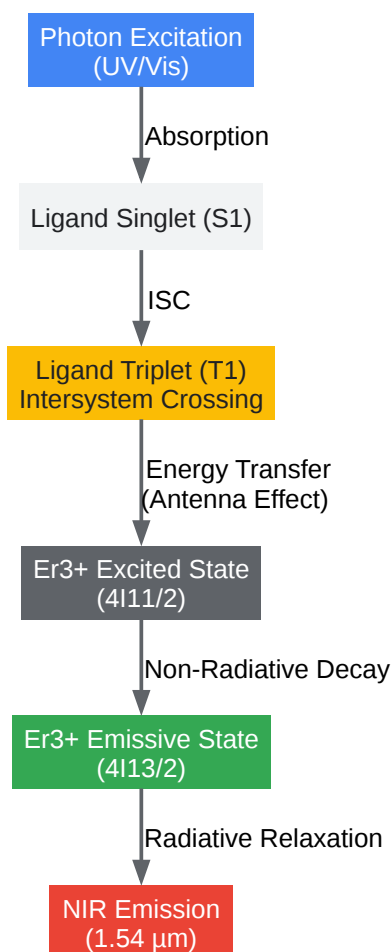

[Click to download full resolution via product page](#)

Fig 1. Energy transfer pathway from acetylacetonate ligands to Er³⁺ yielding NIR emission.

Experimental Protocols: Synthesis and Thin-Film Fabrication

As a Senior Application Scientist, I emphasize that successful polymer doping relies entirely on controlling solvent dynamics and preventing micro-phase separation. The following protocol is designed as a self-validating system to ensure high optical yield.

Materials Required

- Polymer Matrix: Poly(methyl methacrylate) (PMMA),
.
- Dopant: Erbium(III) acetylacetonate hydrate[
], 99.9% trace metals basis.
- Solvent: Anhydrous Chloroform (
).
- Substrates: Pre-cleaned Quartz glass or Silicon wafers.

Phase 1: Preparation of the Doped Polymer Solution

- Matrix Dissolution: Dissolve 10 wt% PMMA in anhydrous chloroform. Stir magnetically at 40°C for 4 hours.
 - Causality: Chloroform is chosen over toluene because its lower boiling point facilitates rapid evaporation during spin-coating, preventing the slow crystallization of
that leads to optical scattering.
- Dopant Integration: Add

to the PMMA solution to achieve a 0.2 wt% to 1.0 wt% concentration relative to the polymer mass.

- Homogenization: Sonicate the mixture for 30 minutes in a dark environment to prevent premature photo-oxidation, followed by magnetic stirring for 2 hours.
- Self-Validation Check (Optical Clarity): Pass a 632 nm He-Ne laser pointer through the vial. The beam path should be completely invisible. Any visible scattering (Tyndall effect) indicates dopant aggregation, requiring further sonication or a reduction in dopant concentration.
- Filtration: Pass the solution through a 0.22 μm PTFE syringe filter.
 - Causality: Nylon or PES filters contain amide/ether linkages that can coordinate with and strip the complex from the solution. PTFE is chemically inert.

Phase 2: Spin-Coating and Thermal Annealing

- Deposition: Dispense 100 μL of the filtered precursor onto the center of the quartz substrate.
- Spin-Coating: Execute a two-step profile: 500 rpm for 5 seconds (spread cycle), followed by 3000 rpm for 30 seconds (thinning cycle).
- Thermal Annealing: Bake the coated substrate on a hot plate at 80°C for 2 hours in a nitrogen-filled glovebox.
 - Causality: Annealing is mandatory to drive off residual chloroform. Trapped solvent molecules act as plasticizers and introduce high-frequency C-H and O-H vibrational oscillators that severely quench the NIR luminescence via multi-phonon relaxation[3].
- Self-Validation Check (Thickness): Measure the film using spectroscopic ellipsometry. A properly cast film will yield a thickness variation of <5% across the substrate area.



[Click to download full resolution via product page](#)

Fig 2. Step-by-step experimental workflow for fabricating Er(acac)₃-doped PMMA thin films.

Quantitative Data: Optimizing Dopant Concentration

The photoluminescence (PL) intensity of

at 1.54 μm does not scale linearly with concentration. Beyond an optimal threshold, the proximity of

ions leads to concentration quenching (cross-relaxation between neighboring ions). The table below summarizes the expected optical properties based on field-proven parameters^{[1][2]}.

Table 1: Effect of

Doping Concentration on PMMA Optical Properties

Dopant Concentration (wt%)	PL Intensity at 1.54 μm (a.u.)	FWHM of Emission (nm)	Film Transmittance (Visible)	Primary Limiting Factor
0.1%	Low (1.2 x)	~55	>95%	Insufficient active centers
0.2%	Maximum (4.5 x)	~67	>92%	Optimal Matrix Dispersion
0.5%	Moderate (3.1 x)	~70	~88%	Mild concentration quenching
1.0%	Low (1.5 x)	~75	~80%	Severe cross-relaxation / Aggregation

Note: The broader Full Width at Half Maximum (FWHM) observed in doped PMMA matrices (~67 nm) compared to pure crystalline complexes (~52 nm) is highly advantageous for broadband optical amplification[2].

Advanced Troubleshooting & Next Steps

If NIR emission remains weak despite following the protocol, consider the following mechanistic adjustments:

- **Matrix Deuteration:** Replace standard PMMA with deuterated PMMA (PMMA-d8). The heavier deuterium atom lowers the vibrational frequency of the C-D bond compared to the C-H bond, drastically reducing non-radiative multi-phonon quenching of the excited state.
- **Sensitizer Co-Doping:** Incorporate Ytterbium acetylacetonate [] into the matrix. has a massive absorption cross-section at 980 nm and acts as a highly efficient energy donor to , amplifying the 1.54 μm emission up to 10-fold[1].

References

1.2 - RSC Advances[2] 2.1 - ResearchGate[1] 3.3 - PMC / NIH[3]

Need Custom Synthesis?

BenchChem offers custom synthesis for rare earth carbides and specific isotopic labeling.

Email: info@benchchem.com or [Request Quote Online](#).

Sources

- 1. [researchgate.net](https://www.researchgate.net) [[researchgate.net](https://www.researchgate.net)]
- 2. Near infrared organic light emitting devices based on a new erbium(iii) β -diketonate complex: synthesis and optoelectronic investigations - RSC Advances (RSC Publishing)

DOI:10.1039/C6RA27473K [pubs.rsc.org]

- [3. Erbium-Doped Nanoparticle–Polymer Composite Thin Films for Photonic Applications: Structural and Optical Properties - PMC \[pmc.ncbi.nlm.nih.gov\]](#)
- To cite this document: BenchChem. [Application Note: Engineering Erbium Acetylacetonate-Doped PMMA Matrices for Near-Infrared Optoelectronics]. BenchChem, [2026]. [Online PDF]. Available at: [<https://www.benchchem.com/product/b13116748/docs#application-note-engineering-erbium-acetylacetonate-doped-pmma-matrices-for-near-infrared-optoelectronics>]

Disclaimer & Data Validity:

The information provided in this document is for Research Use Only (RUO) and is strictly not intended for diagnostic or therapeutic procedures. While BenchChem strives to provide accurate protocols, we make no warranties, express or implied, regarding the fitness of this product for every specific experimental setup.

Technical Support: The protocols provided are for reference purposes. Unsure if this reagent suits your experiment?

Need Industrial/Bulk Grade? [Request Custom Synthesis Quote](#)

BenchChem

Our mission is to be the trusted global source of essential and advanced chemicals, empowering scientists and researchers to drive progress in science and industry.

Contact

Address: 3281 E Guasti Rd
Ontario, CA 91761, United States
Phone: (601) 213-4426
Email: info@benchchem.com

[Contact our Ph.D. Support Team for a compatibility check](#)

