

# A Comparative Guide to the Mass Spectrometry Fragmentation Patterns of Di-brominated Pyridines

**Author:** BenchChem Technical Support Team. **Date:** April 2026

## Compound of Interest

Compound Name: 4-Bromo-2-(2-bromoethyl)pyridine

Cat. No.: B13116241

[Get Quote](#)

For Researchers, Scientists, and Drug Development Professionals

## Introduction: The Analytical Imperative of Di-brominated Pyridines

Di-brominated pyridines are a class of heterocyclic compounds of significant interest in medicinal chemistry and materials science. As crucial building blocks in the synthesis of novel pharmaceuticals and functional materials, the ability to unambiguously identify their specific isomeric forms is paramount. The substitution pattern of the two bromine atoms on the pyridine ring profoundly influences the molecule's chemical reactivity, biological activity, and physical properties.

Mass spectrometry, particularly with electron ionization (EI), stands as a cornerstone technique for the structural elucidation of these isomers. The high energy imparted by EI induces characteristic fragmentation of the molecular ion, generating a unique mass spectrum that serves as a molecular fingerprint. Understanding the nuances of these fragmentation patterns is not merely an academic exercise; it is a critical step in quality control, reaction monitoring,

and the confident identification of these important chemical entities. This guide will explore the fragmentation behavior of various di-brominated pyridine isomers, providing a comparative analysis to aid researchers in their analytical endeavors.

## Fundamental Principles of Fragmentation in Di-brominated Pyridines

The fragmentation of di-brominated pyridines under electron ionization is governed by the inherent stability of the pyridine ring, the nature of the carbon-bromine bond, and the relative positions of the two bromine atoms. The initial ionization event typically involves the removal of an electron from the nitrogen's lone pair or the  $\pi$ -system of the aromatic ring, forming a molecular radical cation ( $M^{\bullet+}$ ).<sup>[1]</sup> This high-energy species then undergoes a series of fragmentation reactions to produce a characteristic pattern of fragment ions.

Several key fragmentation processes are consistently observed across the di-brominated pyridine isomers:

- **Loss of a Bromine Radical ( $\bullet\text{Br}$ ):** This is often a primary and significant fragmentation pathway, resulting in a bromo-pyridyl cation. The relative ease of this cleavage is influenced by the stability of the resulting cation.
- **Loss of a Hydrogen Bromide Molecule (HBr):** This fragmentation involves the elimination of HBr, often through a rearrangement process. The propensity for this loss can be influenced by the proximity of a bromine atom to a ring hydrogen.
- **Cleavage of the Pyridine Ring:** The stable aromatic ring can also fragment, although this typically requires higher energy. Common ring cleavage pathways for pyridine derivatives involve the loss of acetylene ( $\text{C}_2\text{H}_2$ ) or hydrogen cyanide (HCN) from various intermediate ions.<sup>[2]</sup>
- **Isotopic Peaks:** A crucial feature in the mass spectra of brominated compounds is the presence of characteristic isotopic peaks. Bromine has two stable isotopes,  $^{79}\text{Br}$  and  $^{81}\text{Br}$ , in nearly equal abundance (approximately 50.7% and 49.3%, respectively).<sup>[3]</sup> This results in a distinctive  $M$ ,  $M+2$ , and  $M+4$  pattern for the molecular ion and any bromine-containing fragments, which is invaluable for confirming the presence and number of bromine atoms in an ion.<sup>[4]</sup>

The following sections will delve into the specific fragmentation patterns observed for individual di-brominated pyridine isomers, highlighting the subtle yet significant differences that enable their differentiation.

## Comparative Fragmentation Analysis of Di-brominated Pyridine Isomers

The substitution pattern of the bromine atoms on the pyridine ring directly influences the relative abundance of key fragment ions. While a comprehensive set of directly comparable, high-resolution mass spectra for all isomers is not readily available in the public domain, we can synthesize information from available data and established fragmentation principles to construct a comparative analysis.

### 3,5-Dibromopyridine

The mass spectrum of 3,5-dibromopyridine is available in the NIST WebBook.<sup>[5]</sup> Key features of its fragmentation are:

- **Molecular Ion ( $M^{\bullet+}$ ):** A prominent molecular ion peak cluster is observed at  $m/z$  235, 237, and 239, corresponding to the different isotopic combinations of the two bromine atoms.
- **Loss of  $Br^{\bullet}$ :** A significant fragment is observed at  $m/z$  156 and 158, corresponding to the loss of a bromine radical from the molecular ion.
- **Loss of  $HBr$ :** The loss of  $HBr$  from the molecular ion to yield a fragment at  $m/z$  155 and 157 is also a notable pathway.
- **Pyridine Ring Fragmentation:** Subsequent fragmentation of the  $[M-Br]^+$  and  $[M-HBr]^{\bullet+}$  ions leads to smaller fragments, including the pyridyl cation at  $m/z$  78 and fragments resulting from the loss of  $HCN$ .

### 2,5-Dibromopyridine

- **Molecular Ion ( $M^{\bullet+}$ ):** Similar to the 3,5-isomer, a strong molecular ion cluster at  $m/z$  235, 237, and 239 is expected.

- **Loss of Br•:** The loss of a bromine radical is a major fragmentation pathway, leading to ions at  $m/z$  156 and 158.
- **Ring Cleavage:** The position of the bromine atoms influences the subsequent fragmentation of the pyridine ring.

## Other Isomers (2,3-, 2,4-, 2,6-, and 3,4-dibromopyridine)

While detailed, publicly available spectra for these isomers are more limited, we can predict their fragmentation based on general principles. The relative intensities of the  $[M-Br]^+$  and  $[M-HBr]^+$  ions are expected to vary depending on the isomer. For instance, isomers with a bromine atom at the 2- or 4-position may exhibit different ring cleavage patterns compared to those with bromine atoms at the 3- and 5-positions due to the differing electronic effects on the pyridine ring.

The following table summarizes the expected key ions for the di-brominated pyridine isomers. Please note that the relative abundances can vary depending on the instrument and analytical conditions.

Isomer	Molecular Formula	Molecular Weight	Key Fragment Ions (m/z)	Predicted Major Fragmentation Pathways
2,3-Dibromopyridine	C <sub>5</sub> H <sub>3</sub> Br <sub>2</sub> N	236.89	235/237/239, 156/158, 155/157, 77	[M] <sup>•+</sup> , [M-Br] <sup>+</sup> , [M-HBr] <sup>•+</sup> , [C <sub>5</sub> H <sub>3</sub> N] <sup>•+</sup>
2,4-Dibromopyridine	C <sub>5</sub> H <sub>3</sub> Br <sub>2</sub> N	236.89	235/237/239, 156/158, 155/157, 77	[M] <sup>•+</sup> , [M-Br] <sup>+</sup> , [M-HBr] <sup>•+</sup> , [C <sub>5</sub> H <sub>3</sub> N] <sup>•+</sup>
2,5-Dibromopyridine	C <sub>5</sub> H <sub>3</sub> Br <sub>2</sub> N	236.89	235/237/239, 156/158, 155/157, 77	[M] <sup>•+</sup> , [M-Br] <sup>+</sup> , [M-HBr] <sup>•+</sup> , [C <sub>5</sub> H <sub>3</sub> N] <sup>•+</sup>
2,6-Dibromopyridine	C <sub>5</sub> H <sub>3</sub> Br <sub>2</sub> N	236.89	235/237/239, 156/158, 155/157, 77	[M] <sup>•+</sup> , [M-Br] <sup>+</sup> , [M-HBr] <sup>•+</sup> , [C <sub>5</sub> H <sub>3</sub> N] <sup>•+</sup>
3,4-Dibromopyridine	C <sub>5</sub> H <sub>3</sub> Br <sub>2</sub> N	236.89	235/237/239, 156/158, 155/157, 77	[M] <sup>•+</sup> , [M-Br] <sup>+</sup> , [M-HBr] <sup>•+</sup> , [C <sub>5</sub> H <sub>3</sub> N] <sup>•+</sup>
3,5-Dibromopyridine	C <sub>5</sub> H <sub>3</sub> Br <sub>2</sub> N	236.89	235/237/29, 156/158, 155/157, 78, 51	[M] <sup>•+</sup> , [M-Br] <sup>+</sup> , [M-HBr] <sup>•+</sup> , [C <sub>5</sub> H <sub>4</sub> N] <sup>+</sup> , [C <sub>4</sub> H <sub>3</sub> ] <sup>+</sup>

## Proposed Fragmentation Mechanisms

The differentiation of di-brominated pyridine isomers by mass spectrometry hinges on the subtle differences in their fragmentation pathways. Below, we propose fragmentation mechanisms for a representative isomer, 3,5-dibromopyridine, based on established principles of mass spectrometry.

## Proposed Fragmentation Pathway of 3,5-Dibromopyridine

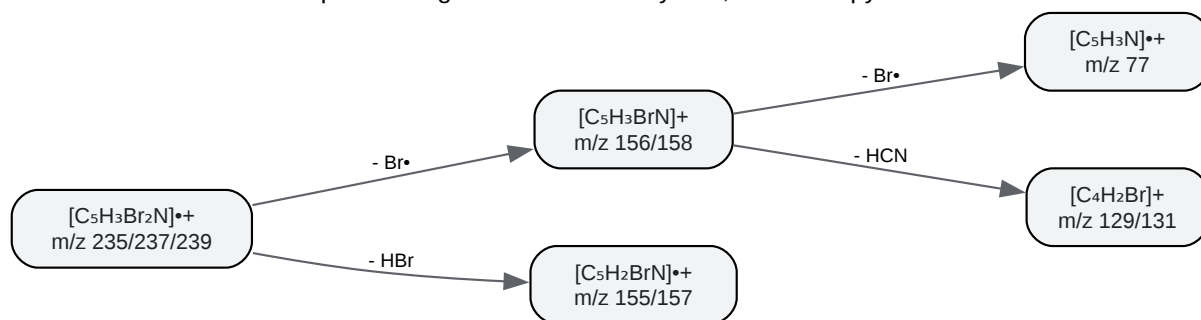

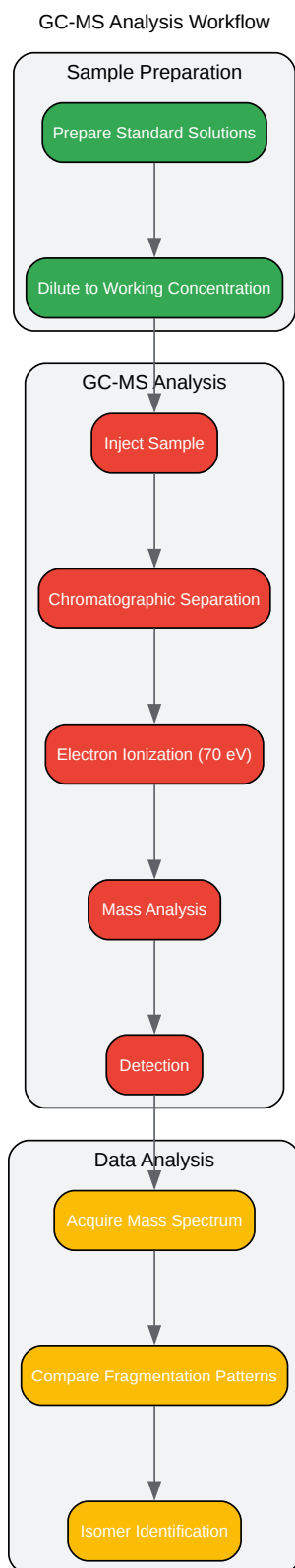

[Click to download full resolution via product page](#)

### Need Custom Synthesis?

BenchChem offers custom synthesis for rare earth carbides and specific isotopic labeling.

Email: [info@benchchem.com](mailto:info@benchchem.com) or [Request Quote Online](#).

## Sources

- [1. thiele.ruc.dk \[thiele.ruc.dk\]](#)
- [2. researchgate.net \[researchgate.net\]](#)
- [3. Pyridine, 2-bromo- \[webbook.nist.gov\]](#)
- [4. scribd.com \[scribd.com\]](#)
- [5. 3,5-Dibromopyridine \[webbook.nist.gov\]](#)
- To cite this document: BenchChem. [A Comparative Guide to the Mass Spectrometry Fragmentation Patterns of Di-brominated Pyridines]. BenchChem, [2026]. [Online PDF]. Available at: [<https://www.benchchem.com/product/b13116241/docs#a-comparative-guide-to-the-mass-spectrometry-fragmentation-patterns-of-di-brominated-pyridines>]

---

### Disclaimer & Data Validity:

The information provided in this document is for Research Use Only (RUO) and is strictly not intended for diagnostic or therapeutic procedures. While BenchChem strives to provide accurate protocols, we make no warranties, express or implied, regarding the fitness of this product for every specific experimental setup.

**Technical Support:** The protocols provided are for reference purposes. Unsure if this reagent suits your experiment?

**Need Industrial/Bulk Grade?** [Request Custom Synthesis Quote](#)

# BenchChem

Our mission is to be the trusted global source of essential and advanced chemicals, empowering scientists and researchers to drive progress in science and industry.

## Contact

Address: 3281 E Guasti Rd

Ontario, CA 91761, United States

Phone: (601) 213-4426

Email: [info@benchchem.com](mailto:info@benchchem.com)

[Contact our Ph.D. Support Team for a compatibility check](#)