

elemental analysis data for 4-ethynylbenzoyl chloride confirmation

Author: BenchChem Technical Support Team. **Date:** April 2026

Compound of Interest

Compound Name: 4-ethynylbenzoyl Chloride

CAS No.: 62480-31-3

Cat. No.: B1311383

[Get Quote](#)

An in-depth technical analysis for researchers and drug development professionals evaluating bifunctional cross-linkers, focusing on the mechanistic advantages of **4-ethynylbenzoyl chloride** (4-EBC) and the critical role of elemental analysis in quality control.

Executive Summary: The Case for 4-Ethynylbenzoyl Chloride

In the design of antibody-drug conjugates (ADCs), functionalized polymers, and targeted therapeutics, the choice of bifunctional building blocks dictates both synthetic efficiency and downstream purity[1]. **4-Ethynylbenzoyl chloride** (4-EBC) provides a distinct mechanistic advantage over traditional precursors by combining a highly reactive acyl chloride (for rapid amidation/esterification) with a terminal alkyne (for orthogonal CuAAC "click" bioconjugation). However, the extreme reactivity of the acyl chloride makes it susceptible to hydrolytic degradation. This guide compares 4-EBC against common alternatives and establishes a self-validating Elemental Analysis (EA) framework to confirm structural integrity prior to deployment.

Mechanistic Advantage: 4-EBC vs. Alternatives

When introducing an alkyne moiety to a target amine or hydroxyl group, researchers typically choose between direct acylation and coupling-reagent-mediated pathways.

- **Alternative 1: 4-Ethynylbenzoic Acid (4-EBA):** Utilizing the free acid requires stoichiometric coupling agents (e.g., EDC/NHS, HATU). This pathway generates urea byproducts (e.g., from EDC) that are notoriously difficult to clear from polar reaction mixtures, often requiring tedious reverse-phase chromatography.
- **Alternative 2: 4-Pentenoyl Chloride:** While this alternative also utilizes direct acylation, it relies on a terminal alkene rather than an alkyne. Alkenes lack the absolute bio-orthogonality of alkynes, limiting their utility in complex biological matrices where thiol-ene side reactions can occur.
- **The 4-EBC Advantage:** 4-EBC bypasses coupling agents entirely. The highly electrophilic carbonyl carbon undergoes direct nucleophilic attack by amines, generating the desired conjugate and volatile/neutralizable HCl gas as the sole byproduct.

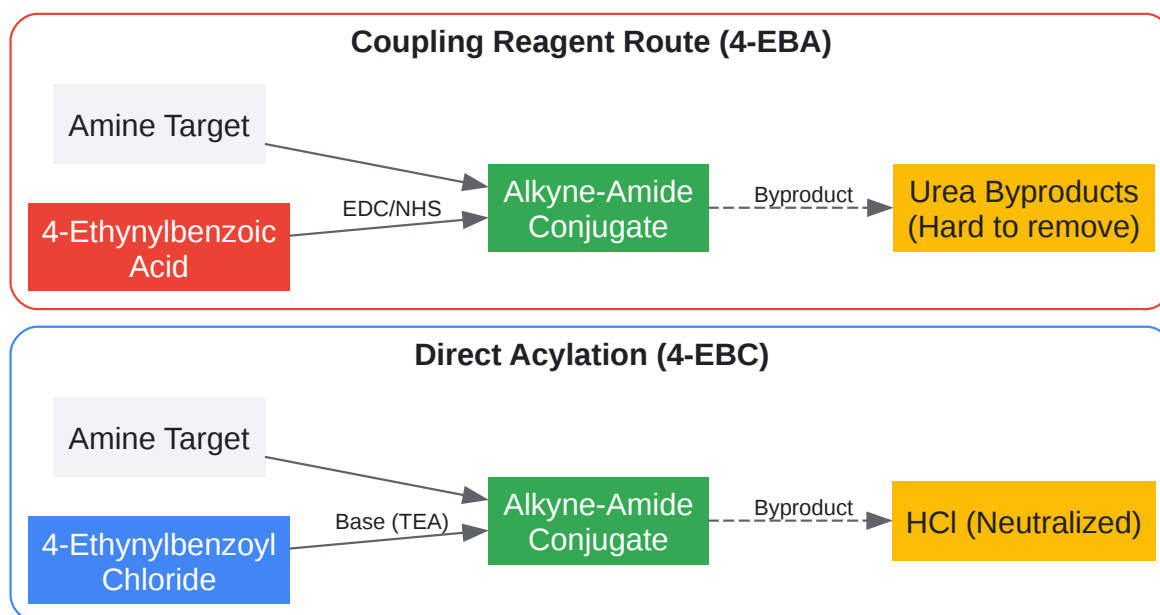

[Click to download full resolution via product page](#)

Workflow comparison: 4-EBC direct acylation vs. 4-EBA coupling reagent methodology.

Purity Confirmation: The Causality of Elemental Analysis

The primary failure mode when using 4-EBC is hydrolysis. Exposure to atmospheric moisture rapidly converts 4-EBC back into 4-EBA. If a hydrolyzed batch is used in a synthesis, the unreactive 4-EBA acts as a dead-end impurity, severely depressing yields.

While NMR spectroscopy can detect gross impurities, it struggles to precisely quantify trace inorganic salts or subtle ratios of structurally identical aromatic rings. Elemental Analysis (EA) via high-temperature combustion is the gold standard because it provides absolute mass fractions of Carbon, Hydrogen, Nitrogen, and Chlorine[2].

The Causality of the Hydrolysis Shift: When 4-EBC (C₉H₅ClO) hydrolyzes to 4-EBA (C₉H₆O₂), the mass fraction of Carbon shifts drastically upward (+8.29%), and Chlorine drops to zero (-21.54%). Because modern CHNS elemental analyzers possess a precision of ±0.3%[3], even a 3% hydrolytic degradation will trigger a detectable deviation in the carbon and chlorine readouts, making EA a perfectly self-validating quality control system.

Quantitative Comparison of Elemental Analysis Data

Compound State	Molecular Formula	% Carbon (C)	% Hydrogen (H)	% Chlorine (Cl)	% Oxygen (O)
4-EBC (Theoretical)	C ₉ H ₅ ClO	65.68%	3.06%	21.54%	9.72%
4-EBA (Hydrolyzed Impurity)	C ₉ H ₆ O ₂	73.97%	4.14%	0.00%	21.89%
4-EBC (Experimental Target)	High-Purity Batch	65.50 ± 0.3%	3.10 ± 0.3%	21.45 ± 0.3%	N/A

Experimental Protocols (Self-Validating Systems)

Protocol A: High-Efficiency Amidation using 4-EBC

This protocol utilizes Triethylamine (TEA) to drive the reaction forward. The causality behind using TEA is twofold: it acts as a nucleophilic catalyst and scavenges the generated HCl, preventing the protonation of the target amine which would otherwise halt the reaction.

- Preparation: Dissolve 1.0 eq of the target primary amine and 2.5 eq of anhydrous TEA in dry Dichloromethane (DCM) under an inert argon atmosphere.
- Acylation: Cool the reaction flask to 0°C using an ice bath. Causality: The acylation is highly exothermic; cooling suppresses side reactions such as alkyne homocoupling or solvent boiling. Dropwise, add 1.1 eq of 4-EBC dissolved in DCM.
- Propagation: Remove the ice bath and allow the reaction to stir at room temperature for 2 hours.
- Validation Checkpoint: Perform Thin-Layer Chromatography (TLC). The complete disappearance of the polar amine spot and the emergence of a less polar amide spot validates reaction completion.
- Workup: Wash the organic layer with 1M HCl (to remove excess TEA), followed by saturated NaHCO₃ and brine. Dry over Na₂SO₄ and concentrate in vacuo.

Protocol B: CHN/Cl Elemental Analysis via Combustion

To confirm the purity of 4-EBC prior to synthesis, CHN/Cl analysis is performed using the classical Pregl-Dumas method integrated with a selective halogen detector[3].

- Calibration Validation: Run a known analytical standard (e.g., 4-chlorobenzoic acid) through the analyzer. Self-Validating System: If the instrument's readout deviates by >0.3% from the theoretical values of the standard, recalibrate the Thermal Conductivity Detector (TCD) before testing the 4-EBC sample.
- Sample Encapsulation: Weigh 2-3 mg of 4-EBC into a high-purity tin capsule and crimp it shut[4]. Causality: Tin is specifically chosen because its rapid oxidation during combustion creates a localized thermal spike (>1700°C), ensuring the complete cleavage of robust C-Cl bonds[4].

- High-Temperature Combustion: Drop the capsule into the combustion furnace maintained at 1000°C in an oxygen-rich environment. The sample breaks down into CO₂, H₂O, N₂, and HCl gas[3].
- Gas Separation & Reduction: Sweep the combustion gases with an inert Helium carrier gas over a heated copper bed (600°C) to remove unreacted oxygen[3].
- Detection: Route the gases through a TCD to quantify C, H, and N[4]. Simultaneously, route the halogen stream to a micro-coulometric titration cell or a CNSX analyzer to precisely quantify the Chlorine content[2].

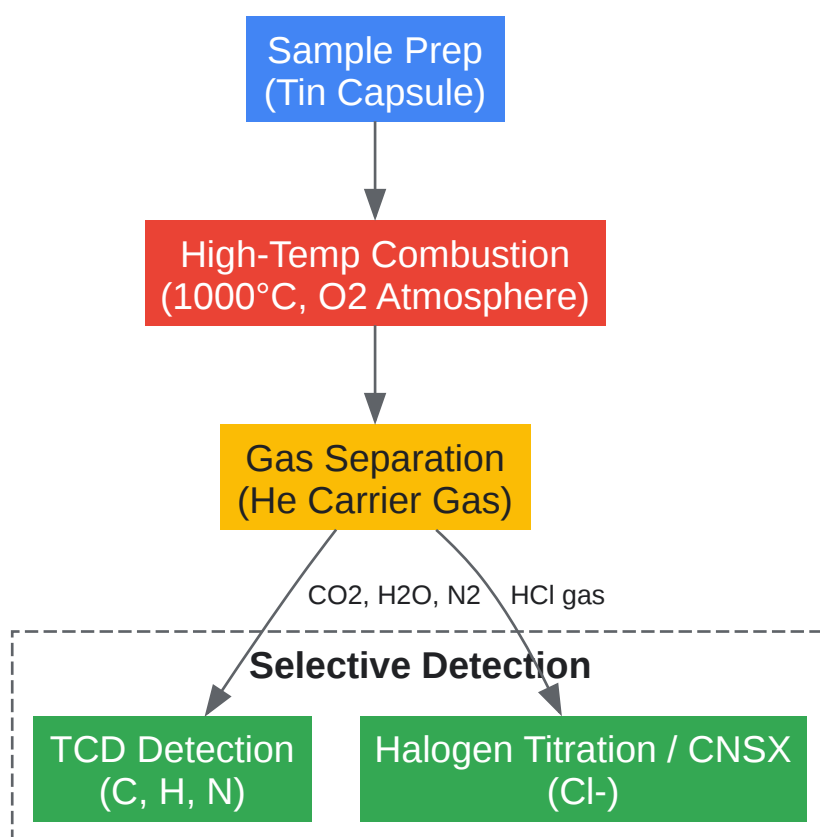

[Click to download full resolution via product page](#)

Elemental analysis workflow for simultaneous CHN and Chlorine detection.

Need Custom Synthesis?

BenchChem offers custom synthesis for rare earth carbides and specific isotopic labeling.

Email: info@benchchem.com or [Request Quote Online](#).

Sources

- [1. benicewiczgroup.com \[benicewiczgroup.com\]](https://www.benicewiczgroup.com)
- [2. C/N/S/X – Carbon, Nitrogen, Sulfur and Chlorine Analyzer - Analytik Jena \[analytik-jena.com\]](https://www.analytik-jena.com)
- [3. azom.com \[azom.com\]](https://www.azom.com)
- [4. MICROANALYSIS - Elemental Analysis Method for CHN via CHN/O/S Elemental Analyzer CHN440 \[answers.uillinois.edu\]](https://answers.uillinois.edu)
- To cite this document: BenchChem. [elemental analysis data for 4-ethynylbenzoyl chloride confirmation]. BenchChem, [2026]. [Online PDF]. Available at: [\[https://www.benchchem.com/product/b1311383/docs#elemental-analysis-data-for-4-ethynylbenzoyl-chloride-confirmation\]](https://www.benchchem.com/product/b1311383/docs#elemental-analysis-data-for-4-ethynylbenzoyl-chloride-confirmation)

Disclaimer & Data Validity:

The information provided in this document is for Research Use Only (RUO) and is strictly not intended for diagnostic or therapeutic procedures. While BenchChem strives to provide accurate protocols, we make no warranties, express or implied, regarding the fitness of this product for every specific experimental setup.

Technical Support: The protocols provided are for reference purposes. Unsure if this reagent suits your experiment?

Need Industrial/Bulk Grade? [Request Custom Synthesis Quote](#)

BenchChem

Our mission is to be the trusted global source of essential and advanced chemicals, empowering scientists and researchers to drive progress in science and industry.

Contact

Address: 3281 E Guasti Rd

Ontario, CA 91761, United States

Phone: (601) 213-4426

Email: info@benchchem.com

Contact our Ph.D. Support Team for a compatibility check