

# 4-Methoxy-1-naphthoyl Chloride chemical properties

**Author:** BenchChem Technical Support Team. **Date:** May 2026

## Compound of Interest

Compound Name: 4-Methoxy-1-naphthoyl Chloride

CAS No.: 70696-57-0

Cat. No.: B131840

[Get Quote](#)

An In-depth Technical Guide to **4-Methoxy-1-naphthoyl Chloride** for Advanced Research

## Authored by a Senior Application Scientist

This guide provides an in-depth exploration of **4-Methoxy-1-naphthoyl Chloride** (CAS No. 70696-57-0), a pivotal reagent in organic synthesis and medicinal chemistry. We will move beyond a simple recitation of facts to a functional understanding of its properties, synthesis, reactivity, and application, grounded in mechanistic principles and practical laboratory considerations. This document is designed for researchers and drug development professionals who require a comprehensive understanding of this versatile chemical intermediate.

## Core Physicochemical & Structural Characteristics

**4-Methoxy-1-naphthoyl Chloride** is a derivative of naphthalene, featuring a methoxy group at the 4-position and an acyl chloride at the 1-position. This substitution pattern imparts specific reactivity and electronic properties that are highly valuable in synthetic applications. The electron-donating nature of the methoxy group influences the reactivity of both the naphthalene ring and the acyl chloride function.

A summary of its fundamental properties is presented below:

Property	Value	Source(s)
CAS Number	70696-57-0	[1][2]
Molecular Formula	C <sub>12</sub> H <sub>9</sub> ClO <sub>2</sub>	[1][2][3]
Molecular Weight	220.65 g/mol	[1][2][3]
Appearance	Brown Solid	[2]
SMILES	<chem>COC1=CC=C(C2=CC=CC=C21)C(=O)Cl</chem>	[1]

## Synthesis of 4-Methoxy-1-naphthoyl Chloride: A Mechanistic Approach

The most direct and common laboratory synthesis of **4-Methoxy-1-naphthoyl Chloride** involves the chlorination of its corresponding carboxylic acid, 4-methoxy-1-naphthoic acid. Thionyl chloride (SOCl<sub>2</sub>) is the reagent of choice for this transformation due to its high efficiency and the convenient removal of byproducts.[4][5]

The rationale for using thionyl chloride over other chlorinating agents like phosphorus chlorides (PCl<sub>3</sub>, PCl<sub>5</sub>) often lies in the simplicity of the workup.[6] The reaction between the carboxylic acid and thionyl chloride produces the desired acyl chloride along with sulfur dioxide (SO<sub>2</sub>) and hydrogen chloride (HCl) as gaseous byproducts, which can be easily removed, driving the reaction to completion according to Le Châtelier's principle.[4][7]

### Reaction Mechanism: Carboxylic Acid to Acyl Chloride

The conversion proceeds via a nucleophilic acyl substitution mechanism where the carboxylic acid oxygen attacks the electrophilic sulfur atom of thionyl chloride. This is followed by a sequence of steps resulting in the formation of the acyl chloride.

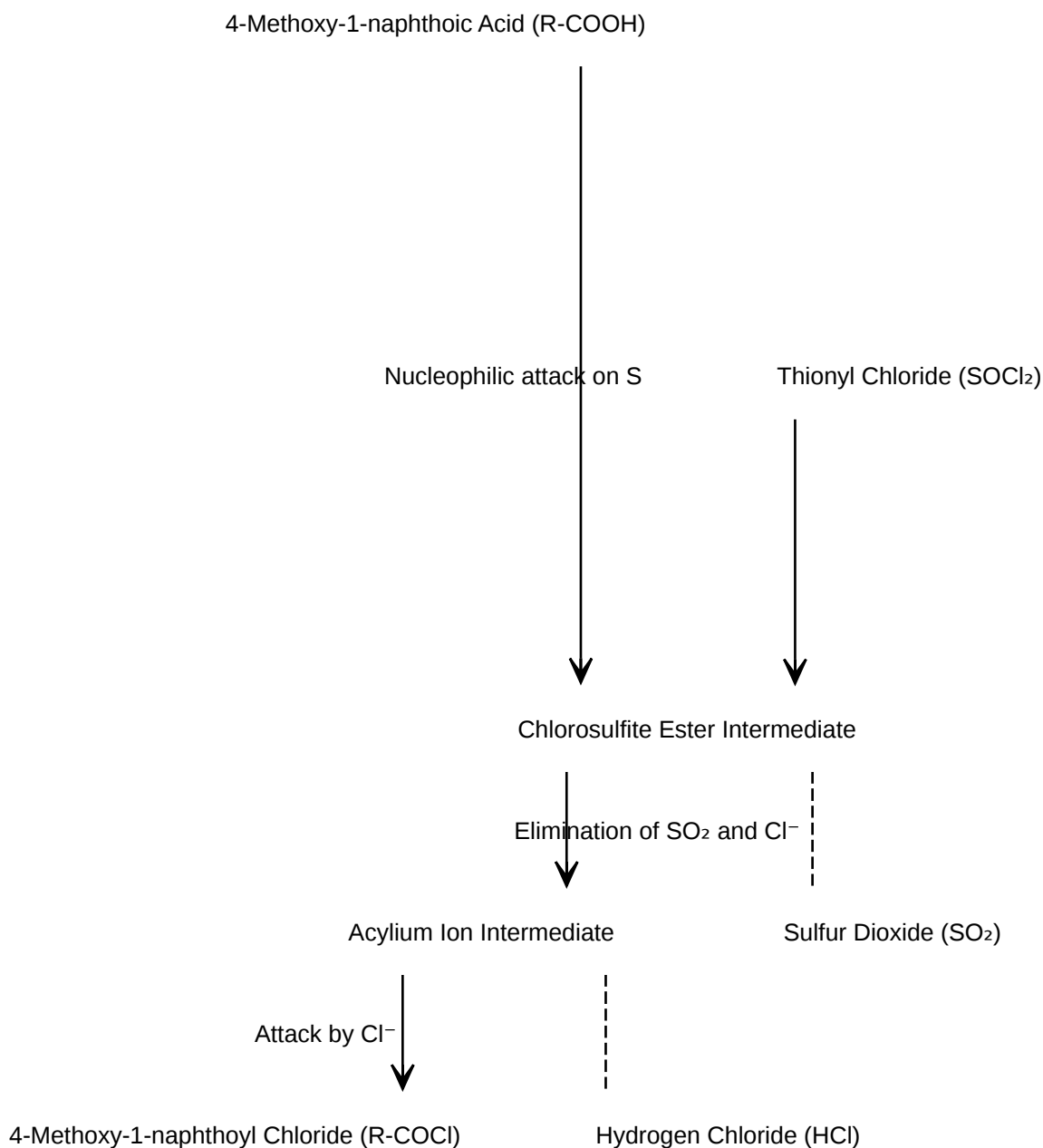

[Click to download full resolution via product page](#)

Caption: Mechanism for the conversion of a carboxylic acid to an acyl chloride using thionyl chloride.

## Validated Laboratory Protocol for Synthesis

This protocol describes the synthesis of **4-Methoxy-1-naphthoyl Chloride** from 4-methoxy-1-naphthoic acid.

#### Materials:

- 4-methoxy-1-naphthoic acid
- Thionyl chloride (SOCl<sub>2</sub>), neat<sup>[5]</sup>
- Anhydrous Toluene (optional, as a solvent or for azeotropic removal of excess SOCl<sub>2</sub>)
- Round-bottom flask with reflux condenser and gas trap (to neutralize HCl and SO<sub>2</sub>)
- Magnetic stirrer and heating mantle

#### Procedure:

- **Setup:** Assemble a flame-dried round-bottom flask equipped with a magnetic stir bar, a reflux condenser, and a gas outlet connected to a trap containing aqueous sodium hydroxide. The entire apparatus must be protected from atmospheric moisture.
- **Reaction:** Place 4-methoxy-1-naphthoic acid (1.0 eq) into the flask. Add an excess of thionyl chloride (typically 2-5 eq), either neat or with a small amount of an inert solvent like toluene.<sup>[5]</sup>
- **Heating:** Gently heat the mixture to reflux (the boiling point of thionyl chloride is ~76 °C) with stirring. The reaction progress can be monitored by the cessation of HCl and SO<sub>2</sub> gas evolution. The reaction is typically complete within 1-3 hours.
- **Workup:** After cooling the reaction mixture to room temperature, remove the excess thionyl chloride under reduced pressure. To ensure complete removal, anhydrous toluene can be added and subsequently evaporated (azeotropic removal).<sup>[8]</sup>
- **Isolation:** The resulting crude **4-Methoxy-1-naphthoyl Chloride** is often of sufficient purity for subsequent reactions. If higher purity is required, distillation under high vacuum can be performed, though this is often unnecessary and can lead to decomposition if not carefully controlled.

## Spectroscopic Profile: An Analytical Perspective

While a dedicated public spectrum for **4-Methoxy-1-naphthoyl Chloride** is not readily available, its structure can be confidently confirmed using standard spectroscopic methods. The expected spectral characteristics are outlined below, based on the analysis of structurally similar compounds and established principles.<sup>[9][10][11]</sup>

Technique	Expected Characteristics
<sup>1</sup> H NMR	<ul style="list-style-type: none"><li>- Methoxy Protons (-OCH<sub>3</sub>): A sharp singlet at approximately <math>\delta</math> 4.0 ppm.</li><li>- Naphthalene Protons: A series of complex multiplets in the aromatic region (<math>\delta</math> 7.0-8.5 ppm), with distinct coupling patterns characteristic of the substituted naphthalene ring system.</li></ul>
<sup>13</sup> C NMR	<ul style="list-style-type: none"><li>- Carbonyl Carbon (-COCl): A signal in the downfield region, typically <math>\delta</math> 165-170 ppm.</li><li>- Methoxy Carbon (-OCH<sub>3</sub>): A signal around <math>\delta</math> 55-60 ppm.<sup>[11]</sup></li><li>- Aromatic Carbons: Multiple signals between <math>\delta</math> 100-160 ppm.</li></ul>
IR Spectroscopy	<ul style="list-style-type: none"><li>- C=O Stretch (Acyl Chloride): A strong, sharp absorption band in the region of 1780-1815 cm<sup>-1</sup>. This higher frequency compared to other carbonyl compounds is a hallmark of acyl chlorides.</li><li>- C-O Stretch (Aryl Ether): A strong band around 1250 cm<sup>-1</sup>.</li><li>- Aromatic C=C Stretch: Peaks in the 1500-1600 cm<sup>-1</sup> region.</li></ul>
Mass Spectrometry	<ul style="list-style-type: none"><li>- Molecular Ion (M<sup>+</sup>): A peak corresponding to the molecular weight (<math>m/z \approx 220.65</math>). The isotopic pattern for one chlorine atom (<sup>35</sup>Cl/<sup>37</sup>Cl in a ~3:1 ratio) will be observable at M<sup>+</sup> and M+2.</li><li>- Major Fragment: Loss of the chlorine atom to form the stable 4-methoxy-1-naphthoyl acylium ion (<math>m/z \approx 185</math>).</li></ul>

# Chemical Reactivity & Applications in Drug Development

As an acyl chloride, **4-Methoxy-1-naphthoyl Chloride** is a potent electrophile, primarily used as an acylating agent in nucleophilic acyl substitution reactions.[12] Its utility is central to the construction of more complex molecules, particularly in the synthesis of pharmacologically active compounds.

## A. Friedel-Crafts Acylation

This reaction is a cornerstone of C-C bond formation, attaching the 4-methoxy-1-naphthoyl moiety to an aromatic ring.[13] The reaction requires a Lewis acid catalyst, such as aluminum chloride ( $\text{AlCl}_3$ ), to activate the acyl chloride.[14]

Mechanism: The Lewis acid coordinates to the chlorine atom, polarizing the C-Cl bond and facilitating the formation of a highly electrophilic acylium ion, which is then attacked by the nucleophilic aromatic ring.[14][15]

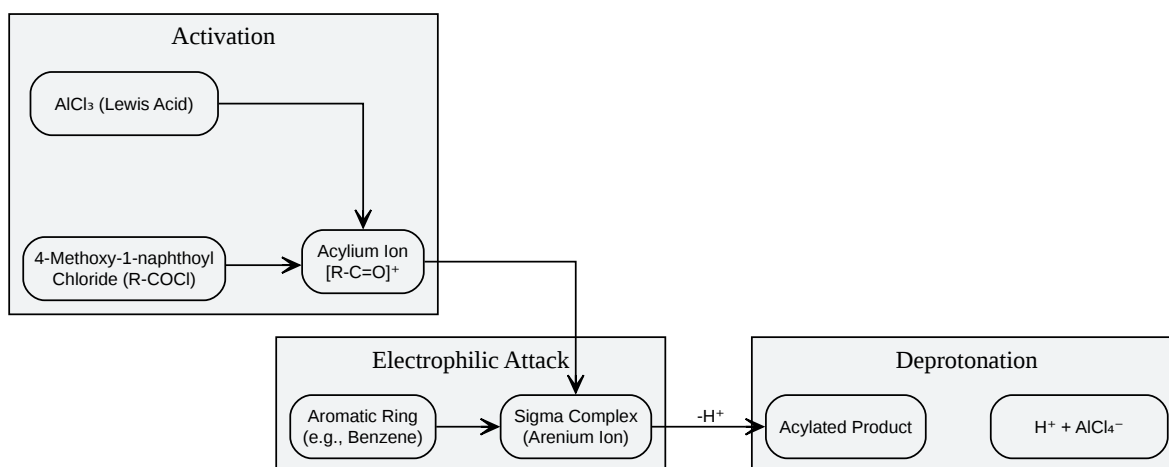

[Click to download full resolution via product page](#)

Caption: Workflow for Friedel-Crafts Acylation.

## B. Synthesis of Amides and Esters

The reaction of **4-Methoxy-1-naphthoyl Chloride** with primary or secondary amines or alcohols provides a direct route to the corresponding amides and esters. These functional groups are ubiquitous in pharmaceuticals, contributing to molecular stability and the ability to form hydrogen bonds with biological targets.

Application in Drug Discovery: The 4-methoxy-1-naphthoyl scaffold is of significant interest in medicinal chemistry.

- **Cannabinoid Receptor Ligands:** Studies have shown that incorporating a 4-methoxy-1-naphthoyl group into indole-based structures can enhance binding affinity for both CB1 and CB2 cannabinoid receptors, which are targets for pain, inflammation, and other neurological disorders.[\[16\]](#)
- **Anticancer Agents:** The related 4-benzoyl imidazole scaffold has been explored for its ability to inhibit tubulin polymerization, a validated anticancer strategy.[\[17\]](#) The structural and electronic properties of the 4-methoxy-1-naphthoyl group make it an attractive component for similar drug design efforts.
- **Gastrointestinal Treatments:** It has been specifically noted for its use in preparing isoindole derivatives intended for the treatment of gastrointestinal diseases.[\[2\]](#)

## Representative Protocol: Amide Synthesis

This protocol details the acylation of a primary amine with **4-Methoxy-1-naphthoyl Chloride**.

Materials:

- **4-Methoxy-1-naphthoyl Chloride**
- Primary or secondary amine (1.0 eq)
- Anhydrous aprotic solvent (e.g., Dichloromethane (DCM) or Tetrahydrofuran (THF))
- Tertiary amine base (e.g., Triethylamine or Pyridine, 1.1-1.5 eq)

- Stirring plate, ice bath, and nitrogen atmosphere setup

#### Procedure:

- **Dissolution:** Dissolve the amine (1.0 eq) and the tertiary amine base (e.g., triethylamine) in an anhydrous solvent under a nitrogen atmosphere.
- **Cooling:** Cool the solution to 0 °C in an ice bath. This is critical to control the exothermicity of the reaction.
- **Addition:** Dissolve **4-Methoxy-1-naphthoyl Chloride** (1.0-1.1 eq) in a minimal amount of the same anhydrous solvent and add it dropwise to the cooled amine solution with vigorous stirring over 15-30 minutes.
- **Reaction:** After the addition is complete, allow the reaction mixture to warm to room temperature and continue stirring for 1-4 hours. Monitor the reaction's progress by Thin Layer Chromatography (TLC).
- **Quenching & Extraction:** Upon completion, quench the reaction by adding water. Transfer the mixture to a separatory funnel. If using a water-miscible solvent, dilute with a water-immiscible solvent like ethyl acetate.
- **Washing:** Wash the organic layer sequentially with a weak acid (e.g., 1 M HCl) to remove excess amine, a weak base (e.g., saturated NaHCO<sub>3</sub> solution) to remove any unreacted starting material and HCl, and finally with brine.
- **Drying and Concentration:** Dry the organic layer over an anhydrous drying agent (e.g., Na<sub>2</sub>SO<sub>4</sub> or MgSO<sub>4</sub>), filter, and concentrate the solvent under reduced pressure using a rotary evaporator to yield the crude amide product, which can then be purified by recrystallization or column chromatography.

## Safety, Handling, and Storage

**4-Methoxy-1-naphthoyl Chloride** is a reactive and corrosive chemical that requires careful handling. Adherence to strict safety protocols is mandatory.

- Hazards:

- Corrosive: Causes severe skin burns and eye damage upon contact.[18][19]
- Moisture Sensitive: Reacts violently with water and other protic solvents to release corrosive hydrogen chloride (HCl) gas.
- Respiratory Irritant: Inhalation of dust or fumes can cause severe irritation to the respiratory tract.[18][20]
- Handling:
  - Always handle inside a certified chemical fume hood.[21]
  - Wear appropriate Personal Protective Equipment (PPE), including chemical-resistant gloves (e.g., nitrile), a lab coat, and chemical safety goggles with a face shield.[18][22]
  - Avoid inhalation of dust and vapors. Do not allow the substance to come into contact with skin or eyes.[21]
  - Use only spark-proof tools and equipment.
- Storage:
  - Store in a tightly sealed container to prevent contact with moisture.[19][21]
  - The use of a desiccator or storage under an inert atmosphere (e.g., nitrogen or argon) is highly recommended.[18][19]
  - Store in a cool, dry, and well-ventilated area away from incompatible substances such as water, alcohols, amines, strong bases, and oxidizing agents.[18][19]

## Conclusion

**4-Methoxy-1-naphthoyl Chloride** is a high-value synthetic intermediate whose utility is rooted in its predictable and potent reactivity as an acylating agent. A thorough understanding of its synthesis, handling requirements, and reaction mechanisms—particularly in Friedel-Crafts acylation and the formation of amides and esters—enables researchers to effectively leverage this compound in the design and synthesis of novel molecules. Its demonstrated role in the

development of bioactive compounds underscores its continued importance in the fields of medicinal chemistry and drug discovery.

## References

- BenchChem. (n.d.). Application Notes and Protocols: Synthesis of 4-Methoxybenzoic Acid Amides from Acid Chloride.
- American Chemical Society. (2026, January 12). Enantioselective [4 + 2] Annulation Reaction of C1-Ammonium Enolate and Azadiene for 3,4-Dihydroquinolinones Synthesis.
- National Center for Biotechnology Information. (n.d.). 4-Methoxy-1-naphthol. PubChem. Retrieved from [\[Link\]](#)
- Angene Chemical. (n.d.). **4-Methoxy-1-naphthoyl Chloride** (CAS# 70696-57-0). Retrieved from [\[Link\]](#)
- The Organic Chemistry Tutor. (2016, December 28). Friedel Crafts Alkylation and Acylation Reaction Mechanism. YouTube. [\[Link\]](#)
- Master Organic Chemistry. (2011, December 3). Thionyl Chloride (SOCl<sub>2</sub>) And Conversion of Carboxylic Acids to Acid Halides. Retrieved from [\[Link\]](#)
- National Center for Biotechnology Information. (n.d.). Applications of Friedel–Crafts reactions in total synthesis of natural products. PMC. Retrieved from [\[Link\]](#)
- ResearchGate. (2017, September 26). Synthesis of 5-Methoxy-1, 2, 3, 4- Tetrahydro -2- Naphthoic Acid. [\[Link\]](#)
- Cole-Parmer. (n.d.). Material Safety Data Sheet - 1-Naphthoyl chloride, 99%. Retrieved from [\[Link\]](#)
- OC-Lab.com. (2020, October 15). Friedel Crafts Acylation Experiment Part 1, Prelab. YouTube. [\[Link\]](#)
- Chemguide. (n.d.). Converting carboxylic acids into acyl chlorides (acid chlorides). Retrieved from [\[Link\]](#)
- Organic Syntheses. (n.d.). α-NAPHTHOIC ACID. Retrieved from [\[Link\]](#)

- Huffman, J. W., et al. (n.d.). Synthesis and Pharmacology of 1-Alkyl-3-(1-naphthoyl)indoles: Steric and Electronic Effects of 4- and 6-Substituents. PubMed Central. Retrieved from [[Link](#)]
- Master Organic Chemistry. (2018, May 17). EAS Reactions (3) - Friedel-Crafts Acylation and Friedel-Crafts Alkylation. Retrieved from [[Link](#)]
- Bioman Explains. (2024, April 1). Carboxylic Acids to Acyl Chlorides Using Thionyl Chloride (SOCl<sub>2</sub>). YouTube. [[Link](#)]
- National Center for Biotechnology Information. (n.d.). Discovery of novel 2-aryl-4-benzoyl-imidazoles targeting the colchicines binding site in tubulin as potential anticancer agents. PMC. Retrieved from [[Link](#)]
- ResearchGate. (2019, March 6). NMR, mass spectroscopy, IR - finding compound structure?. [[Link](#)]
- Organic Chemistry Portal. (n.d.). Acid to Acid Chloride - Common Conditions. Retrieved from [[Link](#)]
- Google Patents. (n.d.). CN112661627A - Method for synthesizing 1-naphthoic acid from naphthalene and carbon dioxide.
- Ross, J., & Xiao, J. (n.d.). Friedel–Crafts acylation reactions using metal triflates in ionic liquid. University of Liverpool. [[Link](#)]
- The Royal Society of Chemistry. (2015). Ligand-free Pd Catalyzed Cross-coupling Reactions in Aqueous Hydrotropic Medium. Retrieved from [[Link](#)]
- Reddit. (2025, March 31). Synthesis of Acyl Chlorides with Thionyl Chloride. r/Chempros. [[Link](#)]
- ChemSynthesis. (2025, May 20). 4-hydroxy-5-methoxy-1-phenyl-2-naphthoic acid. Retrieved from [[Link](#)]
- Google Patents. (n.d.). CN102838525A - Synthesis method of 1-amyl-3-(1naphthoyl) indole.
- National Center for Biotechnology Information. (n.d.). 2-Methoxynaphthalene-1-carbonyl chloride. PubChem. Retrieved from [[Link](#)]

- Organic Chemistry I Review. (n.d.). Highlights of Key Reactions, Mechanisms, and Principles. [[Link](#)]
- ResearchGate. (n.d.). Methoxy <sup>13</sup>C NMR Chemical Shift as a Molecular Descriptor in the Structural Analysis of Flavonoids and Other Phenolic Compounds. [[Link](#)]
- Organic Syntheses. (n.d.). p-METHOXYPHENYLACETONITRILE. Retrieved from [[Link](#)]
- Chemistry LibreTexts. (2025, May 27). Chapter 23.4: Common Classes of Organic Reactions. Retrieved from [[Link](#)]

### Need Custom Synthesis?

BenchChem offers custom synthesis for rare earth carbides and specific isotopic labeling.

Email: [info@benchchem.com](mailto:info@benchchem.com) or [Request Quote Online](#).

## Sources

1. [angenesci.com](https://www.angenesci.com) [[angenesci.com](https://www.angenesci.com)]
2. 4-methoxy-1-naphthoyl chloride CAS#: 70696-57-0 [[m.chemicalbook.com](https://www.m.chemicalbook.com)]
3. [scbt.com](https://www.scbt.com) [[scbt.com](https://www.scbt.com)]
4. [masterorganicchemistry.com](https://www.masterorganicchemistry.com) [[masterorganicchemistry.com](https://www.masterorganicchemistry.com)]
5. Acid to Acid Chloride - Common Conditions [[commonorganicchemistry.com](https://www.commonorganicchemistry.com)]
6. [chemguide.co.uk](https://www.chemguide.co.uk) [[chemguide.co.uk](https://www.chemguide.co.uk)]
7. [m.youtube.com](https://www.m.youtube.com) [[m.youtube.com](https://www.m.youtube.com)]
8. [reddit.com](https://www.reddit.com) [[reddit.com](https://www.reddit.com)]
9. 4-METHOXY-1-NAPHTHOL(84-85-5) 1H NMR spectrum [[chemicalbook.com](https://www.chemicalbook.com)]
10. 4-Methoxy-1-naphthaldehyde(15971-29-6) <sup>13</sup>C NMR spectrum [[chemicalbook.com](https://www.chemicalbook.com)]
11. [researchgate.net](https://www.researchgate.net) [[researchgate.net](https://www.researchgate.net)]
12. [chem.libretexts.org](https://chem.libretexts.org) [[chem.libretexts.org](https://chem.libretexts.org)]
13. Applications of Friedel–Crafts reactions in total synthesis of natural products - PMC [[pmc.ncbi.nlm.nih.gov](https://pubmed.ncbi.nlm.nih.gov)]

- [14. masterorganicchemistry.com \[masterorganicchemistry.com\]](https://www.masterorganicchemistry.com)
- [15. youtube.com \[youtube.com\]](https://www.youtube.com)
- [16. Synthesis and Pharmacology of 1-Alkyl-3-\(1-naphthoyl\)indoles: Steric and Electronic Effects of 4- and 8-Halogenated Naphthoyl Substituents - PMC \[pmc.ncbi.nlm.nih.gov\]](https://pubmed.ncbi.nlm.nih.gov/16111111/)
- [17. Discovery of novel 2-aryl-4-benzoyl-imidazoles targeting the colchicines binding site in tubulin as potential anticancer agents - PMC \[pmc.ncbi.nlm.nih.gov\]](https://pubmed.ncbi.nlm.nih.gov/16111111/)
- [18. synquestlabs.com \[synquestlabs.com\]](https://www.synquestlabs.com)
- [19. fishersci.com \[fishersci.com\]](https://www.fishersci.com)
- [20. 4-Methoxy-1-naphthol | C<sub>11</sub>H<sub>10</sub>O<sub>2</sub> | CID 66542 - PubChem \[pubchem.ncbi.nlm.nih.gov\]](https://pubchem.ncbi.nlm.nih.gov/compound/4-Methoxy-1-naphthol)
- [21. pim-resources.coleparmer.com \[pim-resources.coleparmer.com\]](https://www.pim-resources.coleparmer.com)
- [22. fishersci.com \[fishersci.com\]](https://www.fishersci.com)
- To cite this document: BenchChem. [4-Methoxy-1-naphthoyl Chloride chemical properties]. BenchChem, [2026]. [Online PDF]. Available at: [\[https://www.benchchem.com/product/b131840/docs#4-methoxy-1-naphthoyl-chloride-chemical-properties\]](https://www.benchchem.com/product/b131840/docs#4-methoxy-1-naphthoyl-chloride-chemical-properties)

---

#### Disclaimer & Data Validity:

The information provided in this document is for Research Use Only (RUO) and is strictly not intended for diagnostic or therapeutic procedures. While BenchChem strives to provide accurate protocols, we make no warranties, express or implied, regarding the fitness of this product for every specific experimental setup.

**Technical Support:** The protocols provided are for reference purposes. Unsure if this reagent suits your experiment?

**Need Industrial/Bulk Grade?** [Request Custom Synthesis Quote](#)

# BenchChem

Our mission is to be the trusted global source of essential and advanced chemicals, empowering scientists and researchers to drive progress in science and industry.

## Contact

Address: 3281 E Guasti Rd

Ontario, CA 91761, United States

Phone: (601) 213-4426

Email: [info@benchchem.com](mailto:info@benchchem.com)

[Contact our Ph.D. Support Team for a compatibility check](#)