

Technical Support Center: Synthesis of Imidazo[2,1-b]thiazol-6-ylmethanamine

Author: BenchChem Technical Support Team. **Date:** January 2026

Compound of Interest

Compound Name: *Imidazo[2,1-b]thiazol-6-ylmethanamine*

Cat. No.: *B1309308*

[Get Quote](#)

This technical support guide is designed for researchers, scientists, and professionals in drug development who are working on the synthesis of **Imidazo[2,1-b]thiazol-6-ylmethanamine**. Here, you will find troubleshooting advice, frequently asked questions (FAQs), detailed experimental protocols, and visual guides to help improve your reaction yields and overcome common challenges.

Frequently Asked Questions (FAQs) & Troubleshooting Guide

This section addresses specific issues that may arise during the synthesis of **Imidazo[2,1-b]thiazol-6-ylmethanamine** and its intermediates.

Q1: My overall yield for the synthesis is consistently low. What are the most likely causes and how can I improve it?

A1: Low yields in the synthesis of **Imidazo[2,1-b]thiazol-6-ylmethanamine** can stem from several factors throughout the multi-step process. A systematic approach to troubleshooting is recommended.^[1] Common causes include:

- **Suboptimal Reaction Conditions:** Temperature, reaction time, and reactant concentrations are critical. Small-scale trial reactions can help determine the ideal parameters without committing large amounts of starting material.

- **Purity of Reagents and Solvents:** Impurities in starting materials or solvents can lead to side reactions or incomplete conversion. Always use reagents and solvents of appropriate purity and ensure solvents are dry when necessary.
- **Atmospheric Moisture and Oxygen:** Certain steps, particularly those involving organometallic reagents or strong bases, can be sensitive to air and moisture. Employing proper inert atmosphere techniques (e.g., using nitrogen or argon) is crucial.
- **Inefficient Mixing:** In heterogeneous reactions, inadequate stirring can result in poor reaction rates and lower yields. Ensure the stirring is vigorous enough for the scale and viscosity of your reaction mixture.
- **Product Decomposition:** The desired product or intermediates may be unstable under the reaction or workup conditions. Monitoring the reaction by Thin Layer Chromatography (TLC) or Liquid Chromatography-Mass Spectrometry (LC-MS) can help detect product degradation.

Q2: I am having trouble with the first step, the synthesis of the Imidazo[2,1-b]thiazole core. What are some common issues?

A2: The formation of the Imidazo[2,1-b]thiazole ring system is a critical step. Common challenges include:

- **Low Yield of Cyclization:** This can be due to incomplete reaction or the formation of side products.
 - **Troubleshooting:**
 - **Solvent Choice:** The polarity of the solvent can significantly influence the reaction rate. Experiment with different solvents, such as ethanol, DMF, or toluene.
 - **Temperature Control:** While some reactions require heat to proceed, excessive temperatures can lead to decomposition. Optimize the reaction temperature by gradually increasing it and monitoring the progress.
 - **Catalyst:** Some variations of this synthesis may benefit from a catalyst. While classical methods may not use one, newer methodologies sometimes employ catalysts to improve yield and reaction time.

Q3: The Vilsmeier-Haack formylation to produce Imidazo[2,1-b]thiazole-6-carbaldehyde is not working well. What should I check?

A3: The Vilsmeier-Haack reaction is a key step to introduce the aldehyde functionality. If you are facing issues, consider the following:

- **Reagent Quality:** The Vilsmeier reagent (formed from phosphorus oxychloride and DMF) is sensitive to moisture. Ensure it is freshly prepared under anhydrous conditions.
- **Reaction Temperature:** The reaction is typically carried out at low temperatures (0-5 °C) during the addition of the substrate to the Vilsmeier reagent, and then gently warmed. Deviations from the optimal temperature profile can lead to side reactions.
- **Work-up Procedure:** The work-up usually involves quenching with an ice-cold aqueous solution of a base (like sodium carbonate or sodium hydroxide) to neutralize the acid and hydrolyze the intermediate. Improper pH adjustment can lead to low yields of the aldehyde.

Q4: I am struggling with the final reductive amination step to get **Imidazo[2,1-b]thiazol-6-ylmethanamine**. What can I do to improve the yield?

A4: Reductive amination can be a delicate reaction. Here are some troubleshooting tips:

- **Choice of Reducing Agent:** The choice of reducing agent is critical. Sodium borohydride (NaBH₄) and sodium triacetoxyborohydride (STAB) are commonly used. STAB is often milder and more selective for the imine intermediate, which can reduce the formation of over-reduced byproducts.
- **pH Control:** The pH of the reaction mixture is crucial for the formation of the imine intermediate. A slightly acidic pH (around 5-6) is generally optimal.
- **Amine Source:** The concentration and type of amine source (e.g., ammonia, ammonium acetate) can impact the equilibrium of imine formation. Ensure an adequate excess of the amine source is used.
- **Reaction Time and Temperature:** These parameters should be optimized. The reaction may need to be run at room temperature or slightly elevated temperatures for a sufficient duration to ensure complete conversion.

Data Presentation

Due to the limited availability of specific yield data for the direct synthesis of **Imidazo[2,1-b]thiazol-6-ylmethanamine** in the literature, the following table summarizes typical yields for key steps in the synthesis of closely related Imidazo[2,1-b]thiazole derivatives. This data can serve as a benchmark for optimizing your synthesis.

Step	Reaction	Reagents	Solvent	Temperature (°C)	Time (h)	Yield (%)	Reference
1	Imidazo[2,1-b]thiazole formation	2-Aminothiazole, α -haloketone	Ethanol	Reflux	8-24	70-85	[2]
2	Vilsmeier-Haack Formylation	Imidazo[2,1-b]thiazole, POCl ₃ , DMF	Dichloromethane	0 - RT	2-4	60-75	[2]
3	Reductive Amination	Imidazo[2,1-b]thiazole-6-carbaldehyde, Amine, Reducing Agent	Methanol / THF	RT	12-24	50-70	General knowledge

Experimental Protocols

The following are generalized experimental protocols for the key steps in the synthesis of **Imidazo[2,1-b]thiazol-6-ylmethanamine**, based on procedures for analogous compounds.

Step 1: Synthesis of the Imidazo[2,1-b]thiazole Core

A common method for constructing the Imidazo[2,1-b]thiazole core is through the condensation of 2-aminothiazole with an α -halo ketone.

Materials:

- 2-Aminothiazole
- α -Bromoacetophenone (or other suitable α -halo ketone)
- Ethanol

Procedure:

- Dissolve 2-aminothiazole (1 equivalent) and the α -bromoacetophenone (1 equivalent) in ethanol in a round-bottom flask.
- Heat the mixture to reflux and monitor the reaction progress using TLC. The reaction is typically complete within 8-24 hours.
- After completion, cool the reaction mixture to room temperature.
- The product may precipitate out of the solution. If so, collect the solid by filtration.
- If the product does not precipitate, remove the solvent under reduced pressure.
- Purify the crude product by recrystallization or column chromatography.

Step 2: Vilsmeier-Haack Formylation of Imidazo[2,1-b]thiazole

This step introduces a formyl group at the 6-position of the Imidazo[2,1-b]thiazole ring.

Materials:

- Imidazo[2,1-b]thiazole derivative from Step 1
- Phosphorus oxychloride (POCl_3)

- N,N-Dimethylformamide (DMF)
- Dichloromethane (DCM)
- Sodium carbonate solution (saturated)

Procedure:

- In a flame-dried, three-necked flask under an inert atmosphere, add anhydrous DMF to anhydrous DCM and cool the solution to 0 °C.
- Slowly add POCl₃ (3 equivalents) to the cooled DMF/DCM solution with vigorous stirring. Stir the mixture at 0 °C for 30 minutes to form the Vilsmeier reagent.
- Dissolve the Imidazo[2,1-b]thiazole derivative (1 equivalent) in anhydrous DCM and add it dropwise to the Vilsmeier reagent at 0 °C.
- Allow the reaction mixture to warm to room temperature and stir for 2-4 hours. Monitor the reaction by TLC.
- After the reaction is complete, carefully pour the mixture into a beaker containing crushed ice and a saturated solution of sodium carbonate.
- Stir vigorously until the pH is basic.
- Extract the aqueous layer with DCM (3 x).
- Combine the organic layers, dry over anhydrous sodium sulfate, filter, and concentrate under reduced pressure.
- Purify the resulting Imidazo[2,1-b]thiazole-6-carbaldehyde by column chromatography.

Step 3: Reductive Amination to Imidazo[2,1-b]thiazol-6-ylmethanamine

This final step converts the aldehyde to the desired primary amine.

Materials:

- Imidazo[2,1-b]thiazole-6-carbaldehyde from Step 2
- Ammonium acetate or another ammonia source
- Sodium triacetoxyborohydride (STAB) or Sodium borohydride (NaBH₄)
- Methanol or Tetrahydrofuran (THF)
- Acetic acid (glacial)

Procedure:

- Dissolve the Imidazo[2,1-b]thiazole-6-carbaldehyde (1 equivalent) and a large excess of ammonium acetate (e.g., 10 equivalents) in methanol.
- Add a catalytic amount of glacial acetic acid to adjust the pH to approximately 5-6.
- Stir the mixture at room temperature for 1-2 hours to allow for the formation of the imine intermediate.
- Cool the reaction mixture to 0 °C and add the reducing agent (e.g., STAB, 1.5 equivalents) portion-wise.
- Allow the reaction to warm to room temperature and stir for 12-24 hours. Monitor the reaction by TLC.
- Once the reaction is complete, quench it by the slow addition of water.
- Make the solution basic by adding a saturated solution of sodium bicarbonate.
- Extract the product with a suitable organic solvent (e.g., ethyl acetate or DCM).
- Dry the combined organic layers over anhydrous sodium sulfate, filter, and concentrate under reduced pressure.
- Purify the crude **Imidazo[2,1-b]thiazol-6-ylmethanamine** by column chromatography.

Visualizations

The following diagrams illustrate the synthetic pathway and a troubleshooting workflow to help visualize the process and decision-making.

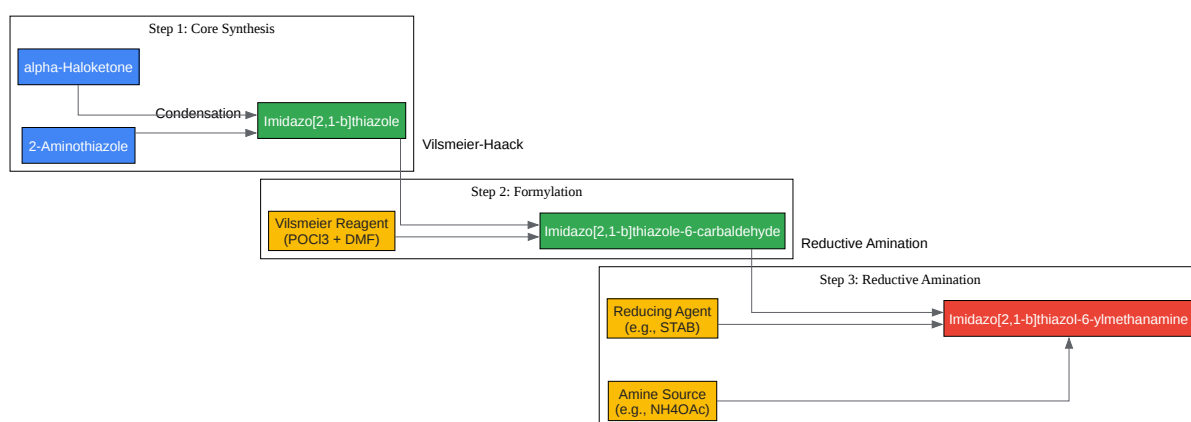

[Click to download full resolution via product page](#)

Caption: Synthetic pathway for **Imidazo[2,1-b]thiazol-6-ylmethanamine**.

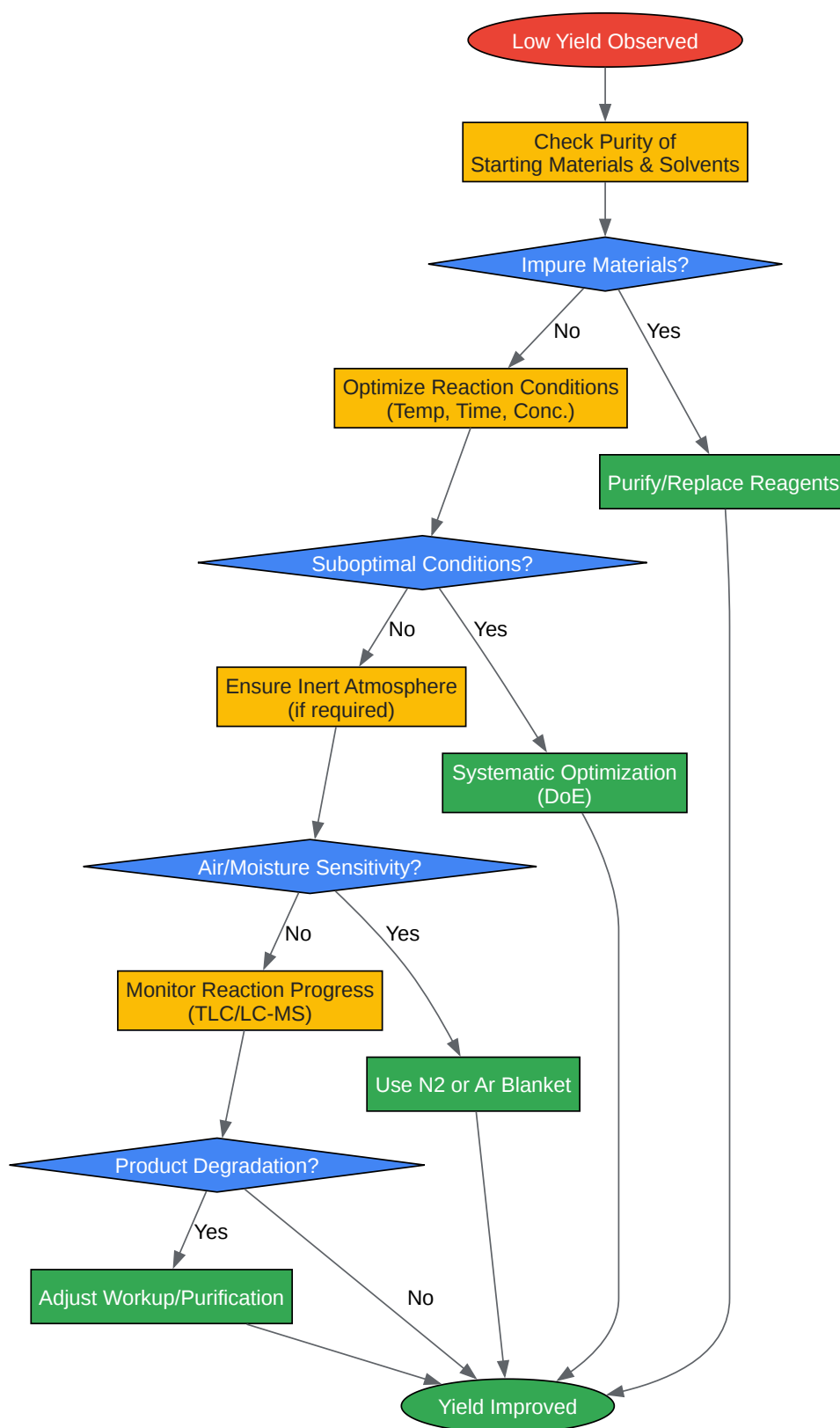

[Click to download full resolution via product page](#)

Caption: Troubleshooting workflow for low yield issues.

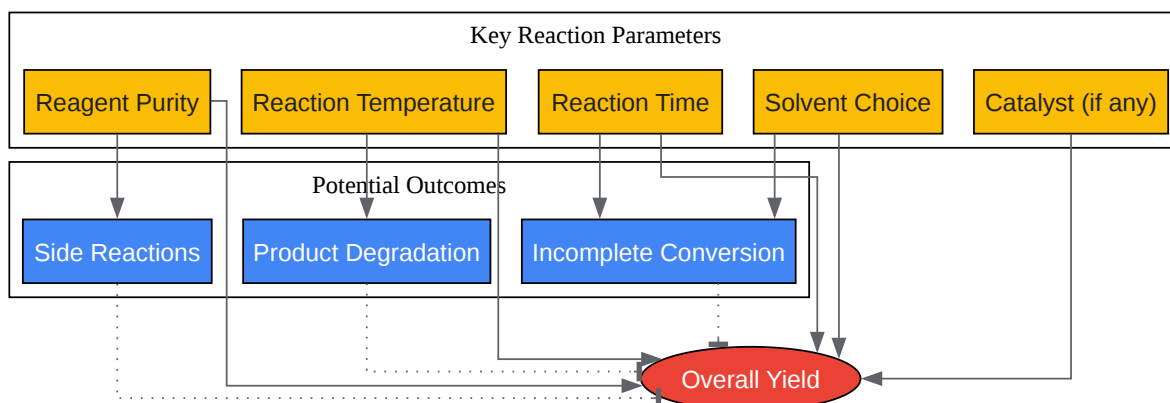

[Click to download full resolution via product page](#)

Caption: Logical relationships affecting reaction yield.

Need Custom Synthesis?

BenchChem offers custom synthesis for rare earth carbides and specific isotopic labeling.

Email: info@benchchem.com or [Request Quote Online](#).

References

- 1. researchgate.net [researchgate.net]
- 2. researchgate.net [researchgate.net]
- To cite this document: BenchChem. [Technical Support Center: Synthesis of Imidazo[2,1-b]thiazol-6-ylmethanamine]. BenchChem, [2026]. [Online PDF]. Available at: [<https://www.benchchem.com/product/b1309308#improving-the-yield-of-imidazo-2-1-b-thiazol-6-ylmethanamine-synthesis>]

Disclaimer & Data Validity:

The information provided in this document is for Research Use Only (RUO) and is strictly not intended for diagnostic or therapeutic procedures. While BenchChem strives to provide accurate protocols, we make no warranties, express or implied, regarding the fitness of this product for every specific experimental setup.

Technical Support: The protocols provided are for reference purposes. Unsure if this reagent suits your experiment? [[Contact our Ph.D. Support Team for a compatibility check](#)]

Need Industrial/Bulk Grade? [Request Custom Synthesis Quote](#)

BenchChem

Our mission is to be the trusted global source of essential and advanced chemicals, empowering scientists and researchers to drive progress in science and industry.

Contact

Address: 3281 E Guasti Rd
Ontario, CA 91761, United States
Phone: (601) 213-4426
Email: info@benchchem.com