

Navigating the Labyrinth of S1P Quantification: A Comparative Guide to Leading Methodologies

Author: BenchChem Technical Support Team. **Date:** April 2026

Compound of Interest

Compound Name: *Sphingosine-1-phosphate (d17:1)*

Cat. No.: *B1309150*

[Get Quote](#)

For researchers, scientists, and drug development professionals, the precise quantification of Sphingosine-1-phosphate (S1P) is paramount to unraveling its complex roles in health and disease. This guide provides an objective comparison of the most prevalent S1P quantification methods—Liquid Chromatography-Tandem Mass Spectrometry (LC-MS/MS), Enzyme-Linked Immunosorbent Assay (ELISA), and Fluorescence-Based Assays—supported by a detailed analysis of their performance and experimental protocols.

Sphingosine-1-phosphate is a critical bioactive signaling lipid that regulates a vast array of physiological processes, including cell proliferation, migration, and immune responses.^{[1][2]} Consequently, the accurate measurement of S1P levels in biological samples is essential for advancing our understanding of its function and for the development of novel therapeutics. The choice of quantification method can significantly impact experimental outcomes, making a thorough understanding of each technique's strengths and limitations crucial.

Performance Comparison of S1P Quantification Methods

The selection of an appropriate S1P quantification method hinges on a variety of factors, including the required sensitivity, specificity, sample throughput, and cost. The following table

summarizes the key performance characteristics of LC-MS/MS, ELISA, and fluorescence-based assays.

Feature	LC-MS/MS	ELISA	Fluorescence-Based Assays
Principle	Separation by chromatography, detection by mass-to-charge ratio	Antigen-antibody binding, enzymatic colorimetric detection	Detection of fluorescently labeled S1P analogs or receptor binding
Specificity	Very High	High (Antibody dependent)	Moderate to High (Probe dependent)
Sensitivity (LLOQ)	~0.01 - 0.05 μM [3][4]	~1.875 - 4.73 ng/mL (~0.005 - 0.012 μM)[5][6]	Method dependent, often used for relative quantification
Accuracy	High (<15% deviation)[7]	Good (Typically 80-120% recovery)[8][9]	Variable, often used for functional readouts
Precision (%CV)	High (<15%)[7]	Good (<10-15%)[9]	Variable
Sample Throughput	Low to Medium	High	High
Cost per Sample	High	Moderate	Low to Moderate
Expertise Required	High	Low to Moderate	Moderate

Experimental Methodologies

Liquid Chromatography-Tandem Mass Spectrometry (LC-MS/MS)

LC-MS/MS is widely considered the "gold standard" for S1P quantification due to its high specificity and sensitivity.[10][11]

Sample Preparation:

- Spiking with Internal Standard: To a biological sample (e.g., 100 μ L of plasma), add a known amount of a stable isotope-labeled internal standard (e.g., S1P-d7).[4]
- Protein Precipitation: Precipitate proteins by adding an organic solvent such as methanol.[3]
- Lipid Extraction: Perform a liquid-liquid extraction using a solvent system like chloroform/methanol to isolate the lipid fraction containing S1P.[10]
- Solvent Evaporation and Reconstitution: Evaporate the organic solvent under a stream of nitrogen and reconstitute the lipid extract in a solvent compatible with the LC mobile phase. [11]

LC-MS/MS Analysis:

- Chromatographic Separation: Inject the reconstituted sample onto a reverse-phase C18 column. Use a gradient elution with a mobile phase consisting of an aqueous component (e.g., water with 0.1% formic acid) and an organic component (e.g., methanol with 0.1% formic acid) to separate S1P from other lipids.[7]
- Mass Spectrometric Detection: Introduce the eluent into a tandem mass spectrometer. Use electrospray ionization (ESI) in the positive ion mode. Monitor the specific precursor-to-product ion transitions for both S1P and the internal standard using Multiple Reaction Monitoring (MRM).[12]

Enzyme-Linked Immunosorbent Assay (ELISA)

ELISA offers a higher throughput and more user-friendly alternative to LC-MS/MS for S1P quantification. Several commercial kits are available, and the general protocol is as follows.[13]

Assay Procedure (Competitive ELISA):

- Sample and Standard Preparation: Prepare a series of S1P standards of known concentrations. Dilute biological samples as required.
- Competitive Binding: Add the standards and samples to the wells of a microplate pre-coated with an S1P-specific antibody. Then, add a fixed amount of biotinylated S1P. During

incubation, the S1P in the sample and the biotinylated S1P compete for binding to the antibody.[9]

- **Washing:** Wash the plate to remove unbound components.
- **Enzyme Conjugate Addition:** Add a streptavidin-horseradish peroxidase (HRP) conjugate, which binds to the biotinylated S1P captured by the antibody.
- **Substrate Reaction:** After another wash step, add a chromogenic substrate (e.g., TMB). The HRP enzyme catalyzes a color change that is inversely proportional to the amount of S1P in the sample.
- **Detection:** Stop the reaction and measure the absorbance at a specific wavelength (e.g., 450 nm) using a microplate reader. The concentration of S1P in the samples is determined by interpolating from the standard curve.[14]

Fluorescence-Based Assays

Fluorescence-based methods are primarily employed to measure the activity of S1P transporters or to visualize S1P receptor dynamics rather than for the absolute quantification of endogenous S1P levels.

S1P Transporter Activity Assay:

- **Cell Incubation:** Incubate cells (e.g., erythrocytes) with a fluorescent S1P analog, such as NBD-S1P.
- **Measurement of Extracellular Fluorescence:** Over time, measure the increase in fluorescence in the extracellular medium using a fluorescence plate reader. This increase corresponds to the transport of the fluorescent S1P analog out of the cells.
- **Data Analysis:** The rate of increase in fluorescence provides a measure of S1P transporter activity.

Visualizing S1P Biology and Quantification Workflows

To further elucidate the context of S1P quantification, the following diagrams illustrate the S1P signaling pathway and a general experimental workflow.

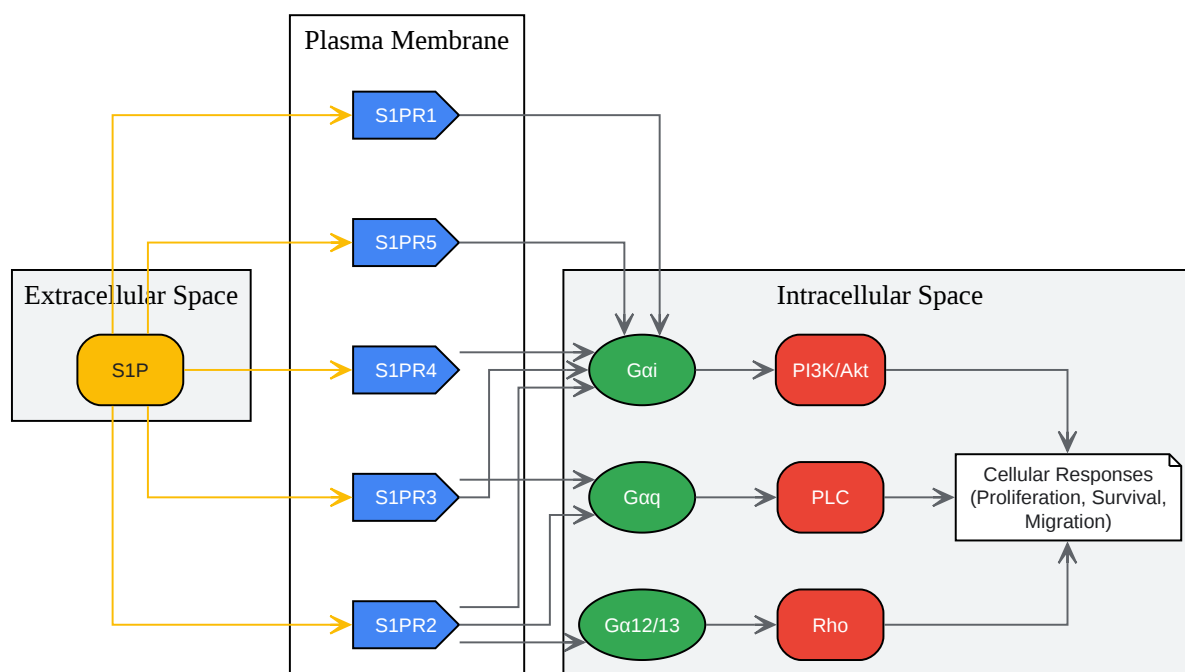

[Click to download full resolution via product page](#)

S1P Signaling Pathway

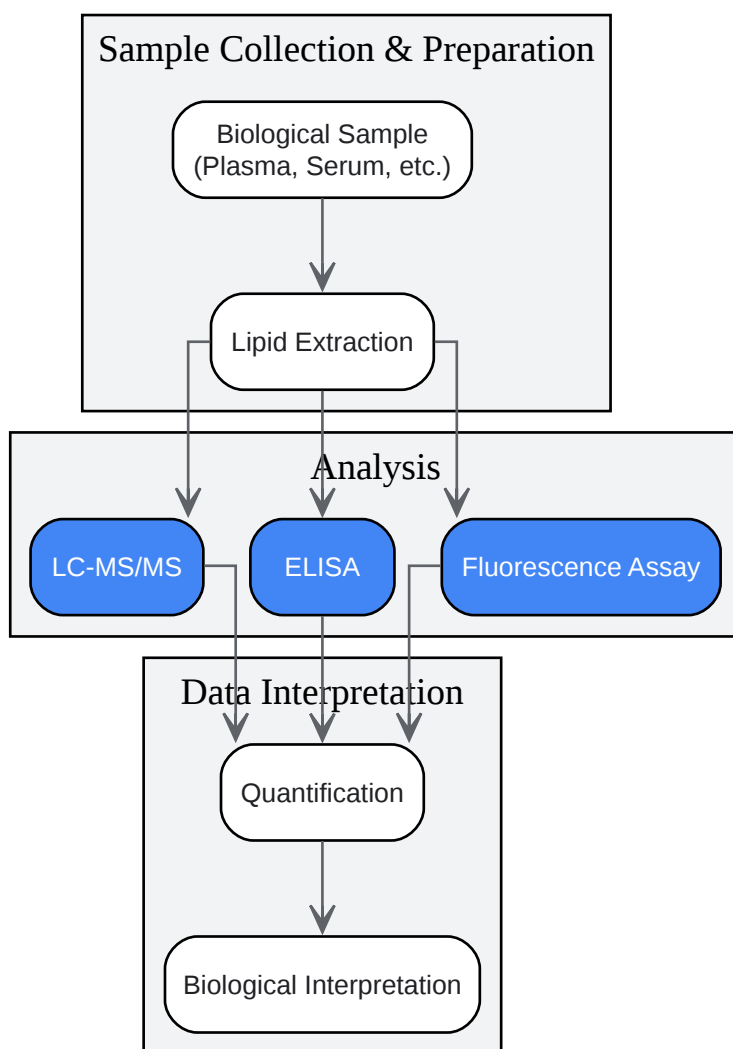

[Click to download full resolution via product page](#)

Need Custom Synthesis?

BenchChem offers custom synthesis for rare earth carbides and specific isotopic labeling.

Email: info@benchchem.com or [Request Quote Online](#).

References

- 1. Fluorescence-based rapid measurement of sphingosine-1-phosphate transport activity in erythrocytes - PMC [[pmc.ncbi.nlm.nih.gov](https://pubmed.ncbi.nlm.nih.gov/)]

- 2. Quantification of sphingosine 1-phosphate by validated LC-MS/MS method revealing strong correlation with apolipoprotein M in plasma but not in serum due to platelet activation during blood coagulation - PubMed [pubmed.ncbi.nlm.nih.gov]
- 3. researchgate.net [researchgate.net]
- 4. Real-world comparison of lymphopenia profiles in S1P receptor modulators for multiple sclerosis: a multicenter retrospective study - PMC [pmc.ncbi.nlm.nih.gov]
- 5. Cross-Validation of a Multiplex LC-MS/MS Method for Assaying mAbs Plasma Levels in Patients with Cancer: A GPCO-UNICANCER Study - PubMed [pubmed.ncbi.nlm.nih.gov]
- 6. "Comparison of Six Commercial Sesame ELISA Kits on Their Reliability of" by Janine L. Merkle, Joseph Baumert et al. [digitalcommons.unl.edu]
- 7. researchgate.net [researchgate.net]
- 8. tools.thermofisher.com [tools.thermofisher.com]
- 9. Validated LC-MS/MS method of Sphingosine 1-phosphate quantification in human serum for evaluation of response to radiotherapy in lung cancer - PMC [pmc.ncbi.nlm.nih.gov]
- 10. An assay system for measuring the acute production of sphingosine-1-phosphate in intact monolayers - PMC [pmc.ncbi.nlm.nih.gov]
- 11. researchgate.net [researchgate.net]
- 12. Sphingosine 1-Phosphate ELISA Kit - Echelon Biosciences [echelon-inc.com]
- 13. A rapid fluorescence assay for sphingosine-1-phosphate lyase enzyme activity - PubMed [pubmed.ncbi.nlm.nih.gov]
- 14. mdpi.com [mdpi.com]
- To cite this document: BenchChem. [Navigating the Labyrinth of S1P Quantification: A Comparative Guide to Leading Methodologies]. BenchChem, [2026]. [Online PDF]. Available at: [https://www.benchchem.com/product/b1309150/docs#navigating-the-labyrinth-of-s1p-quantification-a-comparative-guide-to-leading-methodologies]

Disclaimer & Data Validity:

The information provided in this document is for Research Use Only (RUO) and is strictly not intended for diagnostic or therapeutic procedures. While BenchChem strives to provide accurate protocols, we make no warranties, express or implied, regarding the fitness of this product for every specific experimental setup.

Technical Support: The protocols provided are for reference purposes. Unsure if this reagent suits your experiment?

Need Industrial/Bulk Grade? [Request Custom Synthesis Quote](#)

BenchChem

Our mission is to be the trusted global source of essential and advanced chemicals, empowering scientists and researchers to drive progress in science and industry.

Contact

Address: 3281 E Guasti Rd
Ontario, CA 91761, United States
Phone: (601) 213-4426
Email: info@benchchem.com

[Contact our Ph.D. Support Team for a compatibility check](#)