

A Guide to Inter-laboratory Comparison of Isocyanate Analysis Methods

Author: BenchChem Technical Support Team. **Date:** May 2026

Compound of Interest

Compound Name:	2-Methoxy-5-methylphenyl isocyanate
CAS No.:	59741-04-7
Cat. No.:	B1307589

[Get Quote](#)

This guide provides a comparative overview of common analytical methods for the quantification of isocyanates in workplace air. The selection of an appropriate analytical technique is critical for accurate exposure assessment and is influenced by factors such as the specific isocyanate, required sensitivity, sample matrix, and available instrumentation. This document summarizes key performance characteristics and experimental protocols for several widely used methods to assist researchers, scientists, and drug development professionals in their analytical endeavors.

Data Presentation: A Comparative Summary of Analytical Methods

The following table summarizes typical performance characteristics of various validated methods for the analysis of isocyanates. It is important to note that this data is compiled from individual method validation documents and not from a single, direct inter-laboratory comparison study. Performance characteristics can vary based on the specific isocyanate, laboratory conditions, and instrumentation.

Validation Parameter	NIOSH Method 5521	OSHA Method 42	ASTM D5932	ISO 17734-1
Derivatizing Agent	1-(2-Methoxyphenyl)piperazine (MPP)	1-(2-Pyridyl)piperazine (1-2PP)	9-(N-Methylaminomethyl) anthracene (MAMA)	Dibutylamine (DBA)
Sampling Media	Impinger with toluene solution	Glass fiber filter coated with 1-2PP	Glass fiber filter coated with MAMA	Dry sampler with DBA-impregnated media
Analytical Technique	HPLC with UV and Electrochemical Detection (EC)	HPLC with UV or Fluorescence Detection (FLD)	HPLC with UV and Fluorescence Detection (FLD)	Liquid Chromatography-Mass Spectrometry (LC-MS)
Limit of Detection (LOD)	2,4-TDI: 0.2 µg/sample ; 2,6-TDI: 0.2 µg/sample ; MDI: 0.09 µg/sample ; HDI: 0.3 µg/sample [1]	2,6-TDI: 1.6 µg/m ³ ; HDI: 2.3 µg/m ³ ; 2,4-TDI: 1.3 µg/m ³ (for a 15L air sample) [2]	2,6-TDI (UV): 0.007 µg/2mL; 2,4-TDI (UV): Not Specified; 2,6-TDI (FLD): 0.003 µg/2mL; 2,4-TDI (FLD): Not Specified[3]	0.005 µg/sampler (for most compounds)[4]
Limit of Quantification (LOQ)	2,4-TDI: 0.5 µg/sample ; 2,6-TDI: 0.7 µg/sample ; MDI: 0.3 µg/sample ; HDI: 1.0 µg/sample [1]	2,6-TDI: 2.3 µg/m ³ ; HDI: 2.9 µg/m ³ ; 2,4-TDI: 2.5 µg/m ³ (for a 15L air sample) [2]	2,6-TDI (UV): 0.007 µg/2mL, which corresponds to 0.0005 mg/m ³ for a 15-L air sample[3]	Isocyanic acid: 0.3 µg/sampler ; Propyl isocyanate: 0.02 µg/sampler ; Other compounds: <0.005 µg/sampler [4]
Precision	Not specified in provided results.	Not specified in provided results.	Correlation coefficients	Not specified in provided results.

			>0.98 for calibration curves[3]	
Accuracy	Sample instability observed at room temperature.[1]	Overall accuracy within $\pm 25\%$ [3]	Validated for 0.029 to 1.16 μg of monomeric 2,4- and 2,6-TDI per 2.0 mL of desorption solution[5]	Not specified in provided results.
Recovery	Not specified in provided results.	Not specified in provided results.	Not specified in provided results.	Not specified in provided results.

Experimental Protocols

Detailed methodologies are crucial for the replication and validation of analytical results. Below are summaries of the experimental protocols for the key methods cited.

NIOSH Method 5521

- Principle: This method uses an impinger containing 1-(2-methoxyphenyl)piperazine (MPP) in toluene to collect and derivatize airborne isocyanates. The resulting stable urea derivatives are then analyzed by High-Performance Liquid Chromatography (HPLC) with ultraviolet (UV) and electrochemical (EC) detectors.[1]
- Sampling: Air is drawn through a midjet impinger containing the MPP/toluene solution at a flow rate of 1 L/min.
- Sample Preparation: The impinger solution is transferred to a vial, and the solvent is evaporated. The residue is redissolved in a suitable solvent for HPLC analysis.
- Analysis: The prepared sample is injected into an HPLC system. The separation of the isocyanate-urea derivatives is achieved on a C18 column with a mobile phase gradient. Detection is performed using a UV detector followed by an EC detector for enhanced sensitivity and selectivity.[1]

- Quality Control: Field blanks are collected and analyzed with the samples. Calibration standards are prepared from the corresponding isocyanate-urea derivatives.

OSHA Method 42

- Principle: This method involves drawing air through a glass fiber filter coated with 1-(2-pyridyl)piperazine (1-2PP) to trap and derivatize isocyanates. The resulting derivatives are desorbed and analyzed by HPLC with UV or fluorescence detection.[2]
- Sampling: Air is sampled using a 37-mm glass fiber filter coated with 1-2PP in a three-piece cassette, typically at a flow rate of 1 L/min.[6]
- Sample Preparation: The filter is transferred to a vial, and the derivatives are desorbed using a mixture of acetonitrile and dimethyl sulfoxide (DMSO).[6]
- Analysis: An aliquot of the desorbed sample is injected into an HPLC system equipped with a C18 column and a UV or fluorescence detector.
- Quality Control: Field blanks and spiked samples are used to assess contamination and recovery. A calibration curve is generated using standards of the isocyanate-1-2PP derivatives.

ASTM D5932

- Principle: This method is designed for the determination of gaseous 2,4-toluene diisocyanate (2,4-TDI) and 2,6-toluene diisocyanate (2,6-TDI). It uses a glass fiber filter impregnated with 9-(N-methylaminomethyl) anthracene (MAMA) for collection and derivatization. Analysis is performed by HPLC with UV and fluorescence detectors.[5]
- Sampling: Air is drawn through the MAMA-impregnated filter. This method can be used with a segregating device to separate the gaseous and aerosol fractions.[5]
- Sample Preparation: The filter is extracted with a suitable solvent to dissolve the MAMA derivatives.
- Analysis: The extract is analyzed by HPLC, and the use of both UV and fluorescence detectors provides high sensitivity and specificity for the TDI-MAMA derivatives.[5]

- Quality Control: The use of field blanks is required to check for contamination. The method is validated over a concentration range relevant to occupational exposure limits.[5]

ISO 17734-1

- Principle: This international standard describes a method using a dry sampler for the collection of a wide range of airborne isocyanates. The sampler contains a medium impregnated with dibutylamine (DBA), which derivatizes both gaseous and particulate isocyanates. The resulting DBA-urea derivatives are analyzed by Liquid Chromatography-Mass Spectrometry (LC-MS).[4][7]
- Sampling: A dry sampler is used with a personal sampling pump. The design of the sampler allows for the collection of both vapor and particulate phases.[4]
- Sample Preparation: The sampling medium is extracted with an acidified methanol solution, followed by a liquid-liquid extraction. The final extract is reconstituted in acetonitrile for analysis.[4]
- Analysis: The analysis is performed by LC-MS or LC-MS/MS, which provides high sensitivity and selectivity for the various isocyanate-DBA derivatives.[7]
- Quality Control: Blank samplers are analyzed to determine background levels. The method has been validated for a range of monomeric and oligomeric isocyanates.[4]

Visualizations

Workflow for Inter-laboratory Comparison

The following diagram illustrates a typical workflow for an inter-laboratory comparison or round-robin test for isocyanate analysis methods.

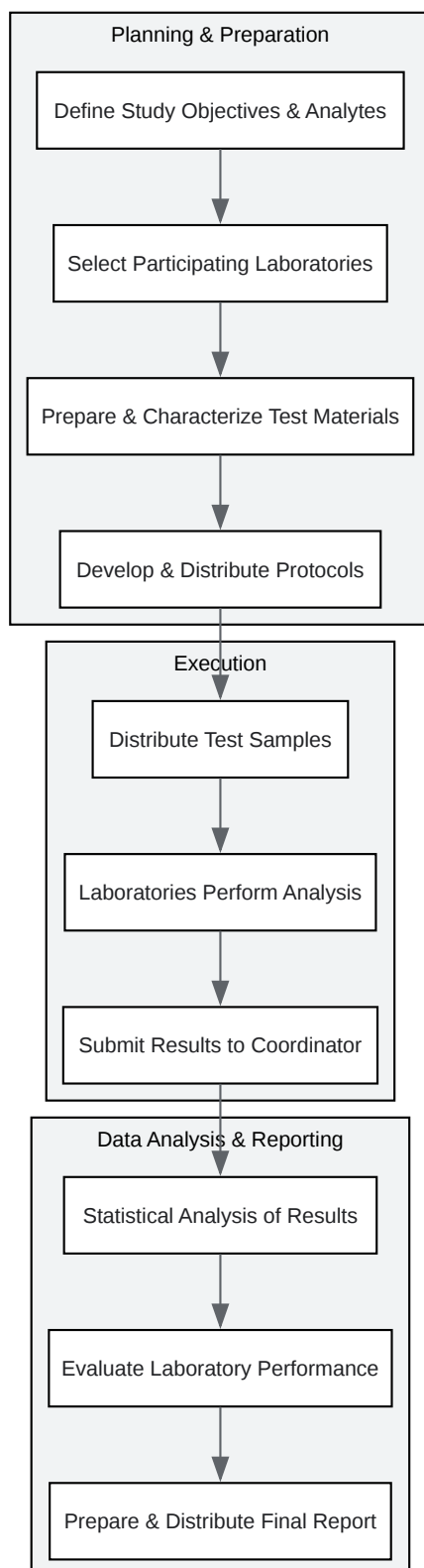

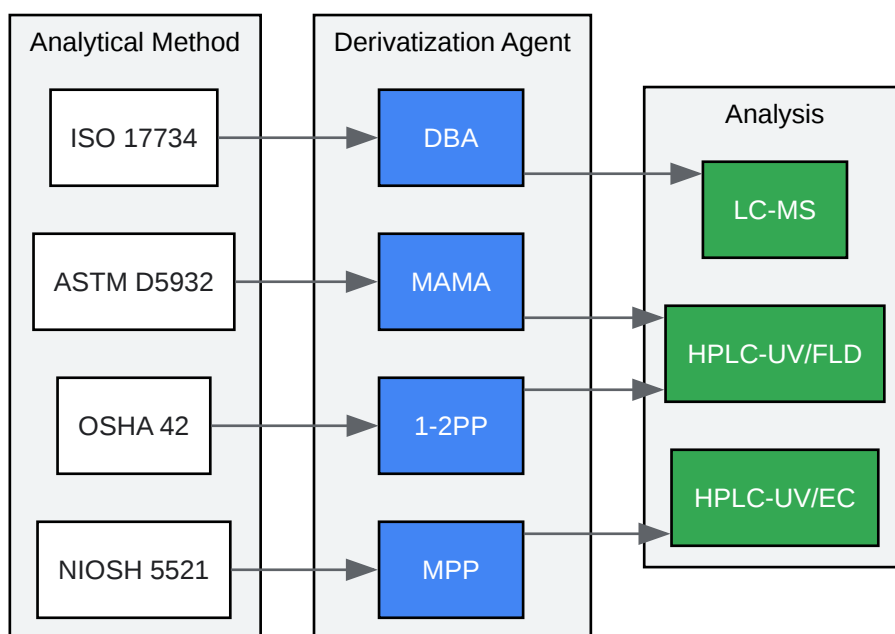

[Click to download full resolution via product page](#)

Need Custom Synthesis?

BenchChem offers custom synthesis for rare earth carbides and specific isotopic labeling.

Email: info@benchchem.com or [Request Quote Online](#).

References

- [1. cdc.gov \[cdc.gov\]](https://www.cdc.gov)
- [2. osha.gov \[osha.gov\]](https://www.osha.gov)
- [3. webstore.ansi.org \[webstore.ansi.org\]](https://www.webstore.ansi.org)
- [4. sgs.co.uk \[sgs.co.uk\]](https://www.sgs.co.uk)
- [5. standards.iteh.ai \[standards.iteh.ai\]](https://standards.iteh.ai)
- [6. americanchemistry.com \[americanchemistry.com\]](https://www.americanchemistry.com)
- [7. cawood.co.uk \[cawood.co.uk\]](https://www.cawood.co.uk)
- To cite this document: BenchChem. [A Guide to Inter-laboratory Comparison of Isocyanate Analysis Methods]. BenchChem, [2026]. [Online PDF]. Available at:

[\[https://www.benchchem.com/product/b1307589/docs#a-guide-to-inter-laboratory-comparison-of-isocyanate-analysis-methods\]](https://www.benchchem.com/product/b1307589/docs#a-guide-to-inter-laboratory-comparison-of-isocyanate-analysis-methods)

Disclaimer & Data Validity:

The information provided in this document is for Research Use Only (RUO) and is strictly not intended for diagnostic or therapeutic procedures. While BenchChem strives to provide accurate protocols, we make no warranties, express or implied, regarding the fitness of this product for every specific experimental setup.

Technical Support: The protocols provided are for reference purposes. Unsure if this reagent suits your experiment?

Need Industrial/Bulk Grade? [Request Custom Synthesis Quote](#)

BenchChem

Our mission is to be the trusted global source of essential and advanced chemicals, empowering scientists and researchers to drive progress in science and industry.

Contact

Address: 3281 E Guasti Rd
Ontario, CA 91761, United States
Phone: (601) 213-4426
Email: info@benchchem.com

[Contact our Ph.D. Support Team for a compatibility check](#)