

comparative study of fluorogenic labeling reagents for peptide analysis

Author: BenchChem Technical Support Team. **Date:** May 2026

Compound of Interest

Compound Name: 4-Fluoro-3,5-dinitrobenzoic acid

CAS No.: 2365-71-1

Cat. No.: B1306746

[Get Quote](#)

Comparative Guide: Fluorogenic Labeling Reagents for Peptide Analysis

Executive Summary

In high-sensitivity peptide analysis—particularly for capillary electrophoresis (CE) and micro-LC workflows—native fluorescence (tryptophan/tyrosine) is often insufficient. Derivatization with fluorogenic reagents (compounds that are non-fluorescent until reaction) is the standard solution.^[1]

This guide evaluates the four dominant dialdehyde-based reagents. OPA (o-Phthalaldehyde) remains the industry workhorse for routine, automated pre-column amino acid analysis due to its rapid kinetics. However, for high-sensitivity proteomics and stable adduct formation, NDA (Naphthalene-2,3-dicarboxaldehyde) and FQ (3-(2-Furoyl)quinoline-2-carboxaldehyde) are superior choices. They offer higher quantum yields, red-shifted emission spectra (reducing background interference), and significantly improved derivative stability compared to the transient isoindoles formed by OPA.

Mechanism of Action: The Dialdehyde Pathway

The chemical basis for all four reagents is remarkably similar. They utilize a dialdehyde core that undergoes a condensation reaction with a primary amine (N-terminus or Lysine side chain) and a nucleophile (typically a thiol or cyanide) to form a highly fluorescent isoindole or benzoisoindole structure.

Reaction Topology

The following diagram illustrates the divergent pathways based on the nucleophile selection, a critical decision point for stability.

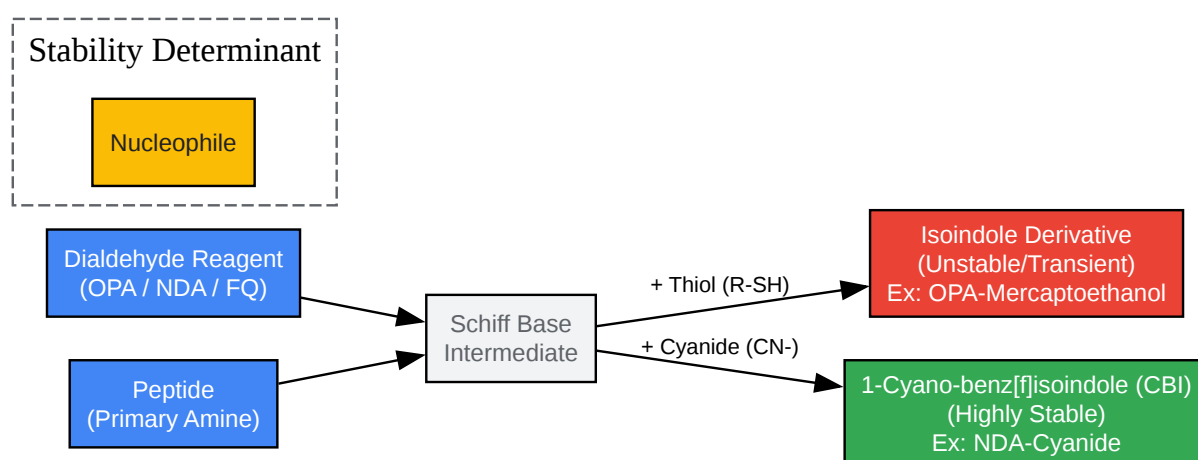

[Click to download full resolution via product page](#)

Figure 1: General reaction mechanism. Note that while OPA typically uses thiols (creating unstable derivatives), NDA and FQ utilize cyanide to create stable cyanobenz[f]isoindole structures.

Comparative Analysis of Reagents

OPA (o-Phthalaldehyde)[2][3][4][5]

- The Routine Workhorse.
- Chemistry: Reacts with primary amines + 2-mercaptoethanol (2-ME) or 3-mercaptopropionic acid (3-MPA).

- Pros: Reaction is essentially instantaneous (< 1 min). Ideal for automated on-line derivatization loops in HPLC. Water-soluble.[2][3]
- Cons: The resulting isoindole is chemically unstable and degrades into non-fluorescent products (half-life ~5-15 mins depending on conditions). Does not react with secondary amines (e.g., Proline).
- Best For: High-throughput amino acid analysis (AAA) where injection occurs immediately after mixing.

NDA (Naphthalene-2,3-dicarboxaldehyde)[2][4][5]

- The High-Performance Upgrade.
- Chemistry: Analog of OPA but uses a naphthalene ring. Reacts with cyanide (CN-) to form a CBI derivative.
- Pros: Forms an extremely stable product (stable for >10 hours). Higher quantum yield than OPA. Emission is red-shifted (~490 nm), moving away from UV background interference.
- Cons: Slower reaction kinetics (~15-20 mins). Requires cyanide (toxicity concerns, though mandelonitrile is a safer alternative).
- Best For: Trace analysis, overnight runs, and LC-MS applications where derivative stability is crucial.

CBQCA & ATTO-TAG FQ

- The Ultrasensitive Specialists.
- Chemistry: Quinoline-based dialdehydes.
- Pros: Designed for capillary electrophoresis (CE) and laser-induced fluorescence (LIF). Detection limits in the attomole range.[4] Longest emission wavelengths (550–590 nm), virtually eliminating biological background fluorescence.
- Cons: Expensive. Long reaction times (often 1 hour).

- Best For: Single-cell analysis, micro-dialysis samples, and CE-LIF.

Performance Metrics Matrix

Feature	OPA (o-Phthalaldehyde)	NDA	ATTO-TAG FQ
Excitation Max	340 nm (UV)	420–440 nm	480 nm
Emission Max	455 nm	490 nm	590 nm
Nucleophile	Thiol (2-ME, 3-MPA)	Cyanide (CN ⁻)	Cyanide (CN ⁻)
Reaction Time	< 1 minute	15–20 minutes	~60 minutes
Derivative Stability	Poor (Minutes)	Excellent (>10 Hours)	Excellent (>10 Hours)
LOD (Sensitivity)	Femtomole ()	Low Femtomole	Attomole ()
Major Limitation	Unstable signal; UV interference	Cyanide toxicity	Cost; Incubation time

Experimental Protocols

Workflow Decision Logic

Before selecting a protocol, verify your instrumentation path.

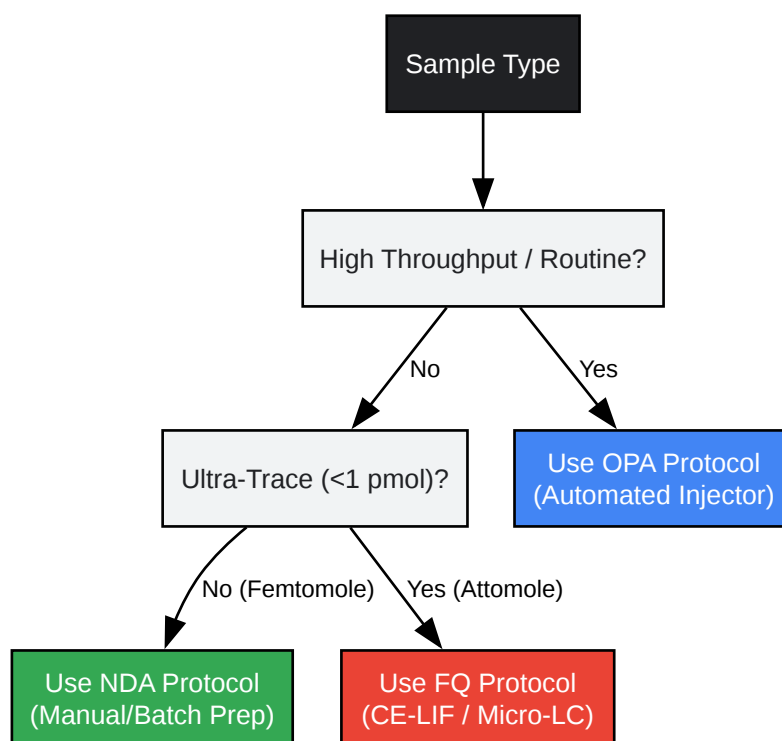

[Click to download full resolution via product page](#)

Figure 2: Reagent selection logic based on throughput and sensitivity requirements.

Protocol A: High-Stability Labeling with NDA

Recommended for batch processing of peptides prior to LC separation.

Reagents:

- Borate Buffer: 100 mM, pH 9.5 (High pH is critical for deprotonation of amines).
- KCN Solution: 10 mM Potassium Cyanide in water. (Caution: Toxic).
- NDA Solution: 10 mM NDA in HPLC-grade Acetonitrile.

Procedure:

- Preparation: Dissolve peptide sample in Borate Buffer to a concentration of ~1–10 μM .
- Mixture: In a microvial, combine:

- 20 μ L Peptide Sample
- 10 μ L KCN Solution
- 10 μ L NDA Solution
- Note: Maintain a molar excess of reagents (at least 10-fold over amines).
- Incubation: Vortex and incubate in the dark at room temperature for 20 minutes.
 - Why? Unlike OPA, the formation of the benz[*f*]isoindole ring is slower but yields a product that does not degrade during the HPLC run.
- Quenching (Optional): If precise kinetics are required, add 50 μ L of 1% acetic acid, though NDA derivatives are stable enough that this is often unnecessary for LC.
- Analysis: Inject 10 μ L onto C18 HPLC column. Detect at Ex 420 nm / Em 490 nm.

Protocol B: Rapid On-Line Labeling with OPA

Recommended for automated HPLC autosamplers.

Reagents:

- OPA Reagent: 10 mg OPA dissolved in 0.5 mL Methanol, diluted to 10 mL with 0.4 M Borate buffer (pH 10.4). Add 50 μ L 2-Mercaptoethanol (2-ME).
 - Stability Note: This reagent degrades oxidatively. Prepare fresh daily.

Procedure:

- Automation: Program the autosampler to draw 10 μ L sample + 10 μ L OPA Reagent.
- Mixing: Perform "mix in loop" or vial mixing cycles (3x).
- Wait: Program a wait time of exactly 1.0 minute.
 - Critical: OPA fluorescence peaks quickly and then decays. The timing between mix and injection must be identical for every sample to ensure reproducibility.

- Injection: Inject immediately. Detect at Ex 340 nm / Em 455 nm.[5]

Critical Discussion & Troubleshooting

The "Quenching" Myth vs. Reality

A common error in OPA analysis is "quenching" the reaction with acid to stabilize it. While acidification stops the reaction, it often accelerates the degradation of the OPA-isoindole derivative. Trustworthiness check: For OPA, strict timing control is superior to chemical quenching. For NDA/FQ, the product is stable enough that quenching is rarely the source of error.

LC-MS Compatibility

While these reagents are fluorogenic, they also add mass and hydrophobicity, which can be advantageous for LC-MS:

- NDA: Adds a hydrophobic naphthalene ring, significantly increasing retention on C18 columns. This is useful for retaining small, hydrophilic peptides that usually elute in the void volume.
- Ionization: The nitrogen in the isoindole ring is easily protonated, often enhancing ESI-MS signal intensity compared to the native peptide.

Interferences

- Buffers: Avoid Tris or Glycine buffers during the labeling step, as they contain primary amines that will consume the reagent. Use Borate, Carbonate, or Phosphate.
- Tryptophan: Standard NDA/OPA protocols react poorly with Indoles. If Tryptophan quantification is critical, inclusion of cyclodextrins in the NDA reaction buffer has been shown to enhance fluorescence yield [2].[5][6]

References

- Roth, M. (1971).[7] Fluorescence reaction for amino acids. Analytical Chemistry. [Link](#)
- De Montigny, P., et al. (1987). Naphthalene-2,3-dicarboxaldehyde/cyanide ion: a rationally designed fluorogenic reagent for primary amines. Analytical Chemistry. [Link](#)

- You, J., et al. (1997).[5] 3-(4-Carboxybenzoyl)quinoline-2-carboxaldehyde (CBQCA) as a fluorogenic reagent.[8][5][4] Analytical Biochemistry. [Link](#)
- Thermo Fisher Scientific. (2024). ATTO-TAG™ FQ Amine-Derivatization Kit Product Information. [Link](#)
- Benson, J. R., & Hare, P. E. (1975). o-Phthalaldehyde: fluorogenic detection of primary amines in the picomole range.[3] Proceedings of the National Academy of Sciences. [Link](#)

Need Custom Synthesis?

BenchChem offers custom synthesis for rare earth carbides and specific isotopic labeling.

Email: info@benchchem.com or [Request Quote Online](#).

Sources

- 1. interchim.fr [interchim.fr]
- 2. Protein Quantitation in Solution—Section 9.2 | Thermo Fisher Scientific - US [thermofisher.com]
- 3. O-phthalaldehyde: fluorogenic detection of primary amines in the picomole range. Comparison with fluorescamine and ninhydrin - PMC [pmc.ncbi.nlm.nih.gov]
- 4. documents.thermofisher.com [documents.thermofisher.com]
- 5. researchgate.net [researchgate.net]
- 6. A comparison of fluorescamine and naphthalene-2,3-dicarboxaldehyde fluorogenic reagents for microplate-based detection of amino acids - PubMed [pubmed.ncbi.nlm.nih.gov]
- 7. escholarship.org [escholarship.org]
- 8. documents.thermofisher.com [documents.thermofisher.com]
- To cite this document: BenchChem. [comparative study of fluorogenic labeling reagents for peptide analysis]. BenchChem, [2026]. [Online PDF]. Available at: [<https://www.benchchem.com/product/b1306746/docs#comparative-study-of-fluorogenic-labeling-reagents-for-peptide-analysis>]

Disclaimer & Data Validity:

The information provided in this document is for Research Use Only (RUO) and is strictly not intended for diagnostic or therapeutic procedures. While BenchChem strives to provide accurate protocols, we make no warranties, express or implied, regarding the fitness of this product for every specific experimental setup.

Technical Support: The protocols provided are for reference purposes. Unsure if this reagent suits your experiment?

Need Industrial/Bulk Grade? [Request Custom Synthesis Quote](#)

BenchChem

Our mission is to be the trusted global source of essential and advanced chemicals, empowering scientists and researchers to drive progress in science and industry.

Contact

Address: 3281 E Guasti Rd
Ontario, CA 91761, United States
Phone: (601) 213-4426
Email: info@benchchem.com

[Contact our Ph.D. Support Team for a compatibility check](#)