

# Managing moisture sensitivity of 2-Fluoro-6-(trifluoromethyl)benzylamine

**Author:** BenchChem Technical Support Team. **Date:** January 2026

## Compound of Interest

Compound Name: 2-Fluoro-6-(trifluoromethyl)benzylamine

Cat. No.: B1305491

[Get Quote](#)

## Technical Support Center: 2-Fluoro-6-(trifluoromethyl)benzylamine

A Senior Application Scientist's Guide to Managing Moisture Sensitivity

Welcome to the technical support center for **2-Fluoro-6-(trifluoromethyl)benzylamine**. This guide is designed for researchers, scientists, and drug development professionals who utilize this versatile but sensitive building block. As a key intermediate in the synthesis of pharmaceuticals and agrochemicals, its integrity is paramount for reproducible and high-yielding results.<sup>[1]</sup> This document provides in-depth, field-proven insights into the challenges posed by its moisture sensitivity and offers robust solutions for its handling, storage, and use.

### Frequently Asked Questions (FAQs)

This section addresses the most common issues and questions encountered by users in the lab.

Q1: Why is **2-Fluoro-6-(trifluoromethyl)benzylamine** so sensitive to moisture and air?

A1: The moisture sensitivity stems from the basic nature of the amine functional group. Like many amines, it is hygroscopic, meaning it readily absorbs moisture from the atmosphere.<sup>[2]</sup> This absorbed water can act as a competing nucleophile in reactions, lead to the formation of

hydrates, or facilitate other degradation pathways. Furthermore, the amine can react with atmospheric carbon dioxide to form a solid benzylammonium carbamate salt, which can affect stoichiometry and reaction kinetics.[3] While the electron-withdrawing fluoro- and trifluoromethyl groups reduce the basicity of the amine compared to benzylamine, this reactivity remains a critical factor to control.

Q2: How should I properly store **2-Fluoro-6-(trifluoromethyl)benzylamine** to ensure its long-term stability?

A2: Proper storage is the first line of defense against degradation. The compound should be stored in a tightly sealed container, preferably the original manufacturer's bottle (e.g., a Sure/Seal™ bottle), under a dry, inert atmosphere like argon or nitrogen.[4] For long-term stability, refrigeration at 0-8°C is recommended.[1] It is crucial to store it away from incompatible materials such as acids, acid chlorides, acid anhydrides, and strong oxidizing agents.[4]

Q3: What are the visible signs that my **2-Fluoro-6-(trifluoromethyl)benzylamine** has been compromised by moisture or air?

A3: The pure compound is typically a colorless to light yellow liquid.[1] Signs of degradation can include a change in color, an increase in viscosity, or the appearance of a solid precipitate. The precipitate is often the carbamate salt formed from a reaction with atmospheric CO<sub>2</sub>. [3] However, significant degradation can occur without obvious visual cues. Therefore, if moisture exposure is suspected, analytical verification is recommended before use.

Q4: My reaction yield is low and inconsistent. Could moisture be the culprit?

A4: Absolutely. This is a classic symptom of moisture contamination in reactions involving sensitive reagents.[5] Moisture can interfere in several ways:

- **Competing Nucleophile:** Water can compete with the benzylamine in nucleophilic substitution or addition reactions, leading to undesired hydroxylated byproducts and reduced yield of the target molecule.
- **Reagent Deactivation:** If your reaction involves other moisture-sensitive reagents (e.g., organometallics, strong bases like BuLi, or acyl chlorides), any introduced water will consume them, altering the stoichiometry and halting the reaction.

- **Catalyst Inhibition:** Certain catalysts used in cross-coupling or other reactions can be deactivated by water.

Q5: How can I confirm the purity of my amine if I suspect contamination?

A5: Several analytical techniques can be used to assess the purity and detect degradation products:

- **Gas Chromatography-Mass Spectrometry (GC-MS):** Ideal for identifying volatile impurities and degradation products.
- **High-Performance Liquid Chromatography (HPLC):** Useful for quantifying the primary component and detecting less volatile byproducts.[6]
- **Nuclear Magnetic Resonance (NMR) Spectroscopy:**  $^1\text{H}$  and  $^{19}\text{F}$  NMR can provide a clear picture of the compound's integrity and reveal the presence of impurities or degradation products through unexpected shifts or new signals.
- **Karl Fischer Titration:** This is the gold standard for accurately quantifying water content in the reagent.

## Key Properties and Storage Summary

Property	Value	Source(s)
CAS Number	239087-06-0	[1][4]
Molecular Formula	$\text{C}_8\text{H}_7\text{F}_4\text{N}$	[1][4]
Molecular Weight	193.14 g/mol	[1]
Appearance	Colorless to light yellow liquid	[1]
Storage Temperature	0 - 8 °C	[1]
Handling Conditions	Store under inert gas (Air sensitive)	[4]
Incompatibilities	Acids, acid chlorides, acid anhydrides, strong oxidizing agents	[4]

## Experimental Protocols and Troubleshooting

Adherence to rigorous technique is non-negotiable when working with moisture-sensitive compounds. The following protocols provide a self-validating framework for success.

### Protocol 1: Handling and Dispensing from a Sure/Seal™ Bottle

This protocol ensures the transfer of the amine without introducing atmospheric moisture or oxygen.[7]

- **Preparation:** Secure the Sure/Seal™ bottle to a clamp on a stand in a fume hood. Gather a clean, oven-dried syringe and a needle.
- **Inert Gas Line:** Prepare a balloon or Schlenk line filled with dry argon or nitrogen. Insert a needle connected to this line through the septum of the Sure/Seal™ bottle to create a slight positive pressure. This ensures that as you withdraw the liquid, it is replaced by inert gas, not air.
- **Syringe Purge:** Purge your syringe with the inert gas 3-5 times to remove any residual air and moisture.
- **Withdrawal:** Pierce the septum with the purged syringe needle and carefully withdraw the desired volume of **2-Fluoro-6-(trifluoromethyl)benzylamine**. Ensure the needle tip is below the liquid surface to avoid drawing gas.
- **Transfer:** Quickly transfer the reagent to the reaction vessel, which should already be under an inert atmosphere. Dispense the liquid down the inner wall of the flask.
- **Storage After Use:** Before removing the inert gas needle from the Sure/Seal™ bottle, pull back slightly on the syringe used for transfer to introduce some inert gas from the reaction flask's headspace, ensuring no reagent remains in the needle. Withdraw the syringe, then the inert gas needle. For added long-term protection, wrap the septum area with Parafilm.

### Protocol 2: Setting Up a Moisture-Sensitive Reaction

This workflow minimizes moisture exposure from glassware, solvents, and the atmosphere.[5]

- **Glassware Preparation:** All glassware (flasks, dropping funnels, condensers) must be thoroughly dried in an oven ( $\geq 120^{\circ}\text{C}$  for at least 4 hours) or by flame-drying under vacuum. Assemble the apparatus while hot and immediately place it under a positive pressure of dry inert gas.
- **Solvent Preparation:** Use anhydrous solvents. Pre-dried solvents can be purchased, or they can be dried using standard laboratory techniques, such as distillation from an appropriate drying agent or by passing them through a solvent purification system (SPS). Store dried solvents over molecular sieves under an inert atmosphere.
- **Atmosphere Control:** Connect the assembled apparatus to a Schlenk line or a dual manifold providing vacuum and inert gas.<sup>[7]</sup> Evacuate the apparatus and backfill with inert gas. Repeat this "purge cycle" at least three times to ensure the complete removal of air and residual moisture. Maintain a slight positive pressure of inert gas throughout the experiment, monitored with an oil bubbler.
- **Reagent Addition:**
  - **Liquids:** Add anhydrous solvents and liquid reagents (like **2-Fluoro-6-(trifluoromethyl)benzylamine**) via a dry syringe through a rubber septum, as described in Protocol 1.
  - **Solids:** Add solid reagents to the flask under a positive flow of inert gas to prevent air from entering the flask.

## Troubleshooting Guide

When experiments yield unexpected results, a systematic approach can identify the source of the problem.

Troubleshooting Workflow for Moisture-Related Issues

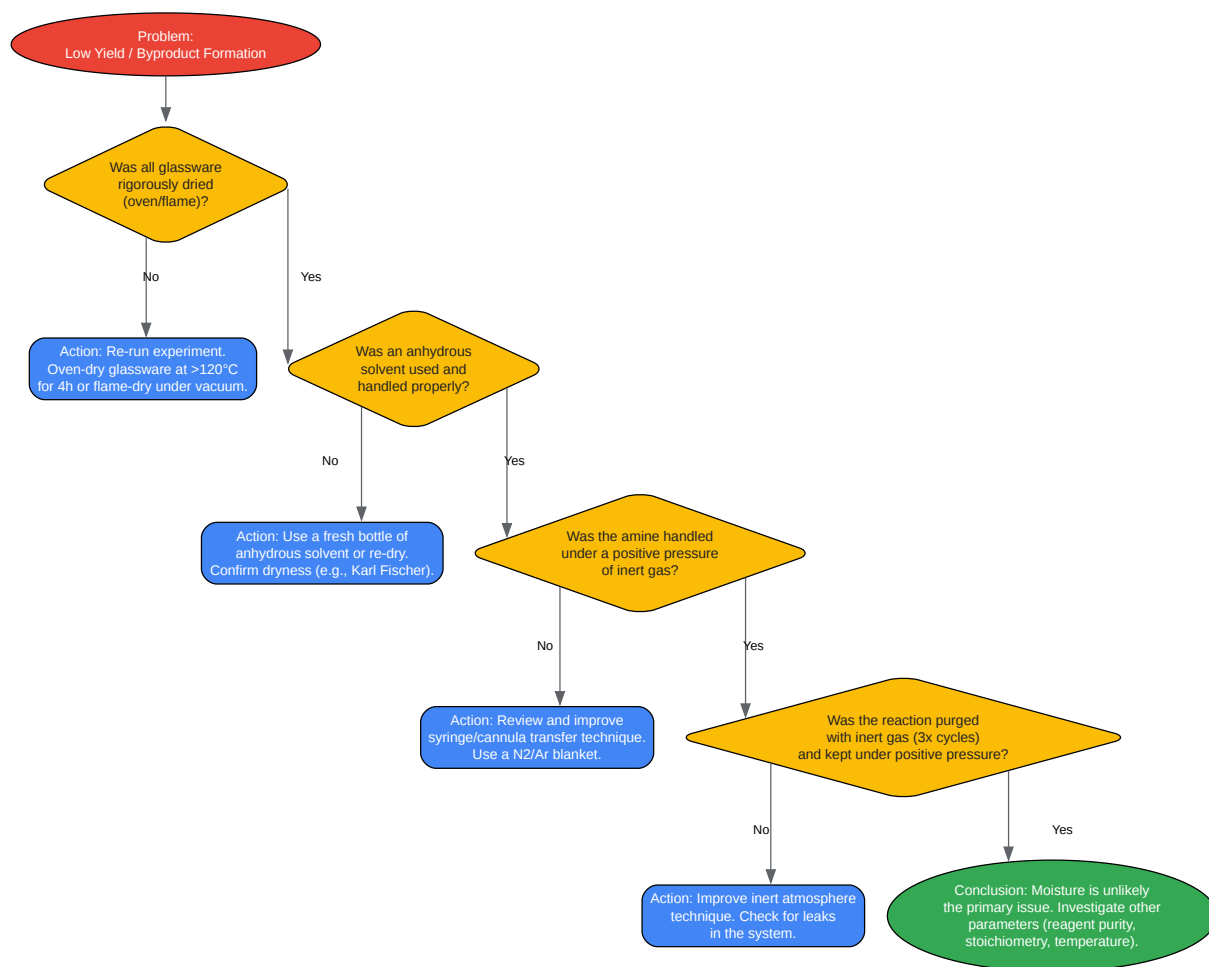

[Click to download full resolution via product page](#)

Caption: Troubleshooting logic for moisture-related issues.

## Reactions with Atmospheric Contaminants

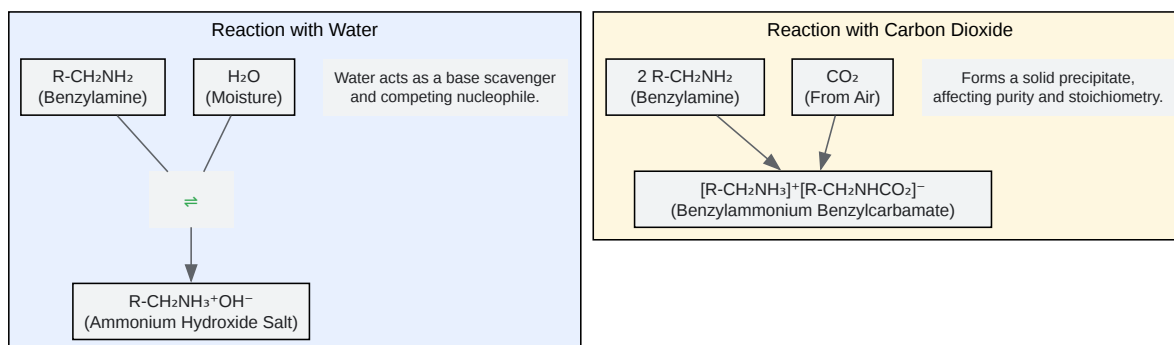

[Click to download full resolution via product page](#)

Caption: Degradation pathways with H<sub>2</sub>O and CO<sub>2</sub>.

### Need Custom Synthesis?

BenchChem offers custom synthesis for rare earth carbides and specific isotopic labeling.

Email: [info@benchchem.com](mailto:info@benchchem.com) or [Request Quote Online](#).

## References

1. chemimpex.com [chemimpex.com]
2. diplomatacomercial.com [diplomatacomercial.com]
3. Benzylamine: Properties, Preparation and Applications\_Chemicalbook [chemicalbook.com]
4. synquestlabs.com [synquestlabs.com]
5. pdf.benchchem.com [pdf.benchchem.com]
6. Critical study of and improvements in chromatographic methods for the analysis of type B trichothecenes. | Sigma-Aldrich [merckmillipore.com]

- 7. [ccc.chem.pitt.edu](http://ccc.chem.pitt.edu) [[ccc.chem.pitt.edu](http://ccc.chem.pitt.edu)]
- To cite this document: BenchChem. [Managing moisture sensitivity of 2-Fluoro-6-(trifluoromethyl)benzylamine]. BenchChem, [2026]. [Online PDF]. Available at: [<https://www.benchchem.com/product/b1305491#managing-moisture-sensitivity-of-2-fluoro-6-trifluoromethyl-benzylamine>]

---

### Disclaimer & Data Validity:

The information provided in this document is for Research Use Only (RUO) and is strictly not intended for diagnostic or therapeutic procedures. While BenchChem strives to provide accurate protocols, we make no warranties, express or implied, regarding the fitness of this product for every specific experimental setup.

**Technical Support:** The protocols provided are for reference purposes. Unsure if this reagent suits your experiment? [[Contact our Ph.D. Support Team for a compatibility check](#)]

**Need Industrial/Bulk Grade?** [Request Custom Synthesis Quote](#)

## BenchChem

Our mission is to be the trusted global source of essential and advanced chemicals, empowering scientists and researchers to drive progress in science and industry.

### Contact

Address: 3281 E Guasti Rd

Ontario, CA 91761, United States

Phone: (601) 213-4426

Email: [info@benchchem.com](mailto:info@benchchem.com)