

# Application Note: Structural Characterization of 1-(5-Chloro-2-nitrophenyl)piperidine

**Author:** BenchChem Technical Support Team. **Date:** May 2026

## Compound of Interest

Compound Name: 1-(5-Chloro-2-nitrophenyl)piperidine

CAS No.: 53013-43-7

Cat. No.: B1305323

[Get Quote](#)

## Introduction & Chemical Context

**1-(5-Chloro-2-nitrophenyl)piperidine** is a functionalized aryl-amine intermediate, often synthesized via nucleophilic aromatic substitution (

) of 2,4-dichloronitrobenzene or 2,5-dichloronitrobenzene.[1] Its structure features a piperidine ring attached to a nitro-benzene scaffold with a chlorine substituent.[2]

Accurate characterization is critical due to the potential for regioisomeric impurities (e.g., displacement of the incorrect halogen during synthesis). This guide outlines a self-validating analytical workflow combining the isotopic specificity of Mass Spectrometry with the positional resolution of NMR.

## Analytical Strategy Overview

- Mass Spectrometry: Confirms molecular formula via exact mass and validates the presence of chlorine through its distinct isotopic signature (

ratio).[3]

- NMR Spectroscopy: Establishes the regio-chemistry of the aromatic ring (1,2,4-substitution pattern) and confirms the integrity of the piperidine ring.

## Protocol A: Sample Preparation

Safety Warning: Nitro-aromatic compounds can be toxic and potentially explosive under extreme conditions. Handle in a fume hood.

### Materials

- Solvent A (NMR): Deuterated Chloroform ( $CDCl_3$ , 99.8% D) with 0.03% TMS.[1]
- Solvent B (MS): LC-MS grade Methanol (MeOH) and Formic Acid (FA).[1]
- Internal Standard (Optional): Caffeine (for qNMR).

### Procedure

- NMR Sample: Dissolve 5–10 mg of the analyte in 600  $\mu$ L of  $CDCl_3$ . Ensure complete dissolution; if the solution is cloudy, filter through a 0.2  $\mu$ m PTFE syringe filter.
  - Note: If solubility is poor, switch to DMSO- $d_6$ , though this may shift exchangeable protons (none present here, but water peaks may interfere).[1]
- MS Stock Solution: Prepare a 1 mg/mL stock in MeOH.
- MS Working Solution: Dilute stock to 1  $\mu$ g/mL in 50:50 MeOH:Water + 0.1% Formic Acid.

## Protocol B: Mass Spectrometry (LC-MS/MS)[1]

### Rationale

Electrospray Ionization (ESI) in positive mode is selected because the tertiary amine in the piperidine ring is easily protonated. The presence of Chlorine provides a built-in validation check via its natural isotope abundance.

## Instrumental Parameters

- Ionization: ESI (+)
- Capillary Voltage: 3.5 kV[1][2]
- Cone Voltage: 30 V (Adjust to minimize in-source fragmentation)
- Collision Energy: Ramp 15–35 eV for MS/MS fragmentation.[4]

## Data Interpretation & Validation

1. Isotopic Pattern Validation: The molecular ion cluster must exhibit the characteristic 3:1 intensity ratio for

and

. [3][5][6][7]

- $[M+H]^+$  (  
):  $m/z$  241.07[1]
- $[M+H]^+$  (  
):  $m/z$  243.07[1]
- Acceptance Criteria: The intensity of the  $m/z$  243 peak should be  $32\% \pm 5\%$  of the  $m/z$  241 peak.

2. Fragmentation Pathway (MS/MS): Upon collision-induced dissociation (CID), the following transitions validate the structure:

| Fragment Ion (m/z) | Loss Species | Structural Insight                                                                         |
|--------------------|--------------|--------------------------------------------------------------------------------------------|
| 241.07             | Precursor    | Protonated Molecular Ion                                                                   |
| 224.07             | - OH (17 Da) | Ortho Effect: Characteristic of nitro-aromatics with ortho-hydrogens (from piperidine -C). |
| 195.07             | - (46 Da)    | Cleavage of the C-N bond of the nitro group.                                               |
| 84.08              |              | Piperidine ring fragment (Immonium ion).[1]                                                |

## Visualization: MS Fragmentation Logic

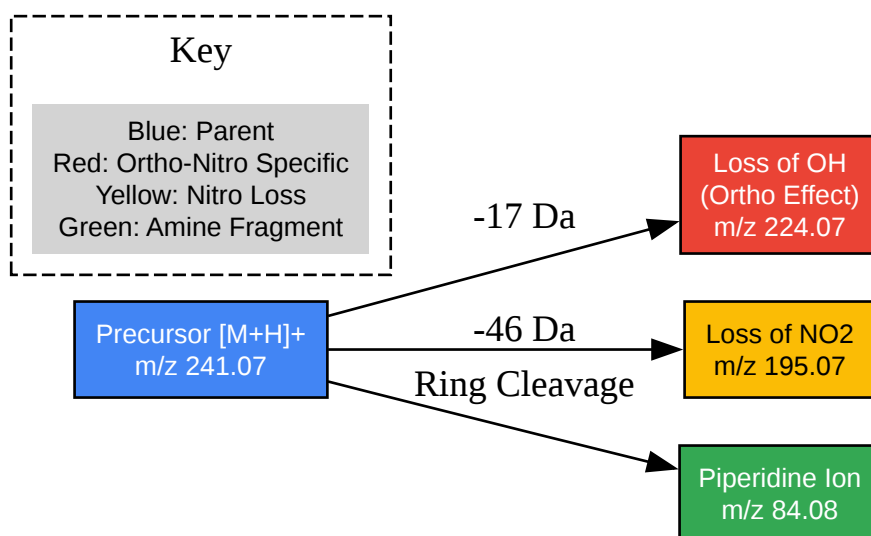

[Click to download full resolution via product page](#)

Figure 1: Proposed ESI-MS/MS fragmentation pathway highlighting the diagnostic "Ortho Effect" loss of OH.

## Protocol C: NMR Spectroscopy

## Rationale

NMR provides the spatial resolution necessary to confirm the substitution pattern on the benzene ring. Specifically, we must distinguish between the 1,2,5-substitution pattern and potential 1,2,4-isomers.

## Experimental Setup

- Frequency: 400 MHz or higher (600 MHz recommended for clear coupling resolution).
- Pulse Sequence: Standard 1D Proton (zg30), COSY, HSQC.
- Scans: 16 (1H), 256 (13C).[1]

## Predicted Spectral Data & Assignment

Solvent:

(  
7.26 ppm)[1]

### 1. Aromatic Region (3 Protons)

The substitution pattern is 1-Piperidiny, 2-Nitro, 5-Chloro.[1]

- H3 (Ortho to  
) : Most deshielded due to the strong electron-withdrawing nitro group.
- H4 (Meta to  
, Ortho to Cl) : Coupled to H3 and H6.
- H6 (Ortho to Piperidine N) : Shielded by the electron-donating nitrogen lone pair.

| Position | Shift (ppm) | Multiplicity | Coupling (Hz) | Assignment Logic                                   |
|----------|-------------|--------------|---------------|----------------------------------------------------|
| H-3      | 7.80 – 7.90 | Doublet (d)  |               | Ortho to (Deshielded)                              |
| H-4      | 6.90 – 7.00 | dd           |               | Vicinal to H3, Meta to H6                          |
| H-6      | 7.05 – 7.15 | Doublet (d)  |               | Ortho to Piperidine (Shielded), Meta coupling only |

Note: H6 appears as a doublet with a small coupling constant because its para position (C3) is blocked, and its ortho position (C1) is blocked.<sup>[1]</sup> It only couples meta to H4.

## 2. Aliphatic Region (Piperidine)

The piperidine ring is attached to an electron-withdrawing aromatic system, shifting the -protons downfield compared to free piperidine.

| Position         | Shift (ppm) | Integral | Multiplicity    | Assignment                  |
|------------------|-------------|----------|-----------------|-----------------------------|
| -CH <sub>2</sub> | 3.00 – 3.15 | 4H       | Broad Multiplet | Adjacent to Nitrogen (N-Ar) |
| -CH <sub>2</sub> | 1.70 – 1.80 | 4H       | Multiplet       | Beta to Nitrogen            |
| -CH <sub>2</sub> | 1.55 – 1.65 | 2H       | Multiplet       | Farthest from Nitrogen      |

## Visualization: Analytical Workflow

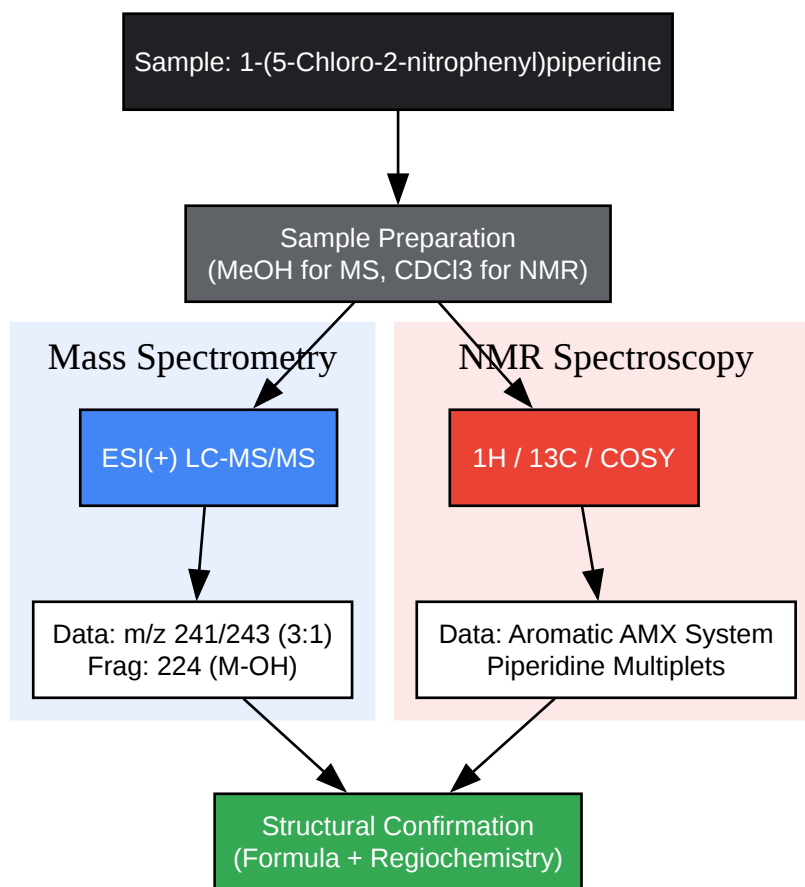

[Click to download full resolution via product page](#)

Figure 2: Integrated analytical workflow for structural confirmation.

## Quality Control & System Suitability

To ensure data integrity (E-E-A-T), perform the following checks before final analysis:

- NMR Line Shape: The chloroform residual peak should have a linewidth at half-height Hz. If not, re-shim the magnet.<sup>[1]</sup>
- MS Calibration: Calibrate the TOF/Orbitrap using sodium formate or a standard tuning mix to ensure mass accuracy ppm.
- Solvent Blank: Run a solvent blank to ensure no carryover of piperidine derivatives from previous runs.

## References

- Silverstein, R. M., Webster, F. X., & Kiemle, D. J. (2005).[1] Spectrometric Identification of Organic Compounds. 7th Edition. John Wiley & Sons.[4] (Standard text for NMR coupling constants and MS fragmentation).
- National Institute of Advanced Industrial Science and Technology (AIST). (n.d.). Spectral Database for Organic Compounds (SDBS). Retrieved from [Link] (Reference for nitro-aniline and piperidine shifts).
- McLafferty, F. W., & Tureček, F. (1993).[1] Interpretation of Mass Spectra. 4th Edition. University Science Books. (Source for Chlorine isotope patterns and Ortho effects).
- PubChem Database. (2023). **1-(5-Chloro-2-nitrophenyl)piperidine** Compound Summary. National Library of Medicine. Retrieved from [Link]

### Need Custom Synthesis?

BenchChem offers custom synthesis for rare earth carbides and specific isotopic labeling.

Email: [info@benchchem.com](mailto:info@benchchem.com) or [Request Quote Online](#).

## Sources

- 1. [rsc.org](https://www.rsc.org) [rsc.org]
- 2. 1-(2-Chloroethyl)piperidine hydrochloride(2008-75-5) <sup>1</sup>H NMR spectrum [chemicalbook.com]
- 3. [scholar.ulethbridge.ca](https://scholar.ulethbridge.ca) [scholar.ulethbridge.ca]
- 4. NP-MRD: <sup>1</sup>H NMR Spectrum (1D, 400 MHz, H<sub>2</sub>O, predicted) (NP0161565) [np-mrd.org]
- 5. Isotopes in Mass Spectrometry - Chemistry Steps [chemistrysteps.com]
- 6. [chemguide.co.uk](https://www.chemguide.co.uk) [chemguide.co.uk]
- 7. [chem.libretexts.org](https://chem.libretexts.org) [chem.libretexts.org]
- To cite this document: BenchChem. [Application Note: Structural Characterization of 1-(5-Chloro-2-nitrophenyl)piperidine]. BenchChem, [2026]. [Online PDF]. Available at:

[\[https://www.benchchem.com/product/b1305323/docs#application-note-structural-characterization-of-1-5-chloro-2-nitrophenyl-piperidine\]](https://www.benchchem.com/product/b1305323/docs#application-note-structural-characterization-of-1-5-chloro-2-nitrophenyl-piperidine)

### Disclaimer & Data Validity:

The information provided in this document is for Research Use Only (RUO) and is strictly not intended for diagnostic or therapeutic procedures. While BenchChem strives to provide accurate protocols, we make no warranties, express or implied, regarding the fitness of this product for every specific experimental setup.

**Technical Support:** The protocols provided are for reference purposes. Unsure if this reagent suits your experiment?

**Need Industrial/Bulk Grade?** [Request Custom Synthesis Quote](#)

## BenchChem

Our mission is to be the trusted global source of essential and advanced chemicals, empowering scientists and researchers to drive progress in science and industry.

### Contact

Address: 3281 E Guasti Rd  
Ontario, CA 91761, United States  
Phone: (601) 213-4426  
Email: [info@benchchem.com](mailto:info@benchchem.com)

[Contact our Ph.D. Support Team for a compatibility check](#)