

Application Note: Scalable Asymmetric Synthesis of Chiral Benzofuran Propanoic Acid Derivatives

Author: BenchChem Technical Support Team. **Date:** April 2026

Compound of Interest

Compound Name: (3S)-3-amino-3-(1-benzofuran-2-yl)propanoic acid

Cat. No.: B13048478

[Get Quote](#)

Abstract

Chiral 3-(benzofuran-2-yl)propanoic acid derivatives represent a critical pharmacophore in modern drug development, particularly for G-protein-coupled receptor 40 (GPR40) agonists (e.g., Fasiglifam/TAK-875 analogs) and PPAR modulators used in metabolic disorders.[1] The transition from medicinal chemistry (mg-scale) to process chemistry (kg-scale) requires a shift from chiral resolution to asymmetric catalysis. This guide details a scalable, self-validating workflow for synthesizing these moieties with >98% enantiomeric excess (ee), comparing Asymmetric Hydrogenation (AH) and Biocatalytic Ene-Reduction.

Introduction & Strategic Route Selection

The synthesis of chiral benzofuran propanoic acids hinges on establishing the stereocenter at the

-position relative to the carboxyl group. While early-phase discovery often relies on chiral HPLC separation or diastereomeric salt resolution, these methods are attrition-heavy (max 50% yield)

and unsuitable for multi-kilogram production.

The Scalability Pivot

To achieve scalability, we employ a "Construct-then-Reduce" strategy:

- Core Assembly: Robust formation of the benzofuran ring.
- Olefin Installation: Knoevenagel or Horner-Wadsworth-Emmons (HWE) condensation to generate the achiral acrylic acid precursor.
- Asymmetric Induction: Catalytic reduction of the olefin to set the chiral center.

Route Comparison Table

Feature	Method A: Asymmetric Hydrogenation (Ru/Rh)	Method B: Biocatalytic Ene-Reduction
Scalability	High (Ton-scale proven)	Medium-High (Requires fermentation/enzyme supply)
Cost	High (Precious metal catalysts)	Low (Renewable biocatalysts)
Purity (ee)	95-99% (Ligand dependent)	>99% (Strict enzyme specificity)
Conditions	High Pressure (10-50 bar)	Ambient Temp/Pressure, Aqueous buffer
Cleanup	Metal scavenging required	Protein precipitation/filtration

Retrosynthetic Analysis & Workflow

The following diagram outlines the logic flow from the target chiral acid back to the raw materials, highlighting the critical decision point at the asymmetric step.

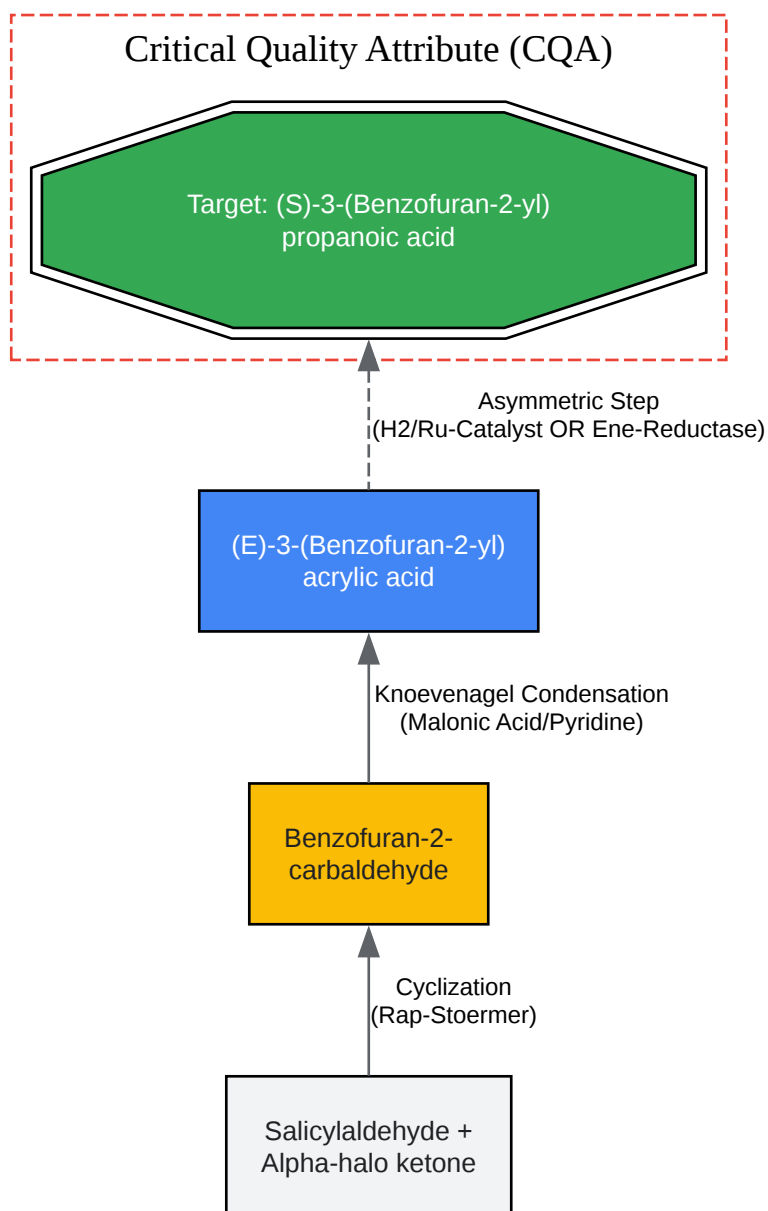

[Click to download full resolution via product page](#)

Figure 1: Retrosynthetic strategy emphasizing the late-stage installation of chirality via asymmetric reduction of the acrylic acid intermediate.

Protocol 1: Synthesis of Precursor (E)-3-(Benzofuran-2-yl)acrylic acid

Before addressing chirality, the unsaturated precursor must be synthesized with high geometric purity (

-isomer), as the

-isomer can inhibit catalytic cycles or reduce enantioselectivity.

Reagents & Equipment[2]

- Substrate: Benzofuran-2-carbaldehyde (1.0 equiv)
- Reagent: Malonic acid (1.2 equiv)
- Base/Solvent: Pyridine (5.0 equiv), Piperidine (0.1 equiv cat.)
- Equipment: 5L Jacketed Reactor, Reflux Condenser.

Step-by-Step Methodology

- Charge: Load benzofuran-2-carbaldehyde and malonic acid into the reactor under .
- Solvation: Add pyridine followed by catalytic piperidine.
- Reaction: Heat to 90°C for 4–6 hours. Monitor by HPLC for disappearance of aldehyde (<0.5%).
 - Mechanism:[2][3][4][5] Knoevenagel condensation followed by thermal decarboxylation.
- Quench: Cool to 20°C. Slowly add concentrated HCl/Ice mixture until pH < 2.
 - Critical: The product precipitates as a solid. Rapid acidification ensures fine particle size.
- Isolation: Filter the slurry. Wash the cake with water (vol) to remove pyridinium salts.
- Purification: Recrystallize from Ethanol/Water (9:1) to ensure removal of any -isomer.
- Drying: Vacuum oven at 45°C.

Yield Target: >85% | Purity: >98% (HPLC), >99:1 E/Z ratio.

Protocol 2: Asymmetric Hydrogenation (Chemical Route)

This is the industry-standard method for scaling GPR40 agonists (e.g., TAK-875 intermediates). The choice of ligand is critical; Ru-SEGPHOS or Ru-H8-BINAP complexes are preferred for their rigidity and electronic properties.

Mechanistic Insight

Ruthenium(II) carboxylate complexes coordinate with the substrate's carboxylate group. The rigidity of the biaryl ligand (BINAP/SEGPHOS) forces the incoming molecule to attack from a specific face of the olefin, inducing chirality.

Reagents & Equipment[2]

- Substrate: (E)-3-(Benzofuran-2-yl)acrylic acid (from Protocol 1).
- Catalyst:

or

(S/C ratio 1:1000 to 1:5000).
- Solvent: Degassed Methanol or Trifluoroethanol (TFE).
- Equipment: High-Pressure Hydrogenation Autoclave (Hastelloy or Stainless Steel).

Step-by-Step Methodology

- Inertion (Critical): Purge the autoclave 3x with

to remove all oxygen (catalyst poison).
- Catalyst Prep: In a glovebox, dissolve the Ru-catalyst in degassed methanol.
- Loading: Transfer the substrate solution (in MeOH) and catalyst solution to the autoclave via cannula/suction.

- Pressurization: Charge to 3.0 MPa (30 bar).
- Reaction: Heat to 50°C and stir at high RPM (800+) to eliminate mass transfer limitations.
 - Time: 12–24 hours.
- Workup: Vent
 - . Concentrate the solvent.
- Metal Scavenging: Dissolve residue in EtOAc. Add SiliaMetS® Thiol or charcoal to remove residual Ru (Target <10 ppm). Filter through Celite.
- Crystallization (Enrichment): If ee is <99%, form a salt with (S)-1-phenylethylamine in Isopropanol. Cool slowly to crystallize the diastereomeric salt, then break the salt with 1N HCl.

Performance Metrics:

- Conversion: >99%
- ee: >96% (crude), >99% (after crystallization)

Protocol 3: Biocatalytic Ene-Reduction (Green Route)

For labs prioritizing green chemistry or lacking high-pressure infrastructure, Old Yellow Enzymes (OYEs) or Ene-Reductases (EREDs) offer a mild alternative.

Reagents

- Enzyme: Recombinant Ene-Reductase (e.g., OYE1 or commercial kits like Codexis/Evoxx panels).
- Cofactor Recycling: Glucose + Glucose Dehydrogenase (GDH) + NADP+.
- Buffer: Potassium Phosphate (pH 7.0).

Step-by-Step Methodology

- Buffer Prep: Prepare 100 mM KPi buffer (pH 7.0) containing 1% Glucose.
- Substrate Addition: Dissolve the acrylic acid substrate in DMSO (5% v/v final concentration) and add to buffer.
- Initiation: Add NADP⁺ (0.1 mM), GDH, and the Ene-Reductase.
- Incubation: Shake at 30°C, 200 RPM for 24 hours.
- Extraction: Acidify to pH 2 with HCl. Extract with MTBE or EtOAc.
- Isolation: Evaporate solvent.

Note: Biocatalysis often yields >99% ee directly, eliminating the need for salt crystallization.

Analytical Validation (HPLC Method)

To validate the protocols, a robust chiral HPLC method is required.

- Column: Chiralpak AD-H or OD-H (4.6 mm, 5 μm).
- Mobile Phase: n-Hexane / Isopropanol / TFA (90 : 10 : 0.1).
- Flow Rate: 1.0 mL/min.
- Detection: UV @ 254 nm (Benzofuran absorption).
- Retention Times (Typical):
 - (R)-Isomer: ~8.5 min
 - (S)-Isomer: ~10.2 min
 - Precursor (Acrylic acid): ~15.0 min

Process Troubleshooting & Logic

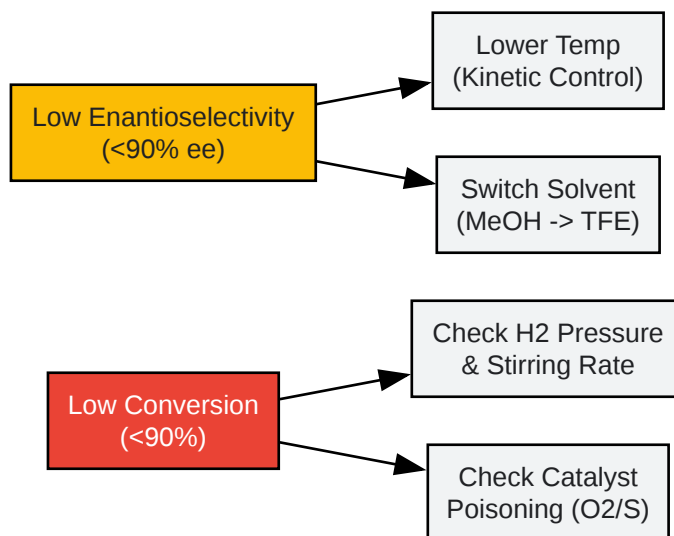

[Click to download full resolution via product page](#)

Figure 2: Decision tree for troubleshooting common issues in asymmetric hydrogenation.

References

- Takeda Pharmaceutical Company. "Process Research and Development of Fasiglifam (TAK-875): A GPR40 Agonist for the Treatment of Type 2 Diabetes." Organic Process Research & Development, 2014.
- Noyori, R., et al.
-Aryl Acrylic Acids." Journal of Organic Chemistry, 1987.
- Giacomelli, G., et al. "A Facile Approach to the Synthesis of Chiral 2-Substituted Benzofurans." [2] Journal of Organic Chemistry, 2007. [2]
- Pfaltz, A., et al. "Asymmetric hydrogenation of furans and benzofurans with iridium-pyridine-phosphinite catalysts." [6] Chemistry - A European Journal, 2015.
- Nestl, B.M., et al. "Enantioselective Enzymatic Reduction of Acrylic Acids." Organic Letters, 2020. [7]

Need Custom Synthesis?

BenchChem offers custom synthesis for rare earth carbides and specific isotopic labeling.

Email: info@benchchem.com or [Request Quote Online](#).

Sources

- [1. researchgate.net \[researchgate.net\]](https://www.researchgate.net)
- [2. organic-chemistry.org \[organic-chemistry.org\]](https://www.organic-chemistry.org)
- [3. mdpi.com \[mdpi.com\]](https://www.mdpi.com)
- [4. Selective synthesis of 3-formylbenzofuran and 3-acylbenzofuran using a chalcone rearrangement strategy - PMC \[pmc.ncbi.nlm.nih.gov\]](#)
- [5. lac.dicp.ac.cn \[lac.dicp.ac.cn\]](https://www.lac.dicp.ac.cn)
- [6. Asymmetric hydrogenation of furans and benzofurans with iridium-pyridine-phosphinite catalysts - PubMed \[pubmed.ncbi.nlm.nih.gov\]](#)
- [7. Enantioselective Enzymatic Reduction of Acrylic Acids - PubMed \[pubmed.ncbi.nlm.nih.gov\]](#)
- To cite this document: BenchChem. [Application Note: Scalable Asymmetric Synthesis of Chiral Benzofuran Propanoic Acid Derivatives]. BenchChem, [2026]. [Online PDF]. Available at: [<https://www.benchchem.com/product/b13048478/docs#application-note-scalable-asymmetric-synthesis-of-chiral-benzofuran-propanoic-acid-derivatives>]

Disclaimer & Data Validity:

The information provided in this document is for Research Use Only (RUO) and is strictly not intended for diagnostic or therapeutic procedures. While BenchChem strives to provide accurate protocols, we make no warranties, express or implied, regarding the fitness of this product for every specific experimental setup.

Technical Support: The protocols provided are for reference purposes. Unsure if this reagent suits your experiment?

Need Industrial/Bulk Grade? [Request Custom Synthesis Quote](#)

BenchChem

Our mission is to be the trusted global source of essential and advanced chemicals, empowering scientists and researchers to drive progress in science and industry.

Contact

Address: 3281 E Guasti Rd

Ontario, CA 91761, United States

Phone: (601) 213-4426

Email: info@benchchem.com

[Contact our Ph.D. Support Team for a compatibility check](#)