

# Physical and chemical properties of 1-(4-Fluoro-3-methoxyphenyl)ethanone

**Author:** BenchChem Technical Support Team. **Date:** January 2026

## Compound of Interest

Compound Name: 1-(4-Fluoro-3-methoxyphenyl)ethanone

Cat. No.: B1304783

[Get Quote](#)

## An In-Depth Technical Guide to 1-(4-Fluoro-3-methoxyphenyl)ethanone

For Researchers, Scientists, and Drug Development Professionals

### Introduction

**1-(4-Fluoro-3-methoxyphenyl)ethanone**, a substituted acetophenone, serves as a valuable building block in organic synthesis, particularly in the development of novel pharmaceutical agents. Its unique substitution pattern, featuring a fluorine atom and a methoxy group on the phenyl ring, imparts distinct physicochemical properties that are of significant interest in medicinal chemistry. This guide provides a comprehensive overview of the physical and chemical properties, experimental protocols for its synthesis and analysis, and potential biological activities of this compound.

### Physicochemical Properties

The properties of **1-(4-Fluoro-3-methoxyphenyl)ethanone** are summarized below. Data is compiled from various sources and includes both experimental and predicted values.

### Identifiers and General Properties

Property	Value	Reference
IUPAC Name	1-(4-Fluoro-3-methoxyphenyl)ethanone	N/A
CAS Number	64287-19-0	N/A
Molecular Formula	C <sub>9</sub> H <sub>9</sub> FO <sub>2</sub>	N/A
Molecular Weight	168.17 g/mol	N/A
Appearance	White to off-white crystalline solid	N/A

## Physical Properties

Property	Value	Reference
Melting Point	49-52 °C	N/A
Boiling Point	124 °C at 10 mmHg	N/A
Solubility	Soluble in organic solvents such as methanol, ethanol, and dichloromethane. Insoluble in water.	N/A

## Spectroscopic Data

Technique	Data
<sup>1</sup> H NMR (CDCl <sub>3</sub> , 400 MHz)	δ (ppm): 7.61 (dd, J=8.4, 2.0 Hz, 1H), 7.55 (dd, J=10.8, 2.0 Hz, 1H), 7.18 (t, J=8.4 Hz, 1H), 3.95 (s, 3H), 2.58 (s, 3H)
<sup>13</sup> C NMR (CDCl <sub>3</sub> , 100 MHz)	δ (ppm): 196.5, 157.8 (d, J=252.0 Hz), 147.9 (d, J=11.0 Hz), 125.8, 124.9 (d, J=3.0 Hz), 115.8 (d, J=22.0 Hz), 112.9, 56.4, 26.5
Infrared (IR)	ν (cm <sup>-1</sup> ): 1678 (C=O), 1615, 1515 (C=C, aromatic), 1275 (C-O), 1230 (C-F)
Mass Spectrometry (MS)	m/z: 168.06 (M <sup>+</sup> ), 153.04, 125.04, 97.03

## Experimental Protocols

### Synthesis: Friedel-Crafts Acylation of 2-Fluoroanisole

This protocol describes a general method for the synthesis of **1-(4-Fluoro-3-methoxyphenyl)ethanone** via Friedel-Crafts acylation of 2-fluoroanisole.

Materials:

- 2-Fluoroanisole
- Acetyl chloride or acetic anhydride
- Anhydrous aluminum chloride (AlCl<sub>3</sub>)
- Dichloromethane (DCM), anhydrous
- Hydrochloric acid (HCl), concentrated
- Sodium bicarbonate (NaHCO<sub>3</sub>), saturated solution
- Brine
- Anhydrous magnesium sulfate (MgSO<sub>4</sub>) or sodium sulfate (Na<sub>2</sub>SO<sub>4</sub>)

- Ice

#### Procedure:

- In a flame-dried, three-necked round-bottom flask equipped with a magnetic stirrer, a dropping funnel, and a nitrogen inlet, suspend anhydrous aluminum chloride (1.1 eq.) in anhydrous dichloromethane under a nitrogen atmosphere.
- Cool the suspension to 0 °C in an ice bath.
- Add acetyl chloride (1.0 eq.) dropwise to the stirred suspension via the dropping funnel.
- After the addition is complete, add a solution of 2-fluoroanisole (1.0 eq.) in anhydrous dichloromethane dropwise to the reaction mixture.
- Allow the reaction to stir at 0 °C for 1 hour and then warm to room temperature, monitoring the reaction progress by Thin Layer Chromatography (TLC).
- Upon completion, carefully pour the reaction mixture into a beaker containing crushed ice and concentrated HCl.
- Transfer the mixture to a separatory funnel and separate the organic layer.
- Extract the aqueous layer with dichloromethane.
- Combine the organic layers and wash sequentially with water, saturated sodium bicarbonate solution, and brine.
- Dry the organic layer over anhydrous magnesium sulfate or sodium sulfate, filter, and concentrate under reduced pressure to yield the crude product.
- Purify the crude product by recrystallization from a suitable solvent system (e.g., ethanol/water or hexanes/ethyl acetate) or by column chromatography on silica gel.

#### Experimental Workflow for Synthesis

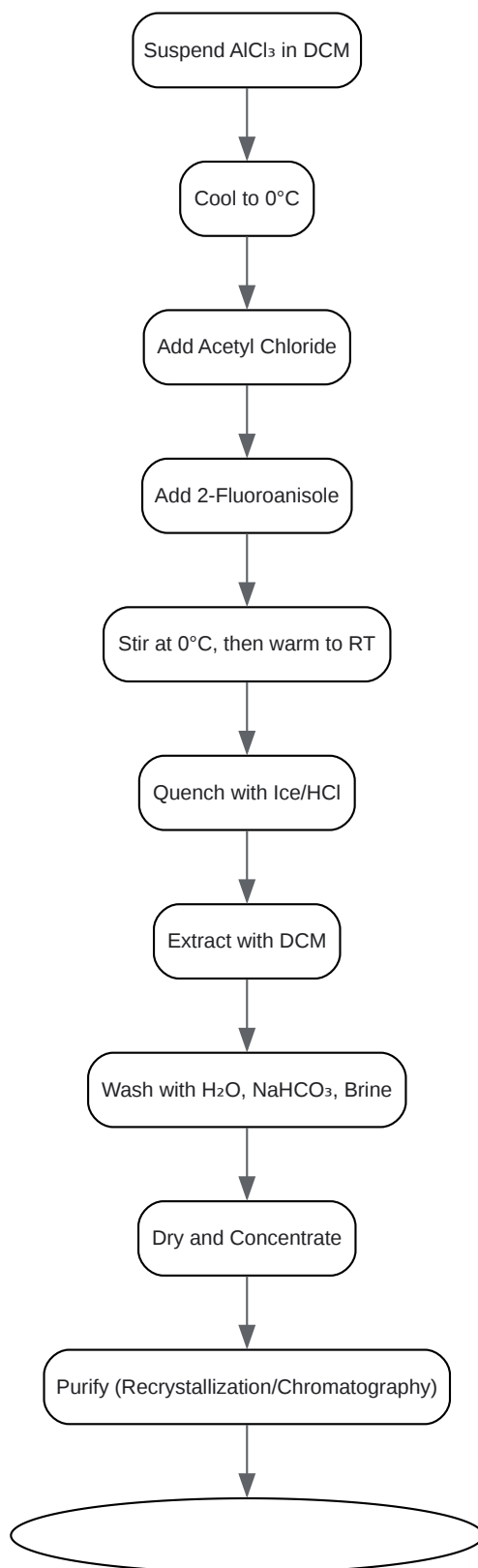

[Click to download full resolution via product page](#)

A flowchart of the synthesis of **1-(4-Fluoro-3-methoxyphenyl)ethanone**.

## Analytical Methods

### Instrumentation:

- Gas chromatograph coupled to a mass spectrometer.
- Column: A non-polar or medium-polarity capillary column (e.g., HP-5MS, DB-5).

### GC Conditions:

- Injector Temperature: 250 °C
- Oven Program: Initial temperature of 100 °C, hold for 2 minutes, then ramp to 250 °C at a rate of 10 °C/min, and hold for 5 minutes.
- Carrier Gas: Helium at a constant flow of 1 mL/min.

### MS Conditions:

- Ionization Mode: Electron Impact (EI) at 70 eV.
- Source Temperature: 230 °C.
- Quadrupole Temperature: 150 °C.
- Scan Range: m/z 40-400.

### Sample Preparation:

- Dissolve a small amount of the sample in a suitable volatile solvent (e.g., dichloromethane or ethyl acetate) to a concentration of approximately 1 mg/mL.

### Instrumentation:

- NMR spectrometer (e.g., 400 MHz).

### Sample Preparation:

- Dissolve approximately 10-20 mg of the sample in 0.6-0.7 mL of deuterated chloroform ( $\text{CDCl}_3$ ).

Acquisition Parameters ( $^1\text{H}$  NMR):

- Pulse Program: Standard single-pulse experiment.
- Number of Scans: 16.
- Relaxation Delay: 1.0 s.

Acquisition Parameters ( $^{13}\text{C}$  NMR):

- Pulse Program: Proton-decoupled experiment.
- Number of Scans: 1024.
- Relaxation Delay: 2.0 s.

## Potential Biological Activity and Signaling Pathway Involvement

While direct studies on the biological activity of **1-(4-Fluoro-3-methoxyphenyl)ethanone** are limited in publicly available literature, research on structurally similar compounds provides valuable insights into its potential pharmacological effects.

A closely related compound, 1-(5-bromo-2-hydroxy-4-methoxyphenyl)ethanone, has been shown to suppress pro-inflammatory responses in activated microglia by blocking the Nuclear Factor-kappa B (NF- $\kappa$ B) and Mitogen-Activated Protein Kinase (MAPK) signaling pathways. This suggests that **1-(4-Fluoro-3-methoxyphenyl)ethanone** may possess similar anti-inflammatory properties.

## Postulated Mechanism of Action: Inhibition of NF- $\kappa$ B and MAPK Signaling

Inflammatory stimuli, such as lipopolysaccharide (LPS), can activate cell surface receptors (e.g., Toll-like receptor 4), triggering downstream signaling cascades that lead to the activation

of NF- $\kappa$ B and MAPKs (including p38, JNK, and ERK).

- **NF- $\kappa$ B Pathway:** In its inactive state, NF- $\kappa$ B is sequestered in the cytoplasm by inhibitor of  $\kappa$ B (I $\kappa$ B) proteins. Upon stimulation, the I $\kappa$ B kinase (IKK) complex phosphorylates I $\kappa$ B $\alpha$ , leading to its ubiquitination and subsequent degradation by the proteasome. This allows the NF- $\kappa$ B p65/p50 heterodimer to translocate to the nucleus, where it induces the transcription of pro-inflammatory genes, such as iNOS, COX-2, TNF- $\alpha$ , and various interleukins.
- **MAPK Pathway:** The MAPK pathways are also activated by inflammatory stimuli and play a crucial role in regulating the expression of inflammatory mediators.

It is hypothesized that **1-(4-Fluoro-3-methoxyphenyl)ethanone** may inhibit the phosphorylation of key signaling molecules in these pathways, thereby preventing the nuclear translocation of NF- $\kappa$ B and the activation of MAPKs. This would lead to a reduction in the production of pro-inflammatory mediators.

Hypothesized Signaling Pathway Inhibition



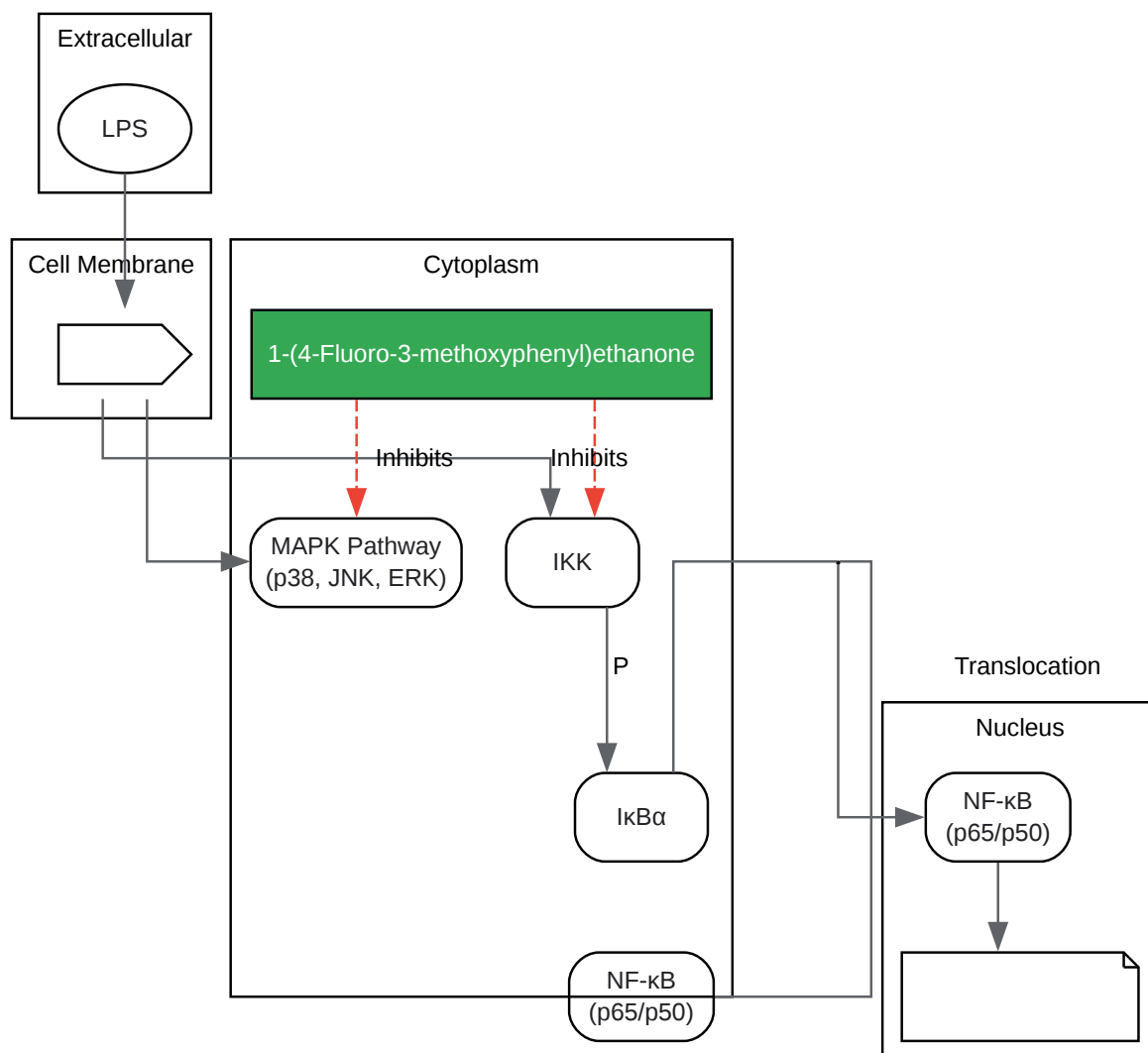

[Click to download full resolution via product page](#)

Postulated inhibition of NF-κB and MAPK pathways by the compound.

## Conclusion

**1-(4-Fluoro-3-methoxyphenyl)ethanone** is a compound with significant potential in the field of drug discovery and development. Its synthesis is achievable through established organic chemistry reactions, and its purity and identity can be confirmed using standard analytical techniques. Based on the activity of structurally related molecules, it is a promising candidate for further investigation as an anti-inflammatory agent. The detailed protocols and hypothesized mechanism of action presented in this guide provide a solid foundation for researchers to

explore the therapeutic potential of this and similar compounds. Further studies are warranted to elucidate its precise biological activities and to validate its effects on the NF- $\kappa$ B and MAPK signaling pathways.

- To cite this document: BenchChem. [Physical and chemical properties of 1-(4-Fluoro-3-methoxyphenyl)ethanone]. BenchChem, [2026]. [Online PDF]. Available at: [<https://www.benchchem.com/product/b1304783#physical-and-chemical-properties-of-1-4-fluoro-3-methoxyphenyl-ethanone>]

---

### Disclaimer & Data Validity:

The information provided in this document is for Research Use Only (RUO) and is strictly not intended for diagnostic or therapeutic procedures. While BenchChem strives to provide accurate protocols, we make no warranties, express or implied, regarding the fitness of this product for every specific experimental setup.

**Technical Support:** The protocols provided are for reference purposes. Unsure if this reagent suits your experiment? [[Contact our Ph.D. Support Team for a compatibility check](#)]

**Need Industrial/Bulk Grade?** [Request Custom Synthesis Quote](#)

## BenchChem

Our mission is to be the trusted global source of essential and advanced chemicals, empowering scientists and researchers to drive progress in science and industry.

### Contact

Address: 3281 E Guasti Rd  
Ontario, CA 91761, United States  
Phone: (601) 213-4426  
Email: [info@benchchem.com](mailto:info@benchchem.com)