

Technical Support Center: Synthesis of 4-Chloro-3',4'-difluorobenzophenone

Author: BenchChem Technical Support Team. **Date:** April 2026

Compound of Interest

| | |
|----------------|-------------------------------------|
| Compound Name: | 4-Chloro-3',4'-difluorobenzophenone |
| CAS No.: | 844885-01-4 |
| Cat. No.: | B1302634 |

[Get Quote](#)

Welcome to the technical support guide for the synthesis of **4-Chloro-3',4'-difluorobenzophenone**. This resource is designed for researchers, chemists, and drug development professionals to navigate the common challenges and optimize the yield and purity of this important synthetic intermediate. As Senior Application Scientists, we have compiled field-proven insights and troubleshooting strategies to support your experimental work.

Frequently Asked Questions (FAQs)

Q1: What is the most common and industrially viable method for synthesizing 4-Chloro-3',4'-difluorobenzophenone?

The most prevalent method for synthesizing **4-Chloro-3',4'-difluorobenzophenone** is the Friedel-Crafts acylation.^[1] This classic electrophilic aromatic substitution reaction involves reacting 1,2-difluorobenzene with 4-chlorobenzoyl chloride in the presence of a strong Lewis acid catalyst, most commonly anhydrous aluminum chloride (AlCl₃).^{[2][3]} The reaction is valued

for its efficiency in forming the carbon-carbon bond between the aromatic rings and the carbonyl group.

Q2: Can you explain the fundamental mechanism of this Friedel-Crafts acylation reaction?

Certainly. The reaction proceeds via a well-established three-step electrophilic aromatic substitution mechanism:

- **Formation of the Electrophile:** The Lewis acid catalyst (e.g., AlCl_3) coordinates to the chlorine atom of the 4-chlorobenzoyl chloride. This interaction polarizes the carbon-chlorine bond, leading to the formation of a highly reactive and resonance-stabilized acylium ion ($\text{R-C}\equiv\text{O}^+$).
[4][5]
- **Electrophilic Attack:** The electron-rich π -system of the 1,2-difluorobenzene ring acts as a nucleophile, attacking the electrophilic acylium ion. This step forms a new carbon-carbon bond and creates a resonance-stabilized carbocation intermediate known as an arenium ion or sigma complex. The aromaticity of the ring is temporarily lost.[4]
- **Deprotonation and Regeneration:** A weak base, typically the $[\text{AlCl}_4]^-$ complex, removes a proton from the carbon atom bearing the new acyl group. This restores the aromaticity of the difluorinated ring, yielding the final product, **4-Chloro-3',4'-difluorobenzophenone**. The process also regenerates the Lewis acid catalyst and produces hydrogen chloride (HCl) as a byproduct.[5][6]

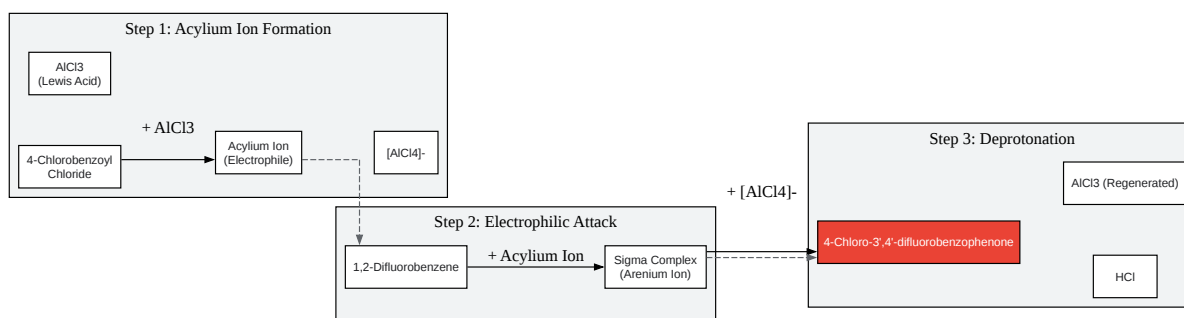

[Click to download full resolution via product page](#)

Caption: Friedel-Crafts Acylation Mechanism.

Troubleshooting Guide: Improving Yield and Purity

This section addresses specific issues that may arise during the synthesis, providing causal explanations and actionable solutions.

Q3: My reaction yield is consistently below 50%. What are the primary factors I should investigate?

Low yield is a common problem that can often be traced to a few critical parameters. A systematic approach to troubleshooting is recommended.

Possible Causes & Solutions:

- **Catalyst Quality and Stoichiometry:** Anhydrous aluminum chloride is extremely hygroscopic. Moisture will hydrolyze AlCl₃, rendering it inactive. Furthermore, the ketone product forms a

stable complex with AlCl_3 , effectively sequestering it.[7] Therefore, a stoichiometric amount (at least 1.0 to 1.1 equivalents) of the catalyst is required relative to the acylating agent.[7][8]

- Solution: Always use freshly opened, high-purity anhydrous AlCl_3 . Perform the reaction under strictly anhydrous conditions (e.g., under a nitrogen or argon atmosphere) using oven-dried glassware. Ensure you are using a stoichiometric quantity of the catalyst.
- Reaction Temperature: Friedel-Crafts acylations are exothermic. If the temperature is too low, the reaction rate will be impractically slow. If it's too high, it can promote side reactions and potential degradation of starting materials or product.
 - Solution: Initiate the reaction at a low temperature (0-5 °C) during the addition of reagents to control the initial exotherm.[9] Then, allow the reaction to warm to room temperature or gently heat it as needed to drive it to completion. Monitor progress using Thin Layer Chromatography (TLC).
- Purity of Reagents: The purity of 1,2-difluorobenzene and 4-chlorobenzoyl chloride is paramount. Impurities in the starting materials can interfere with the reaction or lead to difficult-to-separate byproducts.
 - Solution: Use reagents of the highest available purity. If necessary, purify the 1,2-difluorobenzene by distillation and the 4-chlorobenzoyl chloride by distillation under reduced pressure.

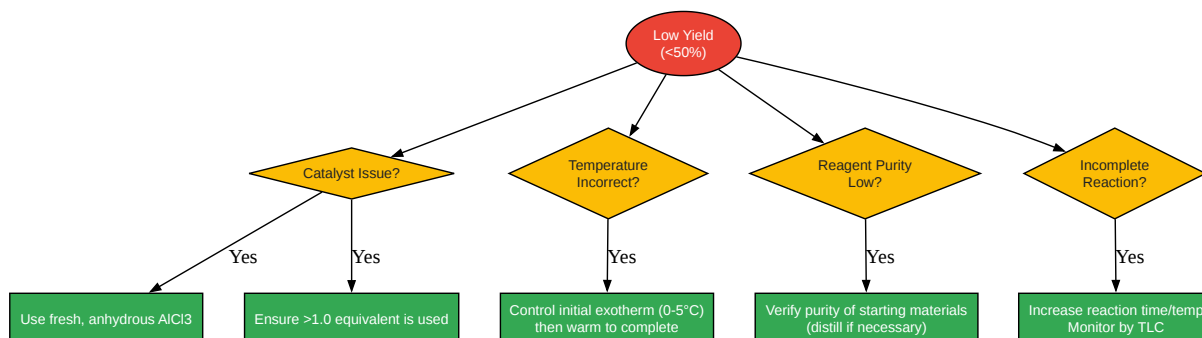

[Click to download full resolution via product page](#)

Caption: Troubleshooting Workflow for Low Yield.

Q4: I am observing isomeric impurities in my product. How can I improve the regioselectivity for the desired 3',4'-difluoro isomer?

Regioselectivity is governed by the directing effects of the substituents on the aromatic ring. In 1,2-difluorobenzene, both fluorine atoms are ortho-, para-directing and deactivating. The acylation should preferentially occur at the C4 position, which is para to one fluorine and meta to the other, due to reduced steric hindrance compared to the ortho positions.

Factors Influencing Regioselectivity:

| Parameter | Effect on Selectivity | Rationale |
|-----------------|---|--|
| Temperature | Lower temperatures generally favor the para-isomer. | The transition state leading to the para product is sterically less hindered and thus lower in energy. At higher temperatures, more energy is available to overcome the activation barrier for ortho-substitution. |
| Solvent | Non-polar solvents (e.g., dichloroethane, carbon disulfide) can enhance para-selectivity. | Solvents can influence the effective size of the electrophile complex. Less polar solvents may lead to a bulkier complex, further disfavoring attack at the sterically crowded ortho position. |
| Catalyst Choice | Bulkier Lewis acids may increase para-selectivity. | While AlCl_3 is standard, exploring bulkier catalysts like FeCl_3 or TiCl_4 could potentially increase steric hindrance for ortho-attack, though optimization would be required.[2] |

Solution: To maximize the yield of the **4-Chloro-3',4'-difluorobenzophenone** isomer, conduct the reaction at the lowest practical temperature that allows for a reasonable reaction rate (e.g., start at 0°C and allow to slowly warm to room temperature). Use a non-polar solvent like dichloroethane.

Q5: The workup and purification process is proving difficult. What is a reliable protocol for isolating a high-purity product?

A careful workup is crucial for removing the catalyst and any unreacted starting materials before final purification.

Recommended Purification Protocol:

- **Quenching:** Once the reaction is complete (as determined by TLC), cool the reaction mixture in an ice bath. Slowly and carefully pour the mixture onto crushed ice, often with the addition of concentrated HCl. This hydrolyzes the aluminum chloride catalyst and breaks up the product-catalyst complex. Caution: This process is highly exothermic and releases HCl gas. Perform in a well-ventilated fume hood.
- **Extraction:** Transfer the quenched mixture to a separatory funnel. Extract the aqueous layer with a suitable organic solvent (e.g., dichloromethane or ethyl acetate). Combine the organic layers.
- **Washing:** Wash the combined organic layers sequentially with dilute HCl, water, a saturated sodium bicarbonate solution (to neutralize any remaining acid), and finally with brine.
- **Drying and Concentration:** Dry the organic layer over an anhydrous drying agent (e.g., MgSO₄ or Na₂SO₄), filter, and remove the solvent under reduced pressure to obtain the crude product.
- **Recrystallization:** Recrystallization is the most effective method for final purification. The crude solid can be dissolved in a minimum amount of a hot solvent, such as ethanol or a mixture of hexane and ethyl acetate. Upon slow cooling, the desired product should crystallize out, leaving impurities behind in the mother liquor. Filter the crystals and dry them under vacuum.^[9]

Experimental Protocols

Protocol 1: Synthesis of 4-Chloro-3',4'-difluorobenzophenone

This protocol is a representative example and should be adapted and optimized based on laboratory conditions and scale.

Materials:

- 1,2-Difluorobenzene
- 4-Chlorobenzoyl chloride
- Anhydrous Aluminum Chloride (AlCl_3)
- Dichloromethane (DCM), anhydrous
- Hydrochloric Acid (HCl), concentrated
- Crushed Ice
- Standard laboratory glassware, dried in an oven

Procedure:

- Set up a three-neck round-bottom flask equipped with a magnetic stirrer, a dropping funnel, and a nitrogen inlet.
- Charge the flask with anhydrous aluminum chloride (1.1 eq) and anhydrous DCM.
- Cool the stirred suspension to 0-5 °C using an ice bath.
- Add 1,2-difluorobenzene (1.5-2.0 eq) to the flask.
- Dissolve 4-chlorobenzoyl chloride (1.0 eq) in a small amount of anhydrous DCM and add it to the dropping funnel.
- Add the 4-chlorobenzoyl chloride solution dropwise to the reaction mixture over 30-60 minutes, maintaining the internal temperature below 10 °C.
- After the addition is complete, allow the mixture to stir at 0-5 °C for one hour, then slowly warm to room temperature.
- Let the reaction stir at room temperature for 4-12 hours. Monitor the reaction progress by TLC.
- Upon completion, proceed with the workup as described in the purification protocol (Q5).

Protocol 2: Recrystallization of Crude Product

Materials:

- Crude **4-Chloro-3',4'-difluorobenzophenone**
- Ethanol (or other suitable solvent system)
- Erlenmeyer flask
- Hot plate
- Büchner funnel and filter flask

Procedure:

- Place the crude solid in an Erlenmeyer flask.
- Add a small amount of ethanol and heat the mixture gently on a hot plate with swirling until it boils.
- Continue to add small portions of hot ethanol until the solid just dissolves completely. Avoid adding excess solvent.
- Remove the flask from the heat and allow it to cool slowly to room temperature. Cover the flask to prevent solvent evaporation.
- Once cooled, place the flask in an ice bath for at least 30 minutes to maximize crystal formation.
- Collect the purified crystals by vacuum filtration using a Büchner funnel.
- Wash the crystals with a small amount of ice-cold ethanol.
- Dry the crystals in a vacuum oven to remove any residual solvent.

References

- SATHEE. (n.d.). Friedel Crafts Reaction.

- University of Calgary. (n.d.). 10.9. Reaction: Acylation via Friedel-Crafts. Introduction to Organic Chemistry.
- BYJU'S. (n.d.). Friedel Crafts Acylation And Alkylation Reaction. Retrieved from [\[Link\]](#)
- Master Organic Chemistry. (2018, May 17). EAS Reactions (3) - Friedel-Crafts Acylation and Friedel-Crafts Alkylation. Retrieved from [\[Link\]](#)
- Organic Chemistry Portal. (n.d.). Friedel-Crafts Acylation. Retrieved from [\[Link\]](#)
- Google Patents. (n.d.). CN114835563B - Synthesis method of 4,4' -difluorobenzophenone.
- Google Patents. (n.d.). CN106045828A - Preparation method of 4,4'-difluorobenzophenone.
- Google Patents. (n.d.). RU2394016C2 - 4,4'-difluorobenzophenone synthesis method.
- PrepChem.com. (n.d.). Synthesis of 4,4'-difluorobenzophenone. Retrieved from [\[Link\]](#)
- Request PDF. (2025, August 5). Short synthesis of 4-chloro-4'-(chlorodifluoromethoxy)benzophenone. Retrieved from [\[Link\]](#)
- Patsnap. (n.d.). A kind of preparation method of 4,4'-difluorobenzophenone - Eureka. Retrieved from [\[Link\]](#)
- European Patent Office. (n.d.). PROCESS FOR THE PREPARATION OF BENZOPHENTHIONES AND BENZOPHENONES - EP 0759903 B1. Retrieved from [\[Link\]](#)
- Wilkinson, M. C. (2011). "Greener" Friedel–Crafts Acylations: A Metal- and Halogen-Free Methodology. *Organic Letters*, 13(9), 2232–2235. DOI: 10.1021/ol2005839. Retrieved from [\[Link\]](#)
- Quick Company. (n.d.). "New Process For Preparing 4,4,' Difluorobenzophenone". Retrieved from [\[Link\]](#)
- Wikipedia. (2020, August 24). Friedel–Crafts reaction. Retrieved from [\[Link\]](#)
- Rueping, M., Nachtsheim, B. J., & Ie, W. (2010). A review of new developments in the Friedel–Crafts alkylation – From green chemistry to asymmetric catalysis. *Beilstein Journal of Organic Chemistry*, 6, 6. DOI: 10.3762/bjoc.6.6. Retrieved from [\[Link\]](#)

- Effenberger, F., & Epple, G. (n.d.). Catalytic Friedel-Crafts Acylation of Aromatic Compounds. Retrieved from [[Link](#)]
- ResearchGate. (n.d.). Synthesis of diaryl ketones from the reaction of... | Download Scientific Diagram. Retrieved from [[Link](#)]
- Chemguide. (n.d.). friedel-crafts acylation of benzene. Retrieved from [[Link](#)]
- Quick Company. (n.d.). Process For Preparation Of 4 Chloro 4' Hydroxy Benzophenone. Retrieved from [[Link](#)]
- Google Patents. (n.d.). CN102531872A - Method for preparing high purity (99.9 percent) 4,4'-difluorobenzophenone.
- 12BL Experiment 10: Friedel Crafts Acylation – An EAS Reaction. (n.d.). Retrieved from [[Link](#)]
- Wikipedia. (n.d.). 4,4'-Difluorobenzophenone. Retrieved from [[Link](#)]
- European Patent Office. (n.d.). Process for preparing chloro-difluorobenzene - EP 0447259 A1. Retrieved from [[Link](#)]
- Patsnap. (n.d.). Preparation method of 4-chloro-4'-hydroxybenzophenone - Eureka. Retrieved from [[Link](#)]

Need Custom Synthesis?

BenchChem offers custom synthesis for rare earth carbides and specific isotopic labeling.

Email: info@benchchem.com or [Request Quote Online](#).

Sources

- 1. [researchgate.net](https://www.researchgate.net) [[researchgate.net](https://www.researchgate.net)]
- 2. [SATHEE: Friedel Crafts Reaction](https://sathee.iitk.ac.in) [sathee.iitk.ac.in]
- 3. [masterorganicchemistry.com](https://www.masterorganicchemistry.com) [[masterorganicchemistry.com](https://www.masterorganicchemistry.com)]

- [4. 10.9. Reaction: Acylation via Friedel-Crafts – Introduction to Organic Chemistry \[saskoer.ca\]](#)
- [5. byjus.com \[byjus.com\]](#)
- [6. chemguide.co.uk \[chemguide.co.uk\]](#)
- [7. Iscollege.ac.in \[Iscollege.ac.in\]](#)
- [8. Friedel-Crafts Acylation \[organic-chemistry.org\]](#)
- [9. A kind of preparation method of 4,4'-difluorobenzophenone - Eureka | Patsnap \[eureka.patsnap.com\]](#)
- To cite this document: BenchChem. [Technical Support Center: Synthesis of 4-Chloro-3',4'-difluorobenzophenone]. BenchChem, [2026]. [Online PDF]. Available at: [\[https://www.benchchem.com/product/b1302634/docs#technical-support-center-synthesis-of-4-chloro-3-4-difluorobenzophenone\]](https://www.benchchem.com/product/b1302634/docs#technical-support-center-synthesis-of-4-chloro-3-4-difluorobenzophenone)

Disclaimer & Data Validity:

The information provided in this document is for Research Use Only (RUO) and is strictly not intended for diagnostic or therapeutic procedures. While BenchChem strives to provide accurate protocols, we make no warranties, express or implied, regarding the fitness of this product for every specific experimental setup.

Technical Support: The protocols provided are for reference purposes. Unsure if this reagent suits your experiment?

Need Industrial/Bulk Grade? [Request Custom Synthesis Quote](#)

BenchChem

Our mission is to be the trusted global source of essential and advanced chemicals, empowering scientists and researchers to drive progress in science and industry.

Contact

Address: 3281 E Guasti Rd
Ontario, CA 91761, United States
Phone: (601) 213-4426
Email: info@benchchem.com

Contact our Ph.D. Support Team for a compatibility check