

# Technical Support Center: Preventing Photodegradation of Benzophenone Compounds

**Author:** BenchChem Technical Support Team. **Date:** May 2026

## Compound of Interest

Compound Name:	<i>3,4-Dichloro-3'-fluoro-4'-methoxybenzophenone</i>
CAS No.:	844885-37-6
Cat. No.:	B1302692

[Get Quote](#)

Welcome to the technical support guide for researchers, scientists, and drug development professionals working with benzophenone compounds. This resource is designed to provide you with a deep understanding of the challenges associated with benzophenone photodegradation and to offer practical, field-proven solutions to ensure the integrity and reproducibility of your experiments.

## Introduction: The Double-Edged Sword of Benzophenone's Photochemistry

Benzophenone and its derivatives are invaluable in organic synthesis and pharmaceutical sciences, largely due to their unique photochemical properties. Upon absorption of ultraviolet (UV) light, benzophenone efficiently undergoes intersystem crossing to form a long-lived triplet excited state. This triplet state is a powerful hydrogen abstractor and energy transfer agent, making it a highly effective photoinitiator. However, this same reactivity is the root of its instability. When not productively channeled, this excited state can react with solvents,

reagents, or even other ground-state benzophenone molecules, leading to a cascade of degradation reactions. Understanding and controlling these pathways is critical for experimental success.

## Section 1: Foundational FAQs - Understanding the Risk

This section addresses the fundamental principles of benzophenone photodegradation.

### Q1: What is photodegradation, and why are benzophenone compounds particularly susceptible?

A: Photodegradation is the alteration of a molecule's chemical structure by light energy. Benzophenone is highly susceptible because its carbonyl group readily absorbs UV light (typically in the 280-350 nm range), promoting it to an excited triplet state.<sup>[1][2]</sup> This triplet state is a potent diradical that can initiate degradation through several mechanisms, most notably by abstracting a hydrogen atom from a donor molecule (like a solvent), which leads to the formation of a ketyl radical and subsequent undesired products.<sup>[3][4][5][6][7]</sup>

### Q2: What are the common degradation products, and how can they impact my experimental results?

A: The degradation products are highly dependent on the reaction environment. In the presence of hydrogen-donating solvents like isopropanol, the primary product is benzpinacol, formed by the dimerization of two ketyl radicals. In other environments, reactions with oxygen can lead to hydroxylated species and carboxylic acids.<sup>[1][2]</sup> These impurities can have significant consequences:

- **Analytical Interference:** Degradation products can appear as unexpected peaks in analytical techniques like HPLC and NMR, complicating quantification and characterization of the target compound.<sup>[8]</sup>
- **Reduced Yield:** The consumption of the starting material directly lowers the yield of the desired photoreaction.

- Altered Biological Activity: In drug development, photodegradants can exhibit different toxicity or efficacy profiles, compromising safety and stability studies.[9]

### Q3: Which experimental factors are most likely to accelerate photodegradation?

A: Several factors can significantly increase the rate of photodegradation:

- Light Intensity and Wavelength: Higher light intensity increases the rate of photon absorption and, consequently, degradation.[10] Light wavelengths that overlap with the benzophenone's absorption maximum are most damaging.[11]
- Solvent Choice: Solvents that are good hydrogen donors (e.g., alcohols like isopropanol, ethers like THF) readily react with the excited benzophenone triplet state, accelerating degradation.[3][4][5][6][7]
- Presence of Oxygen: Dissolved oxygen can interact with the excited triplet state to form reactive oxygen species (ROS), such as singlet oxygen, which can attack the parent compound or other molecules in the solution.[1][2]
- Temperature: While primarily a photochemical process, higher temperatures can sometimes increase the rates of secondary degradation reactions.

## Section 2: Proactive Prevention & Experimental Design - FAQs

This section provides actionable strategies to minimize degradation during your experiments.

### Q4: How should I select a solvent to minimize photodegradation?

A: The ideal solvent should be photochemically inert and a poor hydrogen donor.

- Recommended Solvents: Acetonitrile, benzene, and chlorinated solvents like dichloromethane are generally good choices as they are less susceptible to hydrogen abstraction.

- Solvents to Avoid: Protic solvents, especially secondary alcohols (e.g., isopropanol), should be avoided unless they are a required reactant. Ethers can also be problematic.
- Purity: Always use high-purity, peroxide-free solvents, as impurities can act as photosensitizers or reactants.

Solvent	Hydrogen Donating Ability	Suitability for Benzophenone Photostability
Isopropanol	High	Poor (Use only if it's a reactant)
Methanol	Moderate	Fair to Poor
Tetrahydrofuran (THF)	Moderate	Fair to Poor (Check for peroxides)
Acetonitrile	Low	Excellent
Dichloromethane	Low	Excellent
Benzene	Low	Good

## Q5: How can I control light exposure to protect my sample?

A: Precise control of light is the most direct way to prevent photodegradation.

- Use Cut-off Filters: If your desired reaction can be initiated by a specific wavelength, use optical filters to block the shorter, more damaging UV wavelengths that the benzophenone molecule absorbs strongly but may not be necessary for your process.<sup>[12]</sup>
- Limit Exposure Time: Only expose the sample to the light source for the minimum time required for the reaction.
- Use Amber Glassware: For storage and handling, always use amber or foil-wrapped glassware to protect the compound from ambient lab light.<sup>[12][13]</sup>

- **Control Intensity:** If possible, use a light source with adjustable intensity and perform initial experiments to find the lowest effective power setting.

## Q6: When and how should I use photostabilizers or quenchers?

A: When altering the solvent or light source is not feasible, chemical additives can protect your compound. These are categorized as UV absorbers or quenchers.

- **UV Absorbers:** These compounds, such as other, more stable benzophenone derivatives (e.g., benzophenone-3), can be added to a formulation to preferentially absorb damaging UV radiation.<sup>[14]</sup>
- **Triplet Quenchers:** These molecules accept energy from the excited triplet state of your benzophenone, returning it to the ground state before it can react. Sorbic acid and its salts are effective quenchers for benzophenone triplet states.<sup>[1][15]</sup> They are particularly useful in situations where the triplet state's reactivity is undesirable.

## Q7: What are the best practices for routine sample handling and storage?

A: Consistency in handling is key to reproducible results.

- **Work in a Dimly Lit Area:** When preparing solutions or setting up reactions, minimize exposure to direct overhead lighting.
- **Degas Solutions:** Before irradiation, sparge your solution with an inert gas like argon or nitrogen for 15-30 minutes to remove dissolved oxygen, which can participate in degradation pathways.
- **Use Dark Controls:** For any photostability study, always prepare an identical "dark control" sample wrapped completely in aluminum foil.<sup>[11]</sup> This sample is exposed to the same thermal conditions but not light, allowing you to differentiate between thermal and photodegradation.<sup>[11][16]</sup>

## Section 3: Troubleshooting Guide

This section helps you diagnose potential photodegradation issues in your experiments.

## Q8: My analytical results (HPLC, NMR) show unexpected peaks that grow over time. Could this be photodegradation?

A: Yes, this is a classic sign of photodegradation. To confirm:

- Analyze a Dark Control: Compare the chromatogram or spectrum of your light-exposed sample to a dark control that was prepared at the same time. If the extra peaks are absent or significantly smaller in the dark control, photodegradation is the likely cause.[\[11\]](#)
- Conduct a Time-Course Study: Analyze aliquots of your sample at different time points of light exposure. If the new peaks grow in intensity while your parent compound's peak decreases, this strongly indicates a degradation process.
- Identify Products: Use techniques like LC-MS to get the mass of the impurity peaks, which can help you identify common degradation products like benzpinacol or hydroxylated species.[\[1\]](#)[\[8\]](#)

## Q9: I'm observing a color change (e.g., yellowing) in my benzophenone solution upon light exposure. What does this signify?

A: A color change, typically to yellow or brown, often indicates the formation of conjugated degradation products. Benzophenone itself is colorless, so any development of color is a clear visual indicator that the parent molecule is being consumed and transformed into new chemical species. This is a qualitative but reliable sign that you need to implement preventative measures.

## Section 4: Key Experimental Protocols

### Protocol 1: Step-by-Step Guide to a Forced Photostability Study

This protocol, based on ICH Q1B guidelines, helps you assess the photosensitivity of your benzophenone compound.[\[12\]](#)[\[16\]](#)[\[17\]](#)[\[18\]](#)

Objective: To determine if a benzophenone compound is photolabile under controlled light exposure and to validate analytical methods for detecting degradants.

Materials:

- Benzophenone compound
- Chosen solvent (e.g., acetonitrile)
- Transparent, chemically inert vials (e.g., quartz or borosilicate glass)[\[18\]](#)
- Aluminum foil
- Calibrated photostability chamber with a light source capable of emitting both cool white fluorescent and near-UV light.[\[16\]](#)
- Validated HPLC or UPLC method.

Procedure:

- Sample Preparation: Prepare a solution of your compound at a known concentration. For solid samples, place a thin, uniform layer (not more than 3mm) in a suitable container.[\[12\]](#)
- Create Sample Sets:
  - Exposed Sample: Place the sample in a transparent vial.
  - Dark Control: Place an identical sample in a vial and wrap it securely and completely in aluminum foil.[\[11\]](#)
- Exposure: Place both samples in the photostability chamber. Expose them to a minimum overall illumination of 1.2 million lux-hours and an integrated near-UV energy of 200 watt-hours per square meter.[\[12\]](#)[\[18\]](#)

- Analysis: After exposure, analyze both the exposed sample and the dark control using your validated analytical method.
- Evaluation:
  - Compare the chromatograms. Note any new peaks in the exposed sample that are not present in the dark control.
  - Calculate the loss of the parent compound and the formation of impurities (as a percentage of the parent).
  - If significant change is observed, the compound is considered photolabile, and protective measures are required.

## Protocol 2: Using a Triplet Quencher to Stabilize a Benzophenone Solution

Objective: To inhibit a photodegradation pathway mediated by the benzophenone triplet state.

Materials:

- Benzophenone solution in a suitable solvent.
- Triplet quencher (e.g., Sorbic Acid or Potassium Sorbate).
- Light source for the experiment.

Procedure:

- Determine Quencher Concentration: Start with a quencher concentration that is equimolar to the benzophenone compound. This can be optimized later.
- Prepare Solutions:
  - Test Solution: Prepare your benzophenone solution and add the calculated amount of the triplet quencher. Ensure it is fully dissolved.
  - Control Solution: Prepare an identical benzophenone solution without the quencher.

- Degas: Sparge both solutions with argon or nitrogen for 15 minutes to remove oxygen.
- Irradiation: Irradiate both the test and control solutions under identical conditions (same light source, duration, and temperature).
- Analysis: Analyze both solutions using HPLC or another quantitative method.
- Evaluation: Compare the amount of degradation in the test solution to the control. A significant reduction in degradation in the presence of the quencher confirms that the reaction proceeds via the triplet state and that the quencher is effective.[1][15]

## Section 5: Visualized Workflows and Mechanisms

### Workflow for Assessing and Mitigating Photodegradation Risk

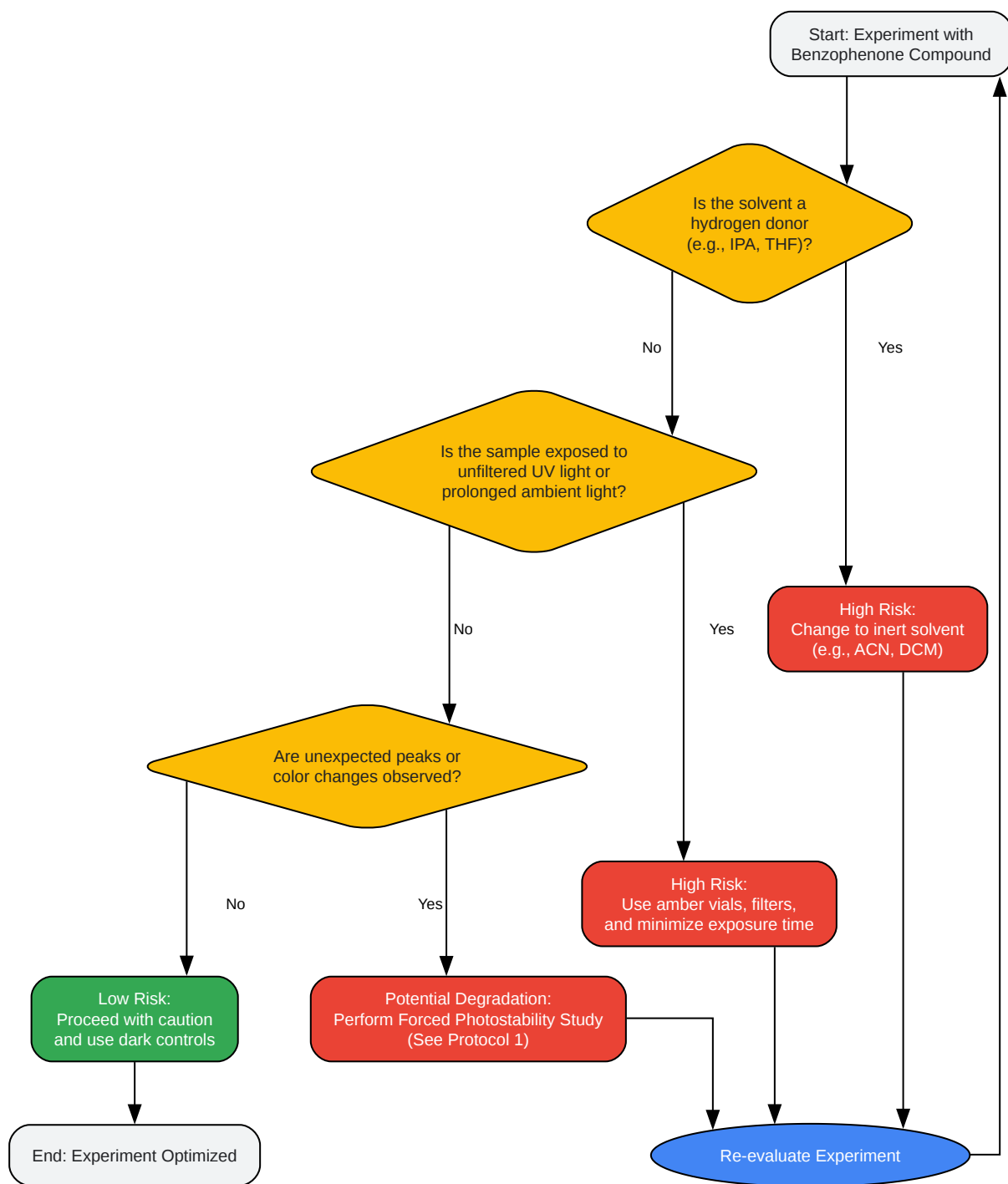

[Click to download full resolution via product page](#)

Caption: Decision workflow for identifying and mitigating photodegradation risks.

## Simplified Mechanism of Benzophenone Photoreduction

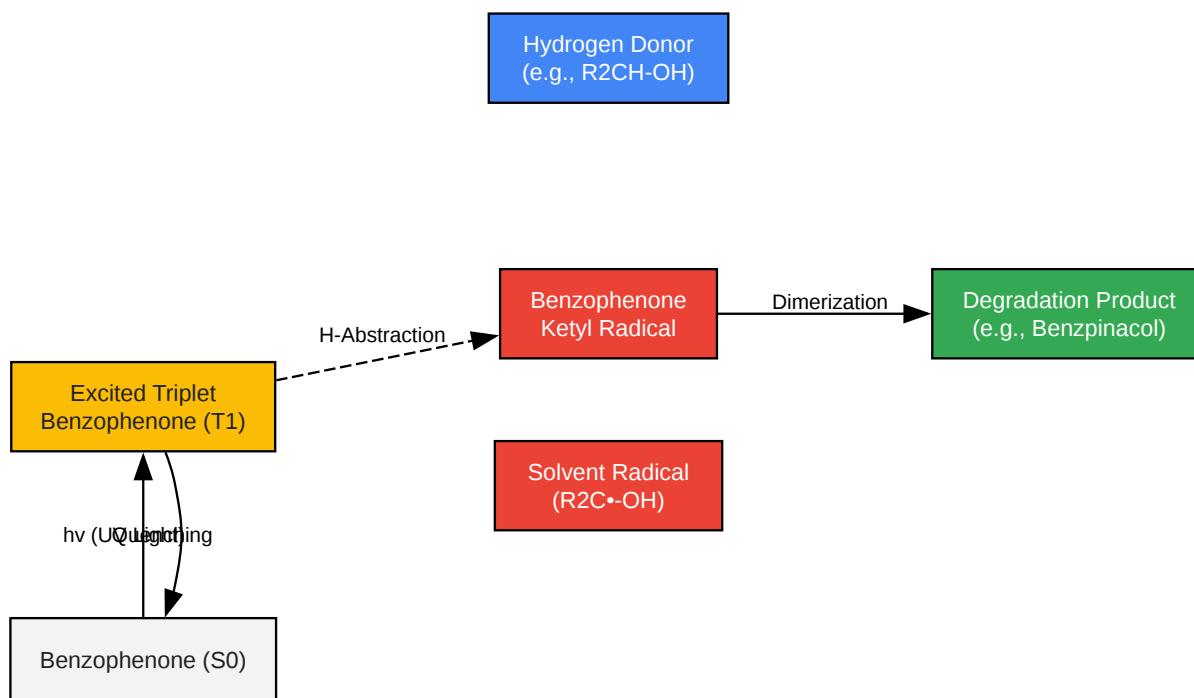

[Click to download full resolution via product page](#)

Caption: Pathway of benzophenone photoreduction via hydrogen abstraction.

## References

- BioBoston Consulting. (2024, November 5). Guide to Photostability Testing: ICH Guidelines.
- ICH. (2025, May 1). ICH Q1B Guideline (Photostability Testing for New Drug Substances and Products).
- ECA Academy. ICH Q1B Stability Testing: Photostability Testing of New Drug Substances and Products.
- Venkatraman, R. K., & Orr-Ewing, A. J. (2019). Photochemistry of Benzophenone in Solution: A Tale of Two Different Solvent Environments. *Journal of the American Chemical Society*, 141(38), 15222–15229.
- Royal Society of Chemistry. (2025, July 28). Emerging investigator series: release and phototransformation of benzophenone additives from polystyrene plastics exposed to sunlight. *Environmental Science: Processes & Impacts*.
- RSC Publishing. (2025, July 28). Release and phototransformation of benzophenone additives from polystyrene plastics exposed to sun.

- ICH. STABILITY TESTING: PHOTOSTABILITY TESTING OF NEW DRUG SUBSTANCES AND PRODUCTS.
- Venkatraman, R. K., & Orr-Ewing, A. J. (2019, September 25). Photochemistry of Benzophenone in Solution: A Tale of Two Different Solvent Environments. *Journal of the American Chemical Society*.
- ResearchGate. (2025, August 6). ICH guideline for photostability testing: Aspects and directions for use.
- Venkatraman, R. K., & Orr-Ewing, A. J. (2019, September 3). Photochemistry of Benzophenone in Solution: A Tale of Two Different Solvent Environments. *Journal of the American Chemical Society*.
- SciSpace. Photochemistry of Benzophenone in Solution: A Tale of Two Different Solvent Environments.
- ResearchGate. Photochemistry of Benzophenone in Solution: A Tale of Two Different Solvent Environments | Request PDF.
- Photochemical reaction mechanisms and kinetics with molecular nanocrystals: surface quenching of triplet benzophenone nanocrysta.
- PubMed Central.
- Kotnik, K., et al. (2016). Photolytic fate and genotoxicity of benzophenone-derived compounds and their photodegradation mixtures in the aqueous environment. *PubMed*, 15.
- Taylor & Francis Online.
- ResearchGate.
- ResearchGate. (2025, September 17). Emerging investigator series: release and phototransformation of benzophenone additives from polystyrene plastics exposed to sunlight.
- The Royal Society of Chemistry. Supplementary Information Release and Phototransformation of Benzophenone Additives from Polystyrene Plastics Exposed to Sunligh.
- NIH. Implementation of Sensitive Method for Determination of Benzophenone and Camphor UV Filters in Human Urine. *PMC*.
- Solid-phase extraction coupled simple on-line derivatization gas chromatography - tandem mass spectrometry for the determination of benzophenone-type UV filters in aqueous samples.
- da Silva, A. C. R., et al. (Year). Investigation of the stabilizing effects of antioxidants and benzophenone-3 on desonide photostability. *PubMed*.
- SciSpace. (2012, February 24). Photocatalytic Degradation of Organic Pollutants: Mechanisms and Kinetics.
- YouTube. (2024, June 9).
- NIH.

- Q1 Scientific. (2021, July 28). Photostability testing theory and practice.
- MDPI. Organic Pollutant Degradation Through Photocatalysis: Progress, Challenges, and Sustainable Solutions (Mini Review).
- Svad, D., & Lhiaubet-Vallet, V. (2010, October 7). Quenching of triplet benzophenone by benzene and diphenyl ether: a DFT study. PubMed.
- ACS Omega. (2021, November 5). Mechanism of Photodegradation of Organic Pollutants in Seawater by TiO<sub>2</sub>-Based Photocatalysts and Improvement in Their Performance.
- Chemical Communications (RSC Publishing).
- Sci-Hub. Quenching of Triplet Benzophenone by Benzene and Diphenyl Ether: A DFT Study.
- Semantic Scholar. Quenching of triplet benzophenone by electron donors.

### Need Custom Synthesis?

BenchChem offers custom synthesis for rare earth carbides and specific isotopic labeling.

Email: [info@benchchem.com](mailto:info@benchchem.com) or [Request Quote Online](#).

## Sources

- [1. Emerging investigator series: release and phototransformation of benzophenone additives from polystyrene plastics exposed to sunlight - Environmental Science: Processes & Impacts \(RSC Publishing\) DOI:10.1039/D5EM00292C \[pubs.rsc.org\]](#)
- [2. pubs.rsc.org \[pubs.rsc.org\]](#)
- [3. \[PDF\] Photochemistry of Benzophenone in Solution: A Tale of Two Different Solvent Environments. | Semantic Scholar \[semanticscholar.org\]](#)
- [4. Photochemistry of Benzophenone in Solution: A Tale of Two Different Solvent Environments - PubMed \[pubmed.ncbi.nlm.nih.gov\]](#)
- [5. pubs.acs.org \[pubs.acs.org\]](#)
- [6. scispace.com \[scispace.com\]](#)
- [7. researchgate.net \[researchgate.net\]](#)
- [8. rsc.org \[rsc.org\]](#)
- [9. Photolytic fate and genotoxicity of benzophenone-derived compounds and their photodegradation mixtures in the aqueous environment - PubMed \[pubmed.ncbi.nlm.nih.gov\]](#)
- [10. Organic Pollutant Degradation Through Photocatalysis: Progress, Challenges, and Sustainable Solutions \(Mini Review\) \[mdpi.com\]](#)

- [11. q1scientific.com \[q1scientific.com\]](https://www.q1scientific.com)
- [12. youtube.com \[youtube.com\]](https://www.youtube.com)
- [13. researchgate.net \[researchgate.net\]](https://www.researchgate.net)
- [14. Investigation of the stabilizing effects of antioxidants and benzophenone-3 on desonide photostability - PubMed \[pubmed.ncbi.nlm.nih.gov\]](https://pubmed.ncbi.nlm.nih.gov)
- [15. researchgate.net \[researchgate.net\]](https://www.researchgate.net)
- [16. biobostonconsulting.com \[biobostonconsulting.com\]](https://www.biobostonconsulting.com)
- [17. ICH Q1B Stability Testing: Photostability Testing of New Drug Substances and Products - ECA Academy \[gmp-compliance.org\]](https://www.gmp-compliance.org)
- [18. database.ich.org \[database.ich.org\]](https://www.database.ich.org)
- To cite this document: BenchChem. [Technical Support Center: Preventing Photodegradation of Benzophenone Compounds]. BenchChem, [2026]. [Online PDF]. Available at: [\[https://www.benchchem.com/product/b1302692/docs#technical-support-center-preventing-photodegradation-of-benzophenone-compounds\]](https://www.benchchem.com/product/b1302692/docs#technical-support-center-preventing-photodegradation-of-benzophenone-compounds)

---

### Disclaimer & Data Validity:

The information provided in this document is for Research Use Only (RUO) and is strictly not intended for diagnostic or therapeutic procedures. While BenchChem strives to provide accurate protocols, we make no warranties, express or implied, regarding the fitness of this product for every specific experimental setup.

**Technical Support:** The protocols provided are for reference purposes. Unsure if this reagent suits your experiment?

**Need Industrial/Bulk Grade?** [Request Custom Synthesis Quote](#)

## BenchChem

Our mission is to be the trusted global source of essential and advanced chemicals, empowering scientists and researchers to drive progress in science and industry.

### Contact

Address: 3281 E Guasti Rd  
Ontario, CA 91761, United States  
Phone: (601) 213-4426  
Email: [info@benchchem.com](mailto:info@benchchem.com)

Contact our Ph.D. Support Team for a compatibility check