

Technical Support Center: Optimization of Reaction Temperature for 2-Bromoallylation

Author: BenchChem Technical Support Team. **Date:** February 2026

Compound of Interest

Compound Name: 2-Bromo-3-(3-chloro-4-fluorophenyl)-1-propene

CAS No.: 842140-28-7

Cat. No.: B1302583

[Get Quote](#)

Current Status: Operational Subject: Thermal Management in 2-Bromoallylation Protocols
Assigned Specialist: Senior Application Scientist

Executive Summary: The Thermal "Goldilocks" Zone

2-Bromoallylation—the installation of a 2-bromoallyl group (

)—is a pivotal transformation in the synthesis of functionalized heterocycles and cross-coupling precursors. However, it presents a unique thermodynamic challenge:

- The Reagent: 2,3-Dibromopropene (and its surrogates) contains two electrophilic sites: the allylic bromide () and the vinylic bromide ().
- The Conflict: You require sufficient thermal energy to overcome the activation barrier for oxidative addition at the allylic position (Path A), but excessive heat triggers -bromo elimination (Path B) or oxidative addition at the vinylic position (Path C), leading to allenes or polymerization.

This guide provides the thermal parameters to navigate this selectivity cliff.

Diagnostic Workflow: Temperature-Dependent Pathways

The following diagram illustrates the kinetic divergence based on reaction temperature in Palladium-catalyzed systems.

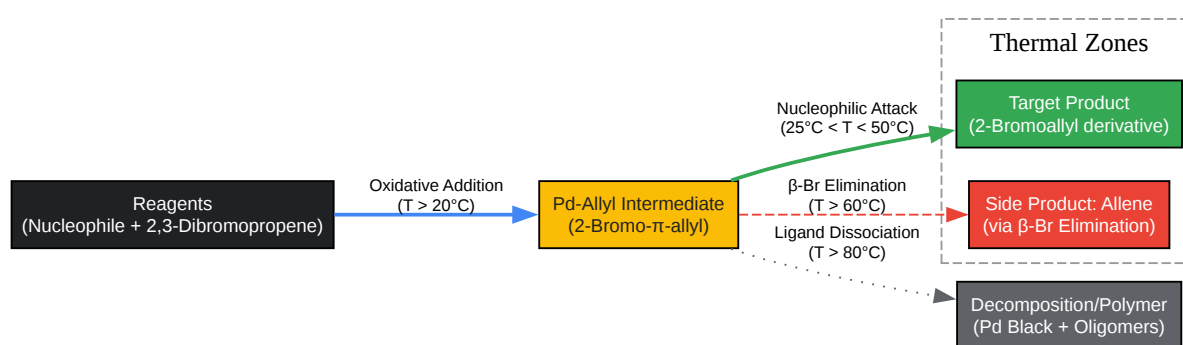

[Click to download full resolution via product page](#)

Figure 1: Kinetic divergence in Pd-catalyzed 2-bromoallylation. Note the narrow window for product formation versus elimination.

Standard Operating Procedures (SOPs)

Module A: Palladium-Catalyzed 2-Bromoallylation

Target: Alkylation of active methylenes (malonates, keto-esters).

The Critical Insight: The C(2)-Br bond in the

-allyl intermediate destabilizes the complex compared to a standard allyl group. High temperatures accelerate the ejection of Bromide to form a propargyl/allenylic species.

Optimized Protocol:

- Base Activation (Pre-Cooling): Dissolve nucleophile (1.0 equiv) and Base (NaH or

-) in THF or DMF. Stir at 0°C for 30 mins.
- Why? Ensure complete deprotonation before introducing the electrophile to prevent background elimination.
 - Catalyst Induction (Ambient): Add Pd source (e.g.,
, 5 mol%) and 2,3-dibromopropene (1.2 equiv) at 25°C.
 - The Ramp (Stepwise Heating):
 - Stir at 25°C for 1 hour. Check TLC.
 - If conversion < 20%:: Increase T to 40-45°C.
 - HARD CEILING: Do not exceed 60°C.[1]
 - Quench: Cool to 0°C before adding saturated
.

Module B: Indium-Mediated Barbier Reaction

Target: 2-Bromoallylation of Aldehydes/Ketones.

The Critical Insight: This reaction is exothermic.[2] The "induction period" is the danger zone. If you heat to start the reaction, the sudden exotherm can cause a runaway, leading to Wurtz-coupling (dimerization of the bromide).

Optimized Protocol:

- Setup: Mix Aldehyde (1.0 equiv) and 2,3-dibromopropene (1.5 equiv) in THF/H₂O (1:1).
- Initiation (The "Cold" Start): Add Indium powder (1.2 equiv) and NaI (0.5 equiv) at 0°C.
- Reaction: Allow to warm slowly to Room Temperature (20-25°C).
 - Warning: Do not reflux. If the reaction is sluggish, sonicate at RT rather than heating.

Troubleshooting Matrix

Symptom	Probable Cause	Thermal Diagnosis	Corrective Action
Formation of Allene	-Bromide Elimination	Too Hot (>60°C). The Pd-center eliminates HBr instead of transferring the allyl group.	Reduce T to 40°C. Switch solvent to THF (lower bp) to physically limit T.
Pd Black Precipitates	Catalyst Decomposition	Too Hot. Ligands () dissociate, causing Pd aggregation.	Add excess ligand (10-20 mol%). Keep T < 50°C.
Low Conversion (Start Material Remains)	High Activation Barrier	Too Cold. Oxidative addition into C-Br is rate-limiting.	Increase T in 5°C increments. Add TBAI (Tetrabutylammonium iodide) to facilitate halide exchange at lower T.
Dimerization (Wurtz Product)	Radical Coupling	Uncontrolled Exotherm. (Indium/Zinc methods).	Cool to 0°C during metal addition. Dilute reaction (0.1 M).

Frequently Asked Questions (FAQs)

Q1: My reaction stalls at 50% conversion at 40°C. Should I crank the heat to 80°C?

A: Absolutely not. In 2-bromoallylation, 80°C is the "kill zone." At this temperature, the 2-bromo-allyl palladium complex becomes unstable. It will likely undergo -elimination to form the allene (which may polymerize) or protodebromination.

- Better Strategy: Add a fresh portion of catalyst (2 mol%) and reagents, or switch to a more reactive ligand like dppe or dppf, which bite harder and stabilize the complex at 40°C.

Q2: Why do protocols often recommend adding NaI or TBAI? A: This is a kinetic trick to lower the temperature requirement. Iodide (

) displaces the allylic Bromide in situ to form 2-bromoallyl iodide. The C-I bond undergoes oxidative addition to Palladium (or Indium) much faster and at lower temperatures than the C-Br bond. This allows you to run the reaction at RT or 40°C instead of risking 60°C+.

Q3: I see "Protodebromination" (loss of Br) in my product. Why? A: This is a classic sign of overheating in the presence of a hydride source. If you are using a solvent like ethanol or isopropanol at high temperatures (>70°C), the Pd can perform a

-hydride elimination on the solvent, form a Pd-H species, and reduce your vinyl bromide.

- Fix: Use non-protic solvents (THF, DMF, Toluene) and keep T < 50°C.

References

- Palladium-Catalyzed 2-Bromoallyl
 - Source: J. Org. Chem. (Tsuji-Trost Type Reactions)
 - Context: Establishes the instability of 2-bromo- π -allyl complexes at high temper
- Indium-Mediated Allyl
 - Source: Tetrahedron Letters / NIH PubMed Central
 - Context: Details the room-temperature Barbier conditions using Indium and additives like TBAI.
- Temperature Dependence of 2,3-Dibromopropene Reactivity
 - Source: GuideChem / Chemical Safety D
 - Context: Physical properties and thermal decomposition risks of the reagent.[\[3\]](#)
- Mechanistic Studies on Pd-Allyl Stability
 - Source: Journal of the American Chemical Society (JACS)
 - Context: Fundamental organometallic studies on β -elimination p

Need Custom Synthesis?

BenchChem offers custom synthesis for rare earth carbides and specific isotopic labeling.

Email: info@benchchem.com or [Request Quote Online](#).

Sources

- [1. thieme-connect.de](https://thieme-connect.de) [thieme-connect.de]
- [2. benchchem.com](https://benchchem.com) [benchchem.com]
- [3. Page loading...](https://wap.guidechem.com) [wap.guidechem.com]
- To cite this document: BenchChem. [Technical Support Center: Optimization of Reaction Temperature for 2-Bromoallylation]. BenchChem, [2026]. [Online PDF]. Available at: [<https://www.benchchem.com/product/b1302583#optimization-of-reaction-temperature-for-2-bromoallylation>]

Disclaimer & Data Validity:

The information provided in this document is for Research Use Only (RUO) and is strictly not intended for diagnostic or therapeutic procedures. While BenchChem strives to provide accurate protocols, we make no warranties, express or implied, regarding the fitness of this product for every specific experimental setup.

Technical Support: The protocols provided are for reference purposes. Unsure if this reagent suits your experiment? [[Contact our Ph.D. Support Team for a compatibility check](#)]

Need Industrial/Bulk Grade? [Request Custom Synthesis Quote](#)

BenchChem

Our mission is to be the trusted global source of essential and advanced chemicals, empowering scientists and researchers to drive progress in science and industry.

Contact

Address: 3281 E Guasti Rd

Ontario, CA 91761, United States

Phone: (601) 213-4426

Email: info@benchchem.com

