

# Technical Guide: Characterization and Handling of 6-Bromo-2-hydroxy-3-methoxybenzaldehyde

**Author:** BenchChem Technical Support Team. **Date:** April 2026

## Compound of Interest

**Compound Name:** 6-Bromo-2-ethoxy-3-methoxybenzaldehyde

**Cat. No.:** B13013752

[Get Quote](#)

## Executive Summary

6-Bromo-2-hydroxy-3-methoxybenzaldehyde (CAS 20035-41-0), often distinctively referred to as 6-bromo-o-vanillin, represents a critical halogenated scaffold in medicinal chemistry. Unlike its more common isomer, 5-bromo-o-vanillin, the 6-bromo variant introduces significant steric crowding around the aldehyde functionality, altering its reactivity in Schiff base formation and metal coordination.

This guide provides a definitive technical profile of the compound, resolving common confusion regarding its regioselectivity, melting point, and thermal stability. It serves as a grounded reference for researchers utilizing this scaffold in the synthesis of IRE1

inhibitors and complex natural product derivatives like (

)-norannuradhapurine.

## Physicochemical Profile

The distinction between the 6-bromo and 5-bromo isomers is the most frequent source of error in procurement and synthesis. The data below applies strictly to the 6-bromo regioisomer (CAS

20035-41-0).

## Core Properties Table

Property	Value / Description	Confidence Level
CAS Number	20035-41-0	High (Verified)
IUPAC Name	6-Bromo-2-hydroxy-3-methoxybenzaldehyde	High
Molecular Formula	C H BrO	High
Molecular Weight	231.04 g/mol	High
Melting Point (MP)	102 – 105 °C	Experimental (Lit.) <sup>[1][2]</sup>
Boiling Point (BP)	282.1 ± 35.0 °C (Predicted)	Theoretical*
Appearance	Light yellow to orange crystalline powder	Experimental
Solubility	Soluble in DMSO (113 mg/mL), Methanol, DCM	Experimental
pKa	7.21 ± 0.15 (Predicted)	Theoretical

\*Note on Boiling Point: Like many poly-functionalized benzaldehydes, this compound is prone to sublimation and oxidative decomposition prior to reaching its atmospheric boiling point. Distillation is not recommended; purification should proceed via recrystallization or chromatography.

## Structural Identification (Isomer Differentiation)

Researchers must validate the regiochemistry using

H-NMR. The 6-bromo isomer possesses a unique substitution pattern (C1-CHO, C2-OH, C3-OMe, C6-Br).

- Proton Environment: The aromatic protons at C4 and C5 are ortho to each other.
- Expected Signal: Two doublets ( Hz) in the aromatic region (approx. 7.0–7.4 ppm).[3]
- Contrast: The 5-bromo isomer (CAS 2973-76-4) has protons at C4 and C6, which are meta to each other, typically appearing as two doublets with a small coupling constant ( Hz) or singlets.

## Regioselectivity and Synthesis Logic

The synthesis of the 6-bromo isomer is non-trivial because the direct bromination of o-vanillin strongly favors the 5-position (para to the activating hydroxyl group). Accessing the 6-position requires blocking the 5-position or utilizing directed lithiation strategies.

## Regioisomer Landscape

The following diagram illustrates the structural relationship and the steric environment of the target compound compared to its common impurities.

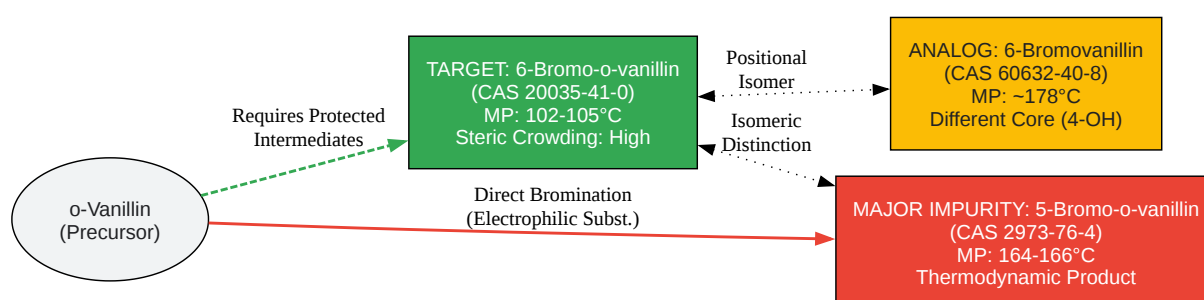

[Click to download full resolution via product page](#)

Figure 1: Isomer landscape highlighting the difficulty in accessing the 6-bromo regioisomer via direct electrophilic substitution.

## Experimental Protocol: Hydrolysis & Isolation

Due to the difficulty of direct synthesis, the most reliable lab-scale protocol involves the hydrolysis of a protected precursor, such as 2-acetoxy-3-methoxy-6-bromobenzaldehyde. This method ensures high purity by separating the bromination step from the final deprotection.

### Protocol: Acid-Mediated Deprotection

Objective: Isolation of 6-bromo-2-hydroxy-3-methoxybenzaldehyde from its acetoxy precursor.  
[2]

Reagents:

- Precursor: 2-Acetoxy-3-methoxy-6-bromobenzaldehyde[2]
- Solvent: Methanol (MeOH), HPLC grade
- Reagent: 6N Hydrochloric Acid (HCl)[2][4]
- Wash: Petroleum Ether[2]

Step-by-Step Methodology:

- Dissolution: Charge a round-bottom flask with 2-acetoxy-3-methoxy-6-bromobenzaldehyde (1.0 eq). Dissolve in Methanol (approx. 3 mL per gram of precursor).
- Hydrolysis: Slowly add 6N HCl (1:1 volume ratio relative to MeOH) to the stirring solution.
  - Mechanism:[5] Acid-catalyzed hydrolysis of the ester (acetate) to restore the phenol.
- Reaction: Stir the mixture at room temperature (20–25 °C) for 12–16 hours. Monitor via TLC (SiO<sub>2</sub>, Hexane:EtOAc 3:1) for the disappearance of the acetate spot.
- Work-up:
  - The product typically precipitates as the methanol evaporates or upon cooling.

- Separate the solid via filtration (Diafiltration or Büchner funnel).
- Purification: Wash the filter cake with Petroleum Ether (volumes) to remove non-polar organic impurities.
- Drying: Dry the yellow solid under vacuum at 40 °C to constant weight.

Expected Yield: ~95–99% Target MP: 102–105 °C

## Synthesis Workflow Diagram

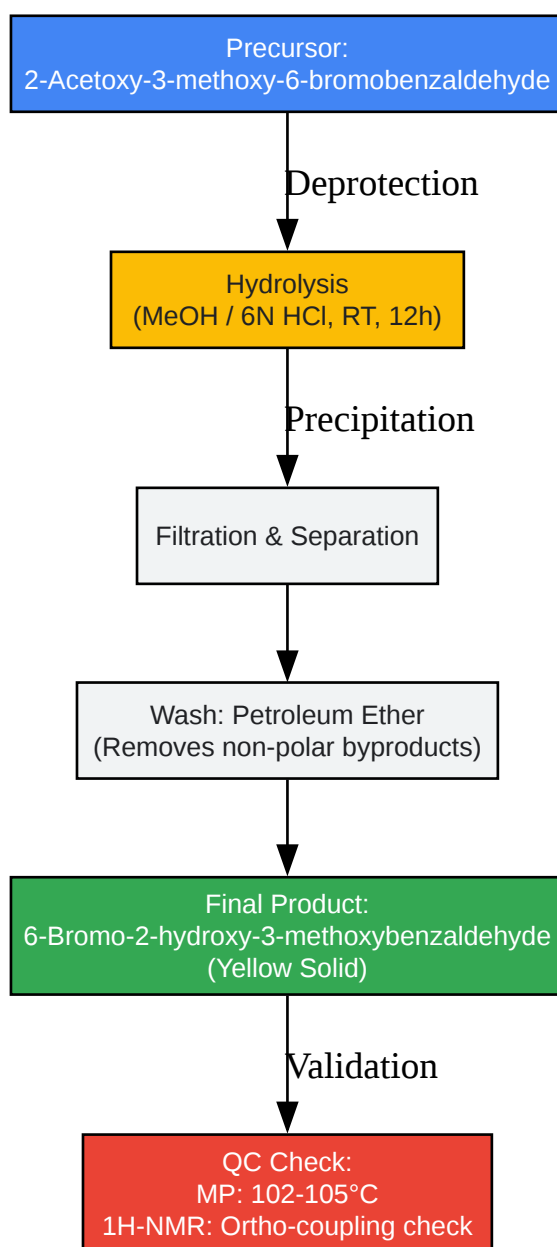

[Click to download full resolution via product page](#)

Figure 2: Workflow for the final stage isolation of the target compound.

## Applications in Drug Discovery

The 6-bromo-2-hydroxy-3-methoxybenzaldehyde scaffold is not merely a building block; it possesses intrinsic biological activity and serves as a pharmacophore precursor.

- IRE1

Inhibition: The compound has been identified as an inhibitor of Inositol-Requiring Enzyme 1 alpha (IRE1

), a key sensor in the Unfolded Protein Response (UPR) pathway. This makes it relevant in oncology research targeting ER stress.

- Natural Product Synthesis: It is a verified intermediate in the total synthesis of (

)-norannuradhapurine, an isoquinoline alkaloid.

- Schiff Base Ligands: The proximity of the bromine atom to the aldehyde group (position 6 vs position 1) creates a specific steric pocket. When condensed with amines to form Schiff bases, the resulting ligands exhibit unique coordination geometries with transition metals, often utilized in catalysis.

## Safety and Handling

- Hazards: Classed as an Irritant (Xi).[4] Causes skin irritation and serious eye irritation.
- Storage: Store at Room Temperature (15–25 °C). Keep container tightly sealed in a dry, well-ventilated place.
- Air Sensitivity: While relatively stable, prolonged exposure to air may oxidize the aldehyde to the corresponding benzoic acid. Store under inert gas (Argon/Nitrogen) for long-term retention of purity.

## References

- Sigma-Aldrich.6-Bromo-2-hydroxy-3-methoxybenzaldehyde Product Sheet. (Accessed 2026).[2][6] [Link](#)
- TCI Chemicals.Product Specification: 6-Bromo-2-hydroxy-3-methoxybenzaldehyde (B1487). [Link](#)
- ChemicalBook.Synthesis and Properties of CAS 20035-41-0. [Link](#)
- SelleckChem.6-Bromo-2-hydroxy-3-methoxybenzaldehyde: IRE1 Inhibitor Data. [Link](#)
- PrepChem.Synthesis of substituted benzaldehydes. [Link](#)

### Need Custom Synthesis?

BenchChem offers custom synthesis for rare earth carbides and specific isotopic labeling.

Email: [info@benchchem.com](mailto:info@benchchem.com) or [Request Quote Online](#).

## Sources

- [1. 6-BROMO-2-HYDROXY-3-METHOXYBENZALDEHYDE price,buy 6-BROMO-2-HYDROXY-3-METHOXYBENZALDEHYDE - chemicalbook \[chemicalbook.com\]](#)
- [2. 6-BROMO-2-HYDROXY-3-METHOXYBENZALDEHYDE | 20035-41-0 \[chemicalbook.com\]](#)
- [3. cdnsciencepub.com \[cdnsciencepub.com\]](#)
- [4. 6-Bromovanillin CAS#: 60632-40-8 \[m.chemicalbook.com\]](#)
- [5. prepchem.com \[prepchem.com\]](#)
- [6. buyersguidechem.com \[buyersguidechem.com\]](#)
- To cite this document: BenchChem. [Technical Guide: Characterization and Handling of 6-Bromo-2-hydroxy-3-methoxybenzaldehyde]. BenchChem, [2026]. [Online PDF]. Available at: [\[https://www.benchchem.com/product/b13013752/docs#technical-guide-characterization-and-handling-of-6-bromo-2-hydroxy-3-methoxybenzaldehyde\]](https://www.benchchem.com/product/b13013752/docs#technical-guide-characterization-and-handling-of-6-bromo-2-hydroxy-3-methoxybenzaldehyde)

---

### Disclaimer & Data Validity:

The information provided in this document is for Research Use Only (RUO) and is strictly not intended for diagnostic or therapeutic procedures. While BenchChem strives to provide accurate protocols, we make no warranties, express or implied, regarding the fitness of this product for every specific experimental setup.

**Technical Support:** The protocols provided are for reference purposes. Unsure if this reagent suits your experiment?

**Need Industrial/Bulk Grade?** [Request Custom Synthesis Quote](#)

## BenchChem

Our mission is to be the trusted global source of essential and advanced chemicals, empowering scientists and researchers to drive progress in science and industry.

### Contact

Address: 3281 E Guasti Rd  
Ontario, CA 91761, United States  
Phone: (601) 213-4426  
Email: [info@benchchem.com](mailto:info@benchchem.com)

[Contact our Ph.D. Support Team for a compatibility check](#)