

Technical Guide: 6-Fluorophthalazine Crystal Structure Analysis

Author: BenchChem Technical Support Team. **Date:** April 2026

Compound of Interest

Compound Name: 6-Fluorophthalazine

Cat. No.: B13010646

[Get Quote](#)

Executive Summary & Chemical Context

6-Fluorophthalazine (and its oxidized derivative 6-fluoro-1(2H)-phthalazinone) represents a critical pharmacophore in medicinal chemistry, serving as the structural core for PARP inhibitors (e.g., Olaparib analogs) and VEGFR inhibitors.

In the solid state, this scaffold presents a dual challenge for crystallographic analysis:

- **Tautomeric Ambiguity:** Distinguishing between the lactam (NH-C=O) and lactim (N=C-OH) forms in the phthalazinone derivative.
- **Fluorine-Mediated Packing:** The fluorine atom at position 6 introduces strong electronic polarization, directing packing motifs via non-classical

and

interactions, which significantly alter solubility and bioavailability compared to the non-fluorinated parent.

This guide provides the methodology to grow, solve, and analyze these specific crystal structures.

Crystallization Strategy

Obtaining diffraction-quality single crystals of fluorinated heterocycles requires balancing the polarity of the diaza-ring with the lipophilicity of the fluorine substituent.

Solvent Selection Matrix

Solvent System	Method	Target Polymorph/Habit	Causality
Ethanol/Water (4:1)	Slow Evaporation	Prisms / Blocks	Promotes H-bonding networks (Lactam form favored). High dielectric constant stabilizes the polar amide.
Acetonitrile	Cooling (-20°C)	Needles	Favors - stacked motifs. Aprotic environment minimizes solvent inclusion.
THF/Hexane	Vapor Diffusion	Plates	Slow nucleation for highly soluble derivatives. Hexane forces the lipophilic F-edge to aggregate.

Protocol: Seeding for Tautomeric Purity

Context: Phthalazinones can crystallize as mixed tautomers if proton transfer is fast in solution.

- Dissolution: Dissolve 50 mg of 6-fluoro-1(2H)-phthalazinone in 4 mL hot ethanol.
- Filtration: Filter through a 0.45 μm PTFE syringe filter to remove dust (nucleation sites).

- Acidification (Optional): Add 10 μL of 0.1M HCl. Reasoning: Protonation of N2 prevents lactim formation, forcing the lactam (NH) crystallization.
- Incubation: Place in a vibration-free environment at 4°C.

Data Acquisition & Structure Solution

X-Ray Diffraction Parameters

- Temperature: 100 K (Liquid Nitrogen stream).
 - Why: Fluorine atoms often exhibit high thermal motion or positional disorder (rotational) at room temperature. Low T freezes the C-F bond libration.

- Radiation: Mo-K

(

Å) or Cu-K

(

Å).

- Recommendation: Use Cu-K

for small organic crystals to maximize diffraction intensity, as **6-fluorophthalazine** contains no heavy atoms to cause significant absorption.

Structure Solution Workflow

The following diagram outlines the logical flow for solving the structure, specifically addressing the "Fluorine Disorder" and "Tautomer Check" checkpoints.

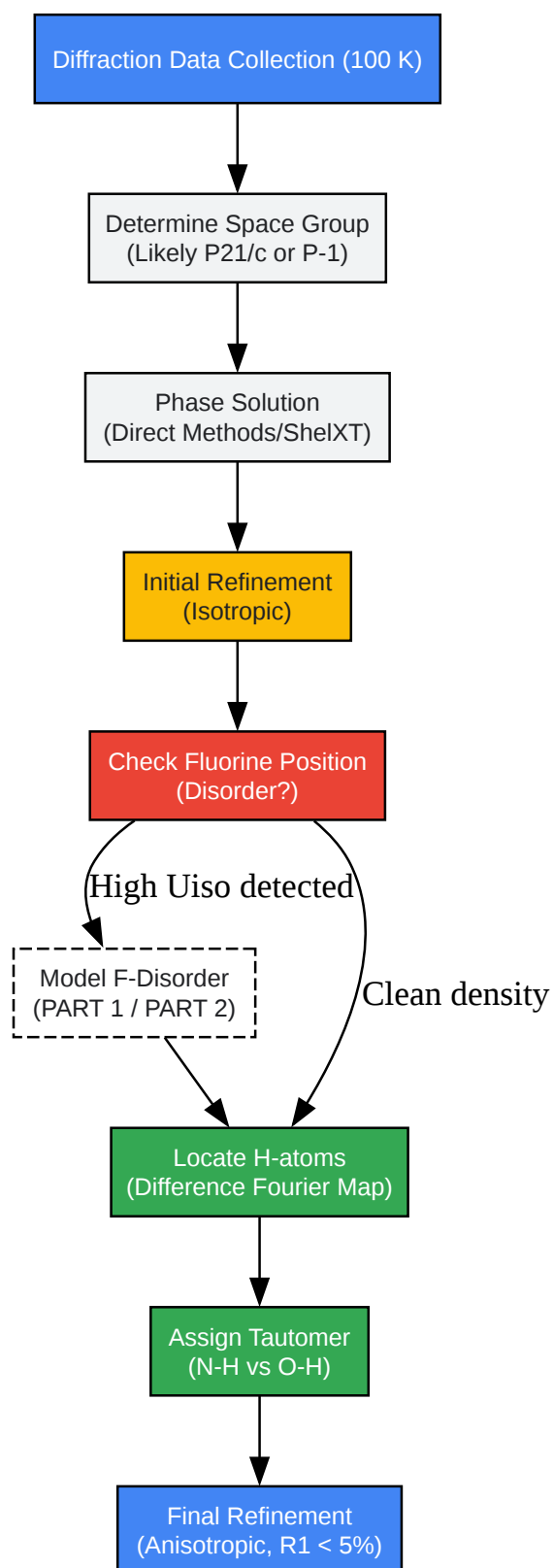

[Click to download full resolution via product page](#)

Caption: Decision tree for X-ray structure solution of fluorinated heterocycles, emphasizing disorder modeling and tautomer identification.

Structural Analysis: The Core

Once the structure is solved, the analysis must focus on three specific areas that define the compound's utility in drug design.

Tautomeric Confirmation (The "Lactam" Rule)

For 6-fluoro-1(2H)-phthalazinone, the crystal structure almost invariably confirms the Lactam (NH-C=O) tautomer over the Lactim (N=C-OH).

- Diagnostic Bond Lengths:
 - C1=O1: Expect 1.22 – 1.24 Å (Double bond character). If it were C-OH, it would be ~1.35 Å.
 - C1-N2: Expect 1.33 – 1.36 Å (Single bond with partial double bond character due to resonance).
 - N2-N3: Expect 1.37 – 1.38 Å.

The "Fluorine Effect" on Packing

Fluorine is not merely a hydrophobic cap; it is an electronic director.

- C-F
 - H Interactions: Look for short contacts between F6 and aromatic protons (H4, H5, or H8) of neighboring molecules.
 - Distance: < 2.55 Å (Sum of van der Waals radii).
 - Significance: These weak "hydrogen bonds" often chain molecules into 1D tapes, increasing melting point and lattice energy.
- F

F Contacts: In highly fluorinated environments, Type I (symmetrical) or Type II (L-shaped) F...F interactions may occur. For mono-fluorinated phthalazines, these are rare; F usually seeks H-donors.

Supramolecular Synthons

The dominant packing motif for phthalazinones is the Centrosymmetric Dimer (

-).
- Mechanism: Two molecules pair up via hydrogen bonds.
 - Graph Set Notation: (Ring, 2 donors, 2 acceptors, 8 atoms in the loop).
 - Pharma Implication: This dimer is extremely stable and non-polar, often limiting aqueous solubility. Disrupting this dimer (e.g., by introducing a bulky group at N2) is a common strategy to improve solubility.

Interaction Map & Logical Causality

The following diagram illustrates how the atomic features of **6-fluorophthalazine** translate into macroscopic crystal properties.

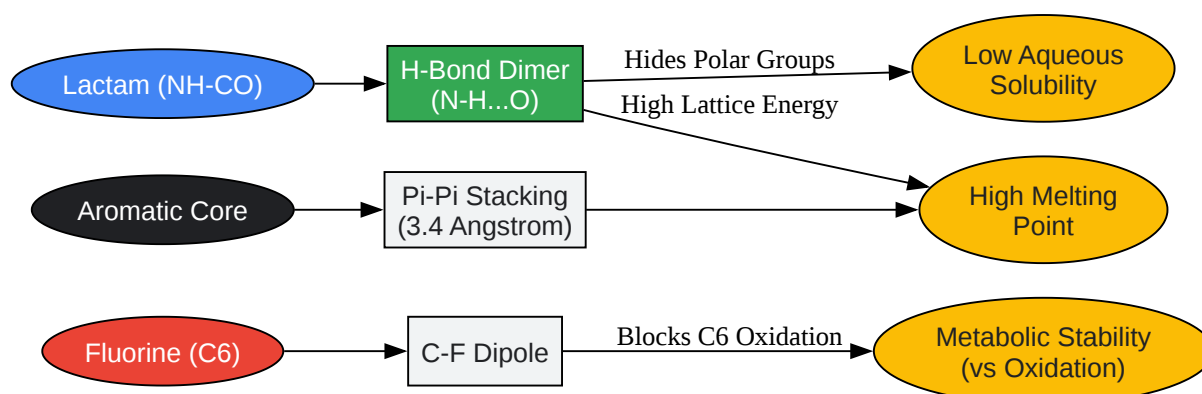

[Click to download full resolution via product page](#)

Caption: Causal map linking the **6-fluorophthalazine** molecular features to crystal packing forces and physicochemical properties.

References

- Cambridge Crystallographic Data Centre (CCDC). Crystal Structure of 1(2H)-Phthalazinone (Analogous Core). CSD Entry: 654943.[1] [Link](#)
- G. R. Desiraju. Hydrogen Bridges in Crystal Engineering: Interactions without Borders. Accounts of Chemical Research. [Link](#)
- H. J. Bohm, et al. Fluorine in Medicinal Chemistry. ChemBioChem. [Link](#)
- PubChem. 6-Fluoro-1(2H)-phthalazinone Compound Summary. [Link](#)

Need Custom Synthesis?

BenchChem offers custom synthesis for rare earth carbides and specific isotopic labeling.

Email: info@benchchem.com or [Request Quote Online](#).

Sources

- 1. 1(2H)-Phthalazinone | C₈H₆N₂O | CID 8394 - PubChem [pubchem.ncbi.nlm.nih.gov]
- To cite this document: BenchChem. [Technical Guide: 6-Fluorophthalazine Crystal Structure Analysis]. BenchChem, [2026]. [Online PDF]. Available at: [<https://www.benchchem.com/product/b13010646/docs#technical-guide-6-fluorophthalazine-crystal-structure-analysis>]

Disclaimer & Data Validity:

The information provided in this document is for Research Use Only (RUO) and is strictly not intended for diagnostic or therapeutic procedures. While BenchChem strives to provide accurate protocols, we make no warranties, express or implied, regarding the fitness of this product for every specific experimental setup.

Technical Support: The protocols provided are for reference purposes. Unsure if this reagent suits your experiment?

Need Industrial/Bulk Grade? [Request Custom Synthesis Quote](#)

BenchChem

Our mission is to be the trusted global source of essential and advanced chemicals, empowering scientists and researchers to drive progress in science and industry.

Contact

Address: 3281 E Guasti Rd
Ontario, CA 91761, United States
Phone: (601) 213-4426
Email: info@benchchem.com

[Contact our Ph.D. Support Team for a compatibility check](#)