

# Technical Guide: Stabilizing Aminooxazoles During Workup & Isolation[1]

**Author:** BenchChem Technical Support Team. **Date:** April 2026

## Compound of Interest

Compound Name: 5-(5-Bromo-2-methoxyphenyl)oxazol-2-amine

Cat. No.: B13009831

[Get Quote](#)

## Executive Summary

Aminooxazoles are deceptively stable in their ground state but exhibit significant instability during workup due to two synergistic failure modes: oxidative polymerization (driven by the electron-rich amine moiety) and photo-induced ring opening (driven by UV susceptibility). Unlike their thiazole counterparts, aminooxazoles lack the sulfur atom but possess a higher electron density on the ring nitrogen, making them prone to formation of N-oxides and subsequent rearrangement into nitrile ylides or polymerized tars when exposed to atmospheric oxygen and light under acidic conditions.[1]

This guide provides a self-validating workflow to arrest these degradation pathways.

## Section 1: Diagnostic Troubleshooting (Q&A)

Q1: My reaction mixture was clear, but it turned dark brown/black immediately upon rotary evaporation. What happened? Diagnosis: You likely triggered oxidative polymerization. Mechanism: The removal of solvent increases the concentration of the aminooxazole. In the presence of atmospheric oxygen and trace metal impurities (often from reagents), the electron-rich amino group undergoes single-electron oxidation to form a radical cation. This species

rapidly polymerizes or reacts with oxygen to form quinoidal imines, resulting in the characteristic "tar" formation.[1] Immediate Fix:

- Stop evaporation. Backfill with Argon immediately.
- Add an antioxidant: Trace amounts of BHT (Butylated hydroxytoluene) or Ascorbic acid can scavenge radical initiators.[1]
- Switch to Lyophilization: If the solvent is aqueous/dioxane, freeze-drying removes oxygen stress associated with heating.[1]

Q2: I lost >50% of my mass after flash chromatography on silica gel. The NMR of the crude was clean. Diagnosis: Acid-catalyzed ring opening and irreversible adsorption. Mechanism: Silica gel is slightly acidic (pH 4–5).[1] Aminooxazoles are basic (pKa ~4–5 for the conjugate acid). They protonate on the silica surface. While the oxazole ring is generally robust, the protonated 2-amino form is susceptible to nucleophilic attack (by water in the silica) or ring opening to form acyclic nitriles/amides. Furthermore, the protonated species binds irreversibly to silanols.[1] Corrective Protocol:

- Pre-treat Silica: Flush the column with 1% Triethylamine (TEA) in hexanes before loading.
- Switch Stationary Phase: Use Basic Alumina (Activity Grade III) or neutral alumina.[1] This is the "Gold Standard" for aminooxazole purification.

Q3: My product degrades even when stored in the freezer under nitrogen.

Diagnosis: Photochemical instability. Mechanism: 2-Aminooxazoles have a distinct UV absorption profile that overlaps with ambient lab lighting. Excitation leads to a conical intersection where the C-O bond cleaves, rearranging the molecule into a reactive nitrile ylide or imidoyleketene.[1] These intermediates then hydrolyze or polymerize. Corrective Protocol:

- Amber Glassware: Mandatory for all storage and workup steps.
- Foil Wrapping: Wrap columns and rotovap flasks in aluminum foil.

## Section 2: The "Shielded" Workup Protocol

This protocol is designed to eliminate the three vectors of decomposition: Oxygen, Acidity, and Light.<sup>[1]</sup>

## Reagents & Materials

- Quench Buffer: Saturated  $\text{NaHCO}_3$  or Phosphate Buffer (pH 7.5–8.0).<sup>[1]</sup> Never quench with acid.<sup>[1]</sup>
- Extraction Solvent: Degassed Ethyl Acetate or DCM (Sparged with Ar for 15 mins).
- Drying Agent: Sodium Sulfate ( $\text{Na}_2\text{SO}_4$ ) - Avoid Magnesium Sulfate (Lewis acidic character can catalyze degradation).
- Stabilizer: 0.1% Triethylamine (TEA) added to all organic solvents.<sup>[1]</sup>

## Step-by-Step Workflow

- Deoxygenation (The "Spurge" Step): Before quenching, spurge the reaction mixture with Argon for 5 minutes.<sup>[1]</sup> Ensure the quench buffer is also degassed.
- The "Dark" Extraction:
  - Perform extraction in a separatory funnel wrapped in foil or under dim light.
  - Critical Check: Monitor the pH of the aqueous layer. It must remain basic (pH > 8).<sup>[1]</sup> If the reaction was acidic, neutralize with cold sat.<sup>[1]</sup>  $\text{NaHCO}_3$  before extraction.
  - Why? Protonation of the oxazole nitrogen lowers the oxidation potential and accelerates decomposition.
- Filtration & Evaporation:
  - Filter the drying agent under an inverted funnel flowing with Argon.
  - Rotary Evaporation: Do not exceed 35°C. Backfill the rotovap with Nitrogen/Argon, not air.<sup>[1]</sup>
- Purification (The "Buffered" Column):

- Method A (Preferred): Basic Alumina column using EtOAc/Hexane.[1]
- Method B (If Silica is necessary): Slurry pack silica in solvent containing 1% TEA.[1] Run the column with 0.5% TEA in the mobile phase.

## Section 3: Mechanistic Visualization

The following diagram illustrates the divergent degradation pathways of aminooxazoles during workup and how specific interventions block them.

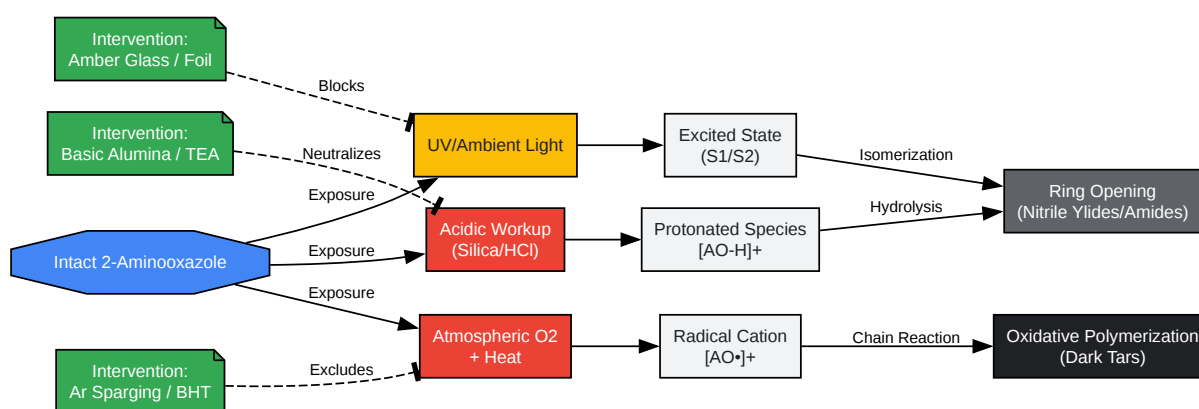

[Click to download full resolution via product page](#)

Figure 1: Degradation pathways of 2-aminooxazoles showing the three primary vectors (Acid, Light, Oxygen) and the targeted interventions required to maintain structural integrity.[1]

## Section 4: Comparative Stability Data

The table below summarizes the stability of 2-aminooxazoles under various workup conditions, highlighting the necessity of the "Shielded" protocol.

Condition	Primary Degradation Mode	Observed Result	Recovery Yield (Normalized)
Standard Silica Column	Acid-catalyzed adsorption/hydrolysis	Streaking, mass loss	40–50%
Ambient Light Exposure (24h)	Photochemical ring opening	Yellowing of solid	75%
Aerobic Evaporation (40°C)	Oxidative polymerization	Dark brown oil/tar	60%
Shielded Protocol	None (Pathways blocked)	White/Off-white solid	>92%

## References

- 2-Aminooxazole as a Novel Privileged Scaffold in Antitubercular Medicinal Chemistry Source: ACS Journal of Medicinal Chemistry Context: Discusses the synthesis and bioisosteric replacement of thiazoles with oxazoles, highlighting the improved metabolic stability but distinct chemical handling requirements. [1]
- Photochemistry of 2-Aminooxazole: A Matrix-Isolation and Computational Study Source: Royal Society of Chemistry (PCCP) Context: Defines the mechanism of UV-induced ring opening to nitrile ylides, validating the requirement for light protection.
- Review on Chemistry of Oxazole Derivatives Source: Taylor & Francis Online Context: Provides a comprehensive overview of oxazole reactivity, including electrophilic substitution and oxidation susceptibility.[1][2] [1]
- Synthesis of Various 2-Aminobenzoxazoles: The Study of Cyclization and Smiles Rearrangement Source: ACS Omega Context: Details synthetic protocols and the stability of amino-oxazole derivatives during cyclization reactions. [1]

### Need Custom Synthesis?

BenchChem offers custom synthesis for rare earth carbides and specific isotopic labeling.

Email: [info@benchchem.com](mailto:info@benchchem.com) or [Request Quote Online](#).

## Sources

- [1. pubs.acs.org \[pubs.acs.org\]](https://pubs.acs.org)
- [2. tandfonline.com \[tandfonline.com\]](https://tandfonline.com)
- To cite this document: BenchChem. [Technical Guide: Stabilizing Aminooxazoles During Workup & Isolation[1]]. BenchChem, [2026]. [Online PDF]. Available at: [<https://www.benchchem.com/product/b13009831/docs#technical-guide-stabilizing-aminooxazoles-during-workup-isolation-1>]

---

### Disclaimer & Data Validity:

The information provided in this document is for Research Use Only (RUO) and is strictly not intended for diagnostic or therapeutic procedures. While BenchChem strives to provide accurate protocols, we make no warranties, express or implied, regarding the fitness of this product for every specific experimental setup.

**Technical Support:** The protocols provided are for reference purposes. Unsure if this reagent suits your experiment?

**Need Industrial/Bulk Grade?** [Request Custom Synthesis Quote](#)

## BenchChem

Our mission is to be the trusted global source of essential and advanced chemicals, empowering scientists and researchers to drive progress in science and industry.

### Contact

Address: 3281 E Guasti Rd  
Ontario, CA 91761, United States  
Phone: (601) 213-4426  
Email: [info@benchchem.com](mailto:info@benchchem.com)

[Contact our Ph.D. Support Team for a compatibility check](#)

