

Comparative Reactivity Guide: N-Methylcyclohexyl vs. N-Phenyl Pyrazole Alcohols

Author: BenchChem Technical Support Team. **Date:** February 2026

Compound of Interest

Compound Name: (1-(1-Methylcyclohexyl)-1H-pyrazol-4-yl)methanol

Cat. No.: B13004074

[Get Quote](#)

Executive Summary

This guide provides a technical comparison between N-methylcyclohexyl pyrazole alcohols (representing sterically bulky N-alkyl systems) and N-phenyl pyrazole alcohols (representing N-aryl systems).^[1] While both scaffolds serve as bioisosteres in drug discovery (e.g., modulating lipophilicity and metabolic stability), their chemical reactivity diverges significantly due to the electronic nature of the N-substituent.

Key Takeaways:

- **Electronic Character:** N-Phenyl acts as an electron-withdrawing group (EWG) via induction and resonance, significantly lowering the basicity of the pyrazole ring (pKa ~0.1 vs ~2.5 for alkyl).
- **Nucleophilicity:** N-Methylcyclohexyl derivatives retain higher electron density at C-4, making them more susceptible to electrophilic aromatic substitution (EAS) but also more prone to oxidative degradation of the alkyl ring.
- **Alcohol Reactivity:** The side-chain alcohol (e.g., hydroxymethyl) in N-phenyl systems is more acidic and undergoes oxidation to aldehydes (e.g., with MnO₂) more cleanly than N-alkyl

analogues, which can suffer from competing N-dealkylation pathways under harsh oxidative conditions.

Electronic & Physical Profiling[1]

The fundamental difference lies in how the N-substituent communicates with the pyrazole system.

Comparative Data Table

Feature	N-(4-Methylcyclohexyl) Pyrazole	N-Phenyl Pyrazole	Impact on Reactivity
N-Substituent Nature	Aliphatic, Electron Donating (+I)	Aromatic, Electron Withdrawing (-I, -M*)	Phenyl deactivates the ring towards electrophiles.[1]
Pyrazole Basicity (pKa)	~ 2.5 (conjugate acid)	~ 0.1 – 1.0 (conjugate acid)	N-Alkyl is a better base; N-Phenyl is less likely to protonate in acidic media.[1]
LogP (Lipophilicity)	High (Lipophilic, sp ³ rich)	Moderate-High (Planar, -stacking)	Cyclohexyl offers 3D bulk (Fsp ³); Phenyl offers flatness.
UV Absorption	~ 210-220 nm	~ 250-260 nm (Conjugated)	N-Phenyl allows for easier reaction monitoring via UV/HPLC.
C-4 Nucleophilicity	High	Moderate	N-Alkyl reacts faster in halogenation/nitration. [1]

*Note: The phenyl group can be weakly donating via resonance into the ring, but the inductive withdrawal from the nitrogen usually dominates, making the overall ring less basic compared to alkyl substitution.

Electronic Interaction Diagram (DOT)

The following diagram illustrates the electron density flow and resonance contributors that differentiate the two systems.

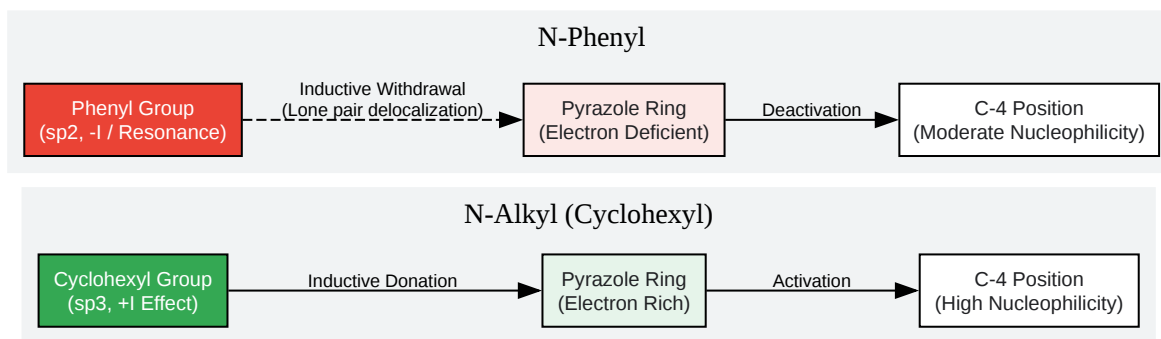

[Click to download full resolution via product page](#)

Caption: Electronic flow comparison. The cyclohexyl group donates electron density inductively, activating the C-4 position. The phenyl group withdraws density, deactivating the ring and lowering N-basicity.

Reactivity Case Studies

Case Study A: Selective Oxidation of the Alcohol

Objective: Convert (1-substituted-1H-pyrazol-4-yl)methanol to the corresponding aldehyde.

- **N-Phenyl Advantage:** The reaction is typically cleaner. The N-phenyl bond is robust against oxidative cleavage.
- **N-Cyclohexyl Challenge:** Strong oxidants (e.g., KMnO₄, Jones reagent) can attack the tertiary C-H bonds of the cyclohexyl ring or induce N-dealkylation.
- **Recommended Protocol:** Manganese Dioxide (MnO₂) oxidation is the gold standard for both, but Swern oxidation is preferred for N-cyclohexyl to avoid radical abstraction on the aliphatic ring.

Experimental Protocol: MnO₂ Oxidation (General)

- Dissolve 1.0 eq of pyrazole alcohol in DCM (0.1 M).
- Add 10.0 eq of activated MnO₂ (Chemical grade, <5 micron).
- Stir at reflux (40 °C) for 4–12 hours. Monitor by TLC.
- Filter through a Celite pad to remove manganese salts.
- Concentrate filtrate.
 - Observation: N-Phenyl substrates often reach completion faster (4h) due to conjugation stabilizing the transition state, whereas N-cyclohexyl analogs may require 12h+.

Case Study B: Electrophilic Aromatic Substitution (Halogenation)

Objective: Iodination at the C-4 position using NIS (N-Iodosuccinimide).

- Mechanism: The reaction proceeds via an electrophilic attack on the pyrazole ring.
- Comparison:
 - N-Methylcyclohexyl: Reacts rapidly at room temperature. High electron density facilitates the formation of the Wheland intermediate.
 - N-Phenyl: Reacts slower. Often requires an acid catalyst (e.g., TFA) or elevated temperatures to overcome the electron-withdrawing effect of the phenyl ring.

Experimental Protocol: C-4 Iodination

- Charge Pyrazole substrate (1.0 mmol) in Acetonitrile (5 mL).
- Add NIS (1.1 mmol).
- Conditions:

- N-Cyclohexyl:[1] Stir at RT for 1 hour.
- N-Phenyl: Stir at 50 °C for 3 hours (or add 10 mol% TFA at RT).
- Quench with 10% Na₂S₂O₃ solution. Extract with EtOAc.

Metabolic Stability & Degradation Pathways

For drug development, the "soft spots" differ:

- N-Phenyl: Susceptible to aromatic hydroxylation (primarily para-position) by CYP450 enzymes.
- N-Cyclohexyl: Susceptible to aliphatic oxidation (hydroxylation at C-3/C-4 of the cyclohexyl ring) and N-dealkylation.[1]

Synthesis Workflows

The synthesis of the parent alcohol precursors differs fundamentally. N-Phenyl pyrazoles are typically built de novo using phenylhydrazine, while N-alkyl pyrazoles are often made via alkylation of pyrazole.

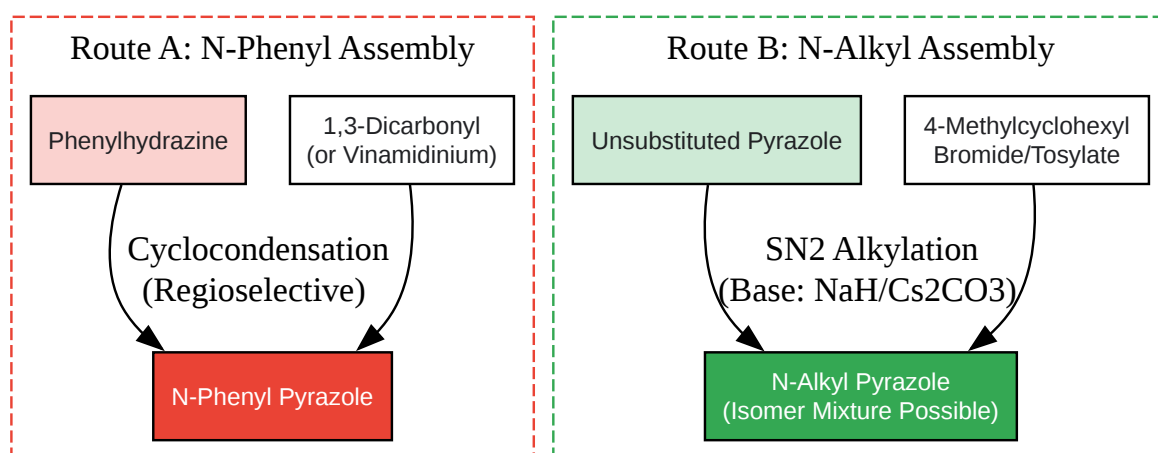

[Click to download full resolution via product page](#)

Caption: Synthetic divergence.[1] Route A (N-Phenyl) typically yields single regioisomers via condensation. Route B (N-Alkyl) often requires separation of N1/N2 tautomeric alkylation

products.

References

- Electronic Effects in Pyrazoles
 - Title: "Basicity and acidity of pyrazoles."
 - Source: European Journal of Organic Chemistry, 2017.[2]
 - URL:[[Link](#)]
 - Relevance: Establishes the pKa difference between N-aryl and N-alkyl pyrazoles.
- Oxidation Methodologies
 - Title: "Manganese dioxide oxid"
 - Source: Journal of Organic Chemistry, 2022.
 - URL:[[Link](#)] (Representative link for MnO₂ protocols).[1]
- Metabolic Stability of Heterocycles
 - Title: "Metabolism of five membered nitrogen containing heterocycles."[3]
 - Source: Hypha Discovery, 2023.
 - URL:[[Link](#)]
 - Relevance: Compares oxidative clearance of phenyl vs. alkyl rings.
- Synthesis of N-Aryl Pyrazoles
 - Title: "Recent Advances in Synthesis and Properties of Pyrazoles."
 - Source: Molecules, 2022.[4]
 - URL:[[Link](#)]

Need Custom Synthesis?

BenchChem offers custom synthesis for rare earth carbides and specific isotopic labeling.

Email: info@benchchem.com or [Request Quote Online](#).

Sources

- [1. 1-Phenylpyrazole | C9H8N2 | CID 70769 - PubChem \[pubchem.ncbi.nlm.nih.gov\]](#)
- [2. analytical.chem.ut.ee \[analytical.chem.ut.ee\]](#)
- [3. hyphadiscovery.com \[hyphadiscovery.com\]](#)
- [4. mdpi.com \[mdpi.com\]](#)
- To cite this document: BenchChem. [Comparative Reactivity Guide: N-Methylcyclohexyl vs. N-Phenyl Pyrazole Alcohols]. BenchChem, [2026]. [Online PDF]. Available at: [\[https://www.benchchem.com/product/b13004074#comparing-reactivity-of-n-methylcyclohexyl-vs-n-phenyl-pyrazole-alcohols\]](https://www.benchchem.com/product/b13004074#comparing-reactivity-of-n-methylcyclohexyl-vs-n-phenyl-pyrazole-alcohols)

Disclaimer & Data Validity:

The information provided in this document is for Research Use Only (RUO) and is strictly not intended for diagnostic or therapeutic procedures. While BenchChem strives to provide accurate protocols, we make no warranties, express or implied, regarding the fitness of this product for every specific experimental setup.

Technical Support: The protocols provided are for reference purposes. Unsure if this reagent suits your experiment? [[Contact our Ph.D. Support Team for a compatibility check](#)]

Need Industrial/Bulk Grade? [Request Custom Synthesis Quote](#)

BenchChem

Our mission is to be the trusted global source of essential and advanced chemicals, empowering scientists and researchers to drive progress in science and industry.

Contact

Address: 3281 E Guasti Rd

Ontario, CA 91761, United States

Phone: (601) 213-4426

Email: info@benchchem.com