

comparative study of turn-inducing properties in proline analogues

Author: BenchChem Technical Support Team. **Date:** April 2026

Compound of Interest

Compound Name: *3-Azabicyclo[3.2.0]heptane-2-carboxylic acid*

Cat. No.: *B13003646*

[Get Quote](#)

Comparative Guide to Turn-Inducing Properties in Proline Analogues: Structural Control and Synthetic Applications

As drug development increasingly pivots toward conformationally restricted peptides and macrocycles, mastering the secondary structure of these molecules is non-negotiable. Canonical L-proline is nature's premier turn-inducer, uniquely possessing a pyrrolidine ring that restricts the

torsion angle and allows for a relatively stable cis-amide bond. However, natural proline is conformationally dynamic (exhibiting endo/exo pucker switching) and can lead to severe aggregation during Solid-Phase Peptide Synthesis (SPPS).

As a Senior Application Scientist, I have evaluated numerous proline analogues designed to overcome these limitations. This guide provides an objective, mechanistic comparison of the turn-inducing properties of key proline analogues—Fluoroprolines, Pseudoprolines, Bicyclic Analogues, and Azaproline—and details self-validating experimental workflows for their application.

Mechanistic Analysis of Proline Analogues

The capacity of an analogue to induce a specific turn (e.g., Polyproline II helices vs. Type VI

-turns) is dictated by how its structural modifications alter two fundamental equilibria: the pyrrolidine ring pucker (C

-endo vs. C

-exo) and the preceding peptide bond conformation (cis vs. trans).

A. Fluoroprolines: Stereoelectronic Tuning

Fluoroprolines leverage the extreme electronegativity of fluorine to dictate conformation without adding significant steric bulk. The causality here is rooted in the stereoelectronic gauche effect[1].

- (4R)-Fluoroproline (4R-Flp): The C–F bond aligns with the amide nitrogen's orbitals, enforcing a C

-exo pucker. This pucker sterically favors the trans-amide bond, effectively stabilizing extended Polyproline II (PPII) helices and destabilizing

-turns[2].

- (4S)-Fluoroproline (4S-Flp): Conversely, 4S-Flp stabilizes the C

-endo pucker, which in turn increases the population of the cis-amide conformer, making it a superior choice for inducing Type VI

-turns[1][2].

B. Pseudoprolines (Pro): Traceless Steric Turn-Inducers

Pseudoprolines (typically oxazolidines or thiazolidines derived from Ser, Thr, or Cys) rely on severe steric clash to dictate conformation. The incorporation of bulky gem-dimethyl groups on the heterocyclic ring forces the preceding amide bond into a >90% cis conformation to relieve steric strain[3]. This introduces a sharp 180° "kink" in the peptide backbone. Crucially, pseudoprolines are "traceless"—they act as powerful turn-inducers to facilitate

macrocyclization and are subsequently hydrolyzed back to the native amino acid during standard acidic cleavage[4].

C. Bicyclic Analogues (OIC) & Azaprolines: Scaffold Rigidity

- Octahydroindole-2-carboxylic acid (OIC): By fusing a cyclohexane ring to the pyrrolidine core, OIC physically locks the ring pucker. This eliminates the entropic penalty of endo/exo switching. Furthermore, the added hydrophobic bulk increases the calculated LogP by ~1.2–1.5 units compared to proline, significantly enhancing membrane permeability and protease resistance[5].
- Azaproline (AzPro): Replacing the C α carbon with a nitrogen atom creates a semicarbazide analogue. The lone-pair repulsion between adjacent nitrogens strongly reinforces a

carbon with a nitrogen atom creates a semicarbazide analogue. The lone-pair repulsion between adjacent nitrogens strongly reinforces a

-VI turn conformation, making it a highly effective, permanent structural mimetic.

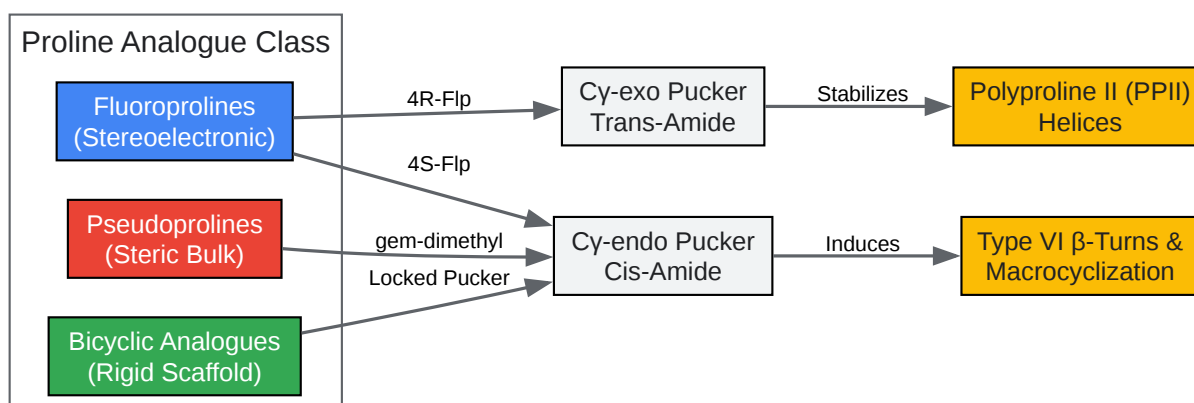

[Click to download full resolution via product page](#)

Logical mapping of proline analogue modifications to secondary structure induction.

Quantitative Performance Comparison

The following table synthesizes the conformational and physicochemical properties of these analogues to guide your selection during sequence design.

Analogue	Primary Modification	Preferred Pucker	Cis-Amide Propensity	Key Application in Drug Design
L-Proline	None (Baseline)	Dynamic	Moderate (~5-10%)	General structural turns, native sequences
(4R)-Flp	C stereoelectronic	C -exo	Low (<5%)	PPII helix stabilization, collagen mimetics
(4S)-Flp	C stereoelectronic	C -endo	High (~10-15%)	Type VI -turn stabilization
Pro (Ser/Thr)	gem-dimethyl sterics	C -endo	Very High (>90%)	SPPS de-aggregation, traceless macrocyclization
OIC (Bicyclic)	Fused Cyclohexane	Locked	Moderate-High	LogP enhancement (+1.5), protease stability
Azaproline	N replaces C	C -endo	High	Permanent -VI turn mimicry

Experimental Workflows & Self-Validating Protocols

To ensure reproducibility and scientific integrity, the following protocols are designed as self-validating systems.

Protocol A: Traceless Pseudoproline-Assisted Peptide Macrocyclization

Linear peptides often suffer from intermolecular oligomerization during solution-phase cyclization. By incorporating a pseudoproline, we force a cis-amide kink that brings the N- and C-termini into close spatial proximity, drastically lowering the entropic barrier to cyclization[3].

Step-by-Step Methodology:

- **SPPS Elongation:** Synthesize the linear peptide on a highly acid-sensitive 2-Chlorotrityl chloride (2-CTC) resin. Incorporate a commercially available Fmoc-Xaa-Ser/Thr(pro)-OH dipeptide at the designated turn region.
- **Mild Cleavage:** Cleave the linear peptide from the resin using 1% TFA in DCM (10 mins, 3 cycles). **Causality:** This mild condition severs the peptide-resin bond but preserves the side-chain protecting groups and the critical pseudoproline oxazolidine ring.
- **Solution-Phase Cyclization:** Dissolve the protected linear peptide in DMF at high dilution (1 mM) to favor intramolecular reactions. Add PyBOP (3 eq) and DIPEA (6 eq). Stir for 2 hours.
- **Global Deprotection & Traceless Removal:** Treat the crude cyclized product with a standard cleavage cocktail (95% TFA / 2.5% TIPS / 2.5% HOAc) for 2 hours. **Causality:** The strong acid hydrolyzes the isopropylidene group of the pseudoproline, reverting it to a native Ser/Thr residue[4].

Self-Validation Checkpoint: Analyze an aliquot via LC-MS after Step 3 but before Step 4. The mass must correspond to the cyclized protected peptide plus 40 Da (the mass of the isopropylidene group). Post-deprotection (Step 4) LC-MS must show the exact mass of the native cyclic peptide, proving the turn-inducer was tracelessly removed without side reactions.

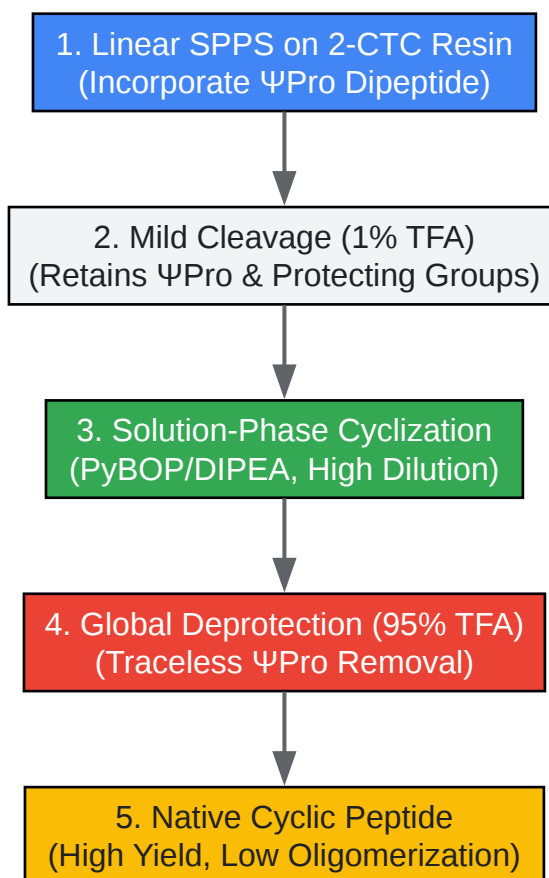

[Click to download full resolution via product page](#)

Workflow for pseudoproline-assisted traceless peptide macrocyclization.

Protocol B: NMR Conformational Analysis of Fluoroprolines

Fluorine (

F) provides a highly sensitive, background-free nucleus for probing the cis/trans equilibrium of fluoroproline-containing peptides[1].

Step-by-Step Methodology:

- Sample Preparation: Dissolve 2-5 mg of the purified fluoroproline peptide in 600 μ L of D

O or CDCl

(depending on solubility).

- 1D

¹F NMR Acquisition: Acquire a 1D

¹F spectrum at 298 K. Causality: The cis and trans isomers of the prolyl amide bond exist in slow exchange on the NMR timescale, yielding two distinct

¹F resonances.

- Quantification: Integrate the two peaks to calculate the thermodynamic equilibrium constant ().

- 2D NOESY Correlation: Acquire a 2D

¹H-

¹H NOESY spectrum. Assign the cis conformer via strong H

(i-1) to H

(i) cross-peaks, and the trans conformer via H

(i-1) to H

(i) cross-peaks.

Self-Validation Checkpoint: To ensure accuracy, the

ratio calculated from the 1D

¹F integration must directly corroborate the relative cross-peak volumes observed in the 2D NOESY spectrum. If the populations do not align, it indicates incomplete

relaxation during the

¹F acquisition, prompting a necessary extension of the

relaxation delay.

References

1.[1] "Biochemistry of fluoroproline: the prospect of making fluorine a bioelement." PMC - NIH. 1 2.[2] Newberry, R.W. and Raines, R.T. "4-Fluoroproline: Conformational Analysis and Effects on the Stability and Folding of Peptides and Proteins." Raines Lab. 2 3.[3] "Peptide Macrocyclization Assisted by Traceless Turn Inducers Derived from Ugi Peptide Ligation with Cleavable and Resin-Linked Amines." ACS Publications. 3 4.[4] "Synthesis of All-L Cyclic Tetrapeptides Using Pseudoproline as Removable Turn Inducers." ResearchGate. 4 5.[5] BenchChem Technical Support Team. "(2R,3aS,7aR)-Octahydro-1H-indole-2-carboxylic acid." Benchchem. 5 6.[6] Kubyskin, V. et al. "Azaproline as a β -turn-inducer residue opposed to proline." ResearchGate. 6

Need Custom Synthesis?

BenchChem offers custom synthesis for rare earth carbides and specific isotopic labeling.

Email: info@benchchem.com or [Request Quote Online](#).

Sources

- 1. Biochemistry of fluoroproline: the prospect of making fluorine a bioelement - PMC [[pmc.ncbi.nlm.nih.gov](https://pubmed.ncbi.nlm.nih.gov/)]
- 2. raineslab.com [raineslab.com]
- 3. pubs.acs.org [pubs.acs.org]
- 4. researchgate.net [researchgate.net]
- 5. (2R,3aS,7aR)-Octahydro-1H-indole-2-carboxylic acid | 145513-92-4 | Benchchem [[benchchem.com](https://www.benchchem.com/)]
- 6. researchgate.net [researchgate.net]
- To cite this document: BenchChem. [comparative study of turn-inducing properties in proline analogues]. BenchChem, [2026]. [Online PDF]. Available at: [<https://www.benchchem.com/product/b13003646/docs#comparative-study-of-turn-inducing-properties-in-proline-analogues>]

Disclaimer & Data Validity:

The information provided in this document is for Research Use Only (RUO) and is strictly not intended for diagnostic or therapeutic procedures. While BenchChem strives to provide

accurate protocols, we make no warranties, express or implied, regarding the fitness of this product for every specific experimental setup.

Technical Support: The protocols provided are for reference purposes. Unsure if this reagent suits your experiment?

Need Industrial/Bulk Grade? [Request Custom Synthesis Quote](#)

BenchChem

Our mission is to be the trusted global source of essential and advanced chemicals, empowering scientists and researchers to drive progress in science and industry.

Contact

Address: 3281 E Guasti Rd

Ontario, CA 91761, United States

Phone: (601) 213-4426

Email: info@benchchem.com

[Contact our Ph.D. Support Team for a compatibility check](#)