

Structural Comparison Guide: 5,7-Dimethylbenzo[d]isothiazole vs. Benzothiophene[1]

Author: BenchChem Technical Support Team. **Date:** April 2026

Compound of Interest

Compound Name: 5,7-Dimethylbenzo[d]isothiazole

Cat. No.: B13000567

[Get Quote](#)

Executive Summary

This guide provides a structural and functional analysis of **5,7-Dimethylbenzo[d]isothiazole** compared to the classical Benzothiophene scaffold.[1] While benzothiophene is a well-established bioisostere of indole and naphthalene found in drugs like Raloxifene and Zileuton, the benzo[d]isothiazole scaffold offers distinct physicochemical advantages, particularly regarding hydrogen bond acceptance (HBA) and metabolic susceptibility.[2]

The 5,7-dimethyl substitution pattern on the benzo[d]isothiazole core introduces critical steric and lipophilic modifications that alter the pharmacophore's volume and binding kinetics.[2] This guide evaluates these two moieties based on electronic distribution, synthetic accessibility, and predicted biological performance.[2][1]

Structural & Electronic Analysis

Core Scaffold Comparison

The fundamental difference lies in the heterocyclic ring fusion.[2][1] Benzothiophene fuses a benzene ring with a thiophene ring, whereas benzo[d]isothiazole fuses benzene with an

isothiazole ring.[2]

- Benzothiophene: Electron-rich, aromatic thiophene ring.[2][1] The sulfur atom acts primarily as a lipophilic spacer and weak H-bond acceptor.[1]
- Benzo[d]isothiazole: The presence of the nitrogen atom (N2) creates a polarized N–S bond. This lowers the aromaticity compared to benzothiophene and makes the ring more electron-deficient.[1] The nitrogen atom serves as a distinct Hydrogen Bond Acceptor (HBA).

Impact of 5,7-Dimethyl Substitution

The addition of methyl groups at the 5- and 7-positions of the benzo-ring exerts two major effects:

- Steric Occlusion: The 7-methyl group is "peri-like" to the heterocycle, potentially twisting the conformation if bulky substituents are present at C3, or simply filling a hydrophobic pocket (e.g., in auxin binding sites).[2][1]
- Metabolic Blocking: C5 and C7 are common sites for oxidative metabolism (hydroxylation) in unsubstituted benzo-fused rings.[1] Methylation blocks these "soft spots," potentially extending half-life ().[2]

Electronic Distribution Diagram (DOT)

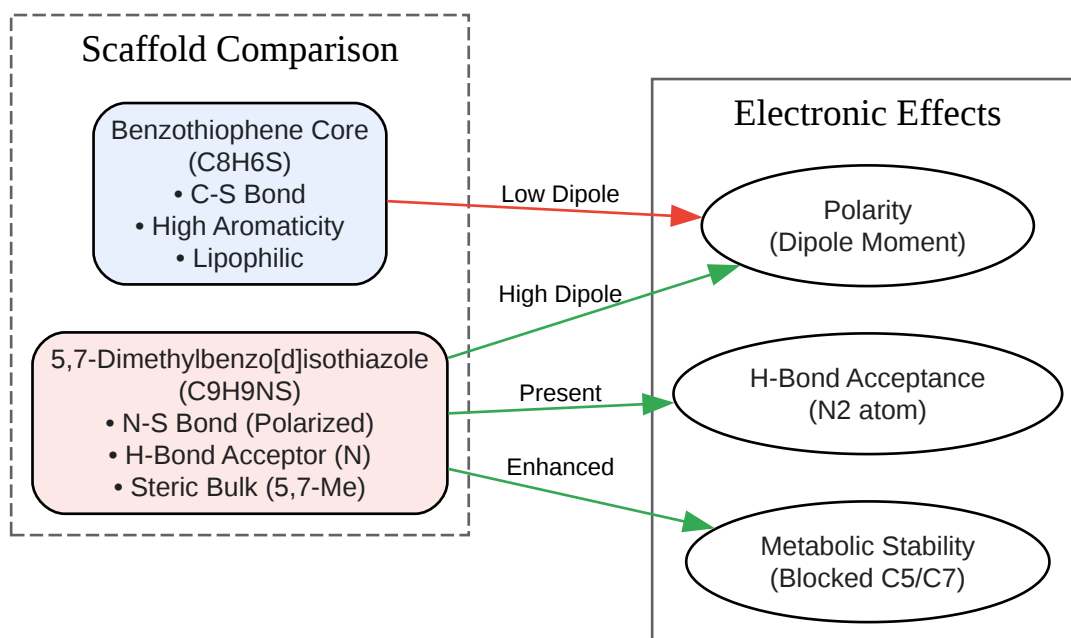

[Click to download full resolution via product page](#)

Figure 1: Structural and functional divergence between the lipophilic benzothiophene and the polarized **5,7-dimethylbenzo[d]isothiazole**.^[2]

Physicochemical Performance Profile

The following table contrasts the predicted physicochemical properties. The 5,7-dimethyl analog is significantly more lipophilic than the unsubstituted isothiazole but retains the polarity advantage over benzothiophene.^{[2][1]}

Feature	Benzothiophene	5,7-Dimethylbenzo[d]isothiazole	Implication for Drug Design
LogP (Lipophilicity)	~3.1	~3.4 (Predicted)	High permeability; 5,7-dimethyls increase LogP by ~1.0 unit vs parent.
H-Bond Acceptors	0 (Weak S)	1 (Strong N)	Isothiazole N can anchor the molecule in the binding pocket via H-bonds.
Electronic Character	Electron-Rich (Nucleophilic)	Electron-Deficient (Electrophilic)	Isothiazole is less prone to oxidation but N-S bond is susceptible to reduction.
Metabolic Liability	S-Oxidation, C-Hydroxylation	N-S Cleavage, Benzylic Oxidation	Methyls block ring hydroxylation but introduce benzylic oxidation risk. ^{[2][1]}
pKa (Conjugate Acid)	< -2 (Very weak base)	~ -0.5 to 0.5	The isothiazole nitrogen is weakly basic, relevant for specific receptor interactions.

Synthetic Accessibility & Protocols

While benzothiophene is commercially ubiquitous, **5,7-dimethylbenzo[d]isothiazole** requires specific construction, typically via the oxidative cyclization of 2-mercaptobenzamides or thionation of 2,4,6-trimethyl-derivatives.^{[2][1]}

Synthesis of 5,7-Dimethylbenzo[d]isothiazole

Mechanism: Intramolecular N–S bond formation.^{[2][1][3][4][5]} Primary Precursor: 2,4,6-Trimethylbenzamide or 2,4,6-Trimethylbenzenethiol derivatives.^{[2][1]}

Protocol: Copper-Catalyzed Oxidative Cyclization

Source: Adapted from recent methodologies for benzo[d]isothiazol-3-ones and isothiazoles [1, 2].

- Reactants:
 - Start with 2,4,6-trimethylbenzamide (1.0 equiv).^{[2][1]}
 - Sulfur Source: Elemental Sulfur () or KSCN.^[1]
 - Catalyst: CuI (10 mol%) or CuBr.^[1]
 - Ligand: 1,10-Phenanthroline (20 mol%).^{[2][1]}
 - Solvent: DMSO or DMF.
 - Base:
(2.0 equiv).^[1]
- Procedure:
 - Step 1: Charge a sealed tube with the amide, sulfur, catalyst, ligand, and base.^{[2][1]}
 - Step 2: Add solvent and stir at 100–120°C under an oxygen atmosphere (balloon) or air for 12–24 hours. The methyl groups at 2,4,6 positions of the starting material (becoming 5,7 in the product) are tolerated, though steric hindrance at the ortho-position (future C7) may slow the reaction rate compared to unsubstituted analogs.^[2]
 - Step 3: Cool to room temperature, dilute with ethyl acetate, and wash with brine.
 - Step 4: Purify via silica gel column chromatography (Hexane/EtOAc gradient).^{[2][1]}

- Validation:
 - ¹H NMR: Look for the disappearance of amide protons and the appearance of the distinct aromatic signals. The C7-Methyl will show a shift due to the proximity of the heteroatom ring.[1]

Synthetic Pathway Diagram (DOT)[1]

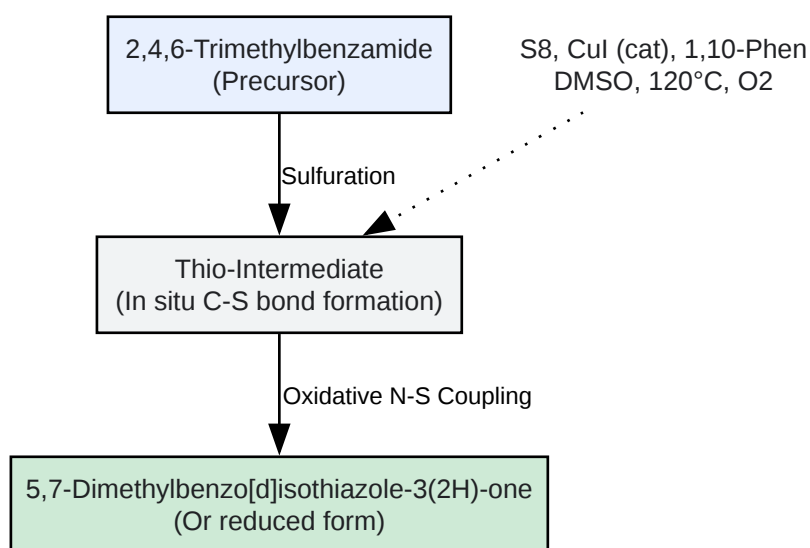

[Click to download full resolution via product page](#)

Figure 2: General synthetic strategy for accessing the **5,7-dimethylbenzo[d]isothiazole** core via copper-catalyzed oxidative cyclization.

Biological Applications & Bioisosterism[2]

Bioisosteric Replacement Strategy

Researchers often swap benzothiophene for benzo[d]isothiazole to:

- Introduce a Hydrogen Bond Acceptor: The Nitrogen at position 2 allows interaction with serine/threonine residues in the binding pocket that benzothiophene cannot engage.[2][1]
- Modulate Potency: In auxin analogs, the benzo[d]isothiazole ring has shown varied activity. The 5,7-dimethyl substitution specifically mimics the hydrophobic bulk of larger indoles or naphthalenes while retaining the unique electronic signature of the isothiazole [3].[2][1]

Case Study: Auxin and 5-HT Activity

- Auxins: Benzothiophene derivatives are classic synthetic auxins.[1] Substitution on the benzo-ring (e.g., 5,7-dichloro or dimethyl) often increases activity by locking the molecule into the hydrophobic "slot" of the TIR1 receptor.[2][1] The **5,7-dimethylbenzo[d]isothiazole** analog is predicted to maintain this hydrophobic fit but with altered electronic repulsion/attraction at the N-S bond region.[2]
- Antiproliferative Agents: Benzo[d]isothiazole hydrazones have shown cytotoxicity against leukemia cell lines (e.g., MT-4).[2][6] The 5,7-dimethyl substitution pattern would likely enhance cell membrane permeability (higher LogP) compared to the parent hydroxylated derivatives [4].[2]

References

- Synthesis of Benzo[d]isothiazoles: An Update.Arkivoc, 2024.[2][1][7] [[Link](#)]
- Copper-Catalyzed Synthesis of Benzo[d]isothiazol-3(2H)-ones.RSC Advances, 2012.[1][3] [[Link](#)]
- Bioisosterism in Drug Design.Journal of Medicinal Chemistry, 2011.[2][1] [[Link](#)]
- Synthesis and antiproliferative activity of benzo[d]isothiazole hydrazones.European Journal of Medicinal Chemistry, 2006.[2][1] [[Link](#)]

Need Custom Synthesis?

BenchChem offers custom synthesis for rare earth carbides and specific isotopic labeling.

Email: info@benchchem.com or [Request Quote Online](#).

Sources

- 1. [researchgate.net](https://www.researchgate.net) [[researchgate.net](https://www.researchgate.net)]
- 2. [rsc.org](https://www.rsc.org) [[rsc.org](https://www.rsc.org)]
- 3. [mdpi.com](https://www.mdpi.com) [[mdpi.com](https://www.mdpi.com)]

- [4. Recent Advances in the Synthesis of Benzo\[d\]isothiazol-3\(2H\)-One and Benzo\[e\]\[1,3\]Thiazin-4-One Derivatives - PMC \[pmc.ncbi.nlm.nih.gov\]](#)
- [5. pdfs.semanticscholar.org \[pdfs.semanticscholar.org\]](#)
- [6. Synthesis and biological evaluation of benzo\[d\]isothiazole, benzothiazole and thiazole Schiff bases - PubMed \[pubmed.ncbi.nlm.nih.gov\]](#)
- [7. liras.kuleuven.be \[liras.kuleuven.be\]](#)
- To cite this document: BenchChem. [Structural Comparison Guide: 5,7-Dimethylbenzo[d]isothiazole vs. Benzothiophene[1]]. BenchChem, [2026]. [Online PDF]. Available at: [<https://www.benchchem.com/product/b13000567/docs#structural-comparison-guide-5-7-dimethylbenzo-d-isothiazole-vs-benzothiophene-1>]

Disclaimer & Data Validity:

The information provided in this document is for Research Use Only (RUO) and is strictly not intended for diagnostic or therapeutic procedures. While BenchChem strives to provide accurate protocols, we make no warranties, express or implied, regarding the fitness of this product for every specific experimental setup.

Technical Support: The protocols provided are for reference purposes. Unsure if this reagent suits your experiment?

Need Industrial/Bulk Grade? [Request Custom Synthesis Quote](#)

BenchChem

Our mission is to be the trusted global source of essential and advanced chemicals, empowering scientists and researchers to drive progress in science and industry.

Contact

Address: 3281 E Guasti Rd
Ontario, CA 91761, United States
Phone: (601) 213-4426
Email: info@benchchem.com

Contact our Ph.D. Support Team for a compatibility check