

Technical Support Center: Maximizing Yield in 2,2'-Bipyrrole Ullmann Coupling

Author: BenchChem Technical Support Team. **Date:** February 2026

Compound of Interest

Compound Name: 2,2'-Bipyrrole

CAS No.: 10087-64-6

Cat. No.: B130514

[Get Quote](#)

Welcome to the technical support resource for the Ullmann homocoupling of 2-halopyrroles to synthesize **2,2'-bipyrroles**. This guide is designed for researchers, medicinal chemists, and materials scientists who utilize this powerful C-C bond-forming reaction and seek to overcome common challenges to improve reaction yield and consistency. **2,2'-Bipyrroles** are crucial building blocks in the synthesis of porphyrinoids, conducting polymers, and various pharmaceuticals, making their efficient synthesis a critical endeavor.^{[1][2][3]}

The classical Ullmann reaction, while a foundational method for biaryl synthesis, has historically been plagued by harsh reaction conditions and inconsistent yields.^{[2][4][5]} However, modern advancements, particularly the introduction of catalytic systems with specific ligands, have significantly broadened its applicability and improved its efficiency.^{[5][6][7]} This guide provides in-depth, experience-driven advice in a question-and-answer format to help you navigate the intricacies of this reaction and achieve optimal results.

Troubleshooting Guide: Common Issues and Solutions

This section addresses the most frequently encountered problems during the Ullmann coupling for **2,2'-bipyrrole** synthesis, offering causative explanations and actionable solutions.

Question 1: My reaction shows low to no conversion of the starting 2-halopyrrole. What are the likely causes and how can I fix it?

Answer:

Low or no product yield is the most common issue and can stem from several factors related to the catalyst, reaction conditions, or reagents.

- Inactive Catalyst: The true active species in most Ullmann couplings is believed to be Cu(I). [8][9] If you are using copper powder (Cu(0)) or a copper(II) salt, the reaction's success depends on the in situ generation of Cu(I).
 - Causality: The surface of copper powder can be passivated by a layer of copper oxides, rendering it inactive. Similarly, Cu(II) salts require reduction to the active Cu(I) state, which may not occur efficiently under all conditions.[8]
 - Solutions:
 - Use a high-purity Cu(I) source: Directly using a fresh, high-purity Cu(I) salt like copper(I) iodide (CuI) or copper(I) bromide (CuBr) is often the most reliable approach.[10]
 - Activate Copper Powder: If using Cu(0), consider pre-treatment. While older methods involved washing with iodine and acid, a simpler and often effective method is to ensure you are using "activated" copper powder or a very fine, high-surface-area powder.
 - Ensure Inert Atmosphere: Oxygen can oxidize the active Cu(I) species. It is crucial to thoroughly degas your solvent and maintain a positive pressure of an inert gas (Argon or Nitrogen) throughout the reaction.[11][12]
- Suboptimal Temperature: Classical Ullmann reactions often require very high temperatures (150-250 °C).[4][9][13]
 - Causality: Significant thermal energy is required to drive the oxidative addition of the halopyrrole to the copper center, especially without a facilitating ligand.
 - Solutions:
 - Incremental Temperature Increase: If you observe no reaction at a given temperature, increase it in increments of 10-20 °C. Monitor for both product formation and potential decomposition of your starting material or product.

- High-Boiling Point Solvents: Use inert, high-boiling aromatic solvents like toluene, xylene, or cumene to achieve the necessary temperatures.[13] While DMF can be used and may allow for lower temperatures, it can sometimes lead to lower yields and complicate workup.[13][14]
- Introduce a Ligand: The most effective way to lower the activation barrier, and thus the required temperature, is to introduce a ligand. (See FAQ section).
- Inappropriate Halide: The reactivity of the 2-halopyrrole follows the order $I > Br > Cl$.
 - Causality: This trend is governed by the C-X bond strength. The weaker C-I bond undergoes oxidative addition to the copper center more readily than the stronger C-Br and C-Cl bonds.
 - Solution: If you are struggling with a 2-chloro or 2-bromopyrrole, consider synthesizing the 2-iodopyrrole intermediate. The increased reactivity often justifies the extra synthetic step. [14]

Question 2: I am observing significant amounts of a dehalogenated pyrrole side product. Why is this happening and what can I do to prevent it?

Answer:

The formation of a dehalogenated (or hydro-dehalogenated) pyrrole is a common side reaction that directly reduces the yield of your desired **2,2'-bipyrrole**.

- Presence of Protic Impurities: Trace amounts of water or other protic species in the reaction mixture are a primary cause.
 - Causality: Protic impurities can protonate organocopper intermediates that form during the catalytic cycle, leading to the release of the dehalogenated pyrrole instead of the coupled product.
 - Solutions:
 - Use Anhydrous Reagents and Solvents: Ensure all solvents are rigorously dried using appropriate methods (e.g., distillation from a drying agent, passage through activated

alumina). Use freshly opened or properly stored anhydrous reagents.

- **Thoroughly Dry Glassware:** All glassware should be oven-dried or flame-dried under vacuum immediately before use to remove adsorbed water.[10]
- **Inert Atmosphere:** A rigorously maintained inert atmosphere helps prevent the introduction of atmospheric moisture.
- **Reaction with Solvent or Ligand:** In some cases, the solvent or ligand can act as a hydrogen source, particularly at high temperatures.
 - **Solution:** Screen alternative solvents. If you suspect the ligand is the source, trying a different class of ligand may be beneficial.

Frequently Asked Questions (FAQs)

Q1: What is the role of a ligand in the Ullmann coupling, and how do I choose one for my 2,2'-bipyrrrole synthesis?

The introduction of ligands has revolutionized the Ullmann reaction, allowing for milder conditions, lower catalyst loadings, and broader substrate scope.[6]

- **Mechanism of Action:** Ligands, typically bidentate N- or O-donors, coordinate to the copper center. This coordination:
 - **Increases Solubility:** It helps to solubilize the copper species in the organic solvent, creating a homogeneous catalytic environment.[6]
 - **Modulates Reactivity:** It alters the electronic properties of the copper center, making it more susceptible to oxidative addition.
 - **Facilitates Reductive Elimination:** It stabilizes the higher oxidation state copper intermediate, promoting the final C-C bond-forming reductive elimination step.[7][9]
- **Common Ligand Classes for Heterocycle Coupling:**
 - **Amino Acids:** L-proline and N,N-dimethylglycine are cost-effective and highly effective ligands.[7][10]

- Diamines: N,N'-dimethylethylenediamine (DMEDA) and related structures are excellent choices.[15]
- Phenanthrolines: 1,10-Phenanthroline and its derivatives are classic and powerful ligands for copper catalysis.[5]
- Selection Strategy: There is no universal ligand. The optimal choice depends on your specific 2-halopyrrole substrate. A good starting point is to screen a representative from each class (e.g., L-proline, DMEDA, 1,10-phenanthroline).

Q2: Which copper source is best: Cu(0), Cu(I), or Cu(II)?

While various copper sources can be used, Cu(I) salts are generally preferred for modern, ligand-assisted Ullmann couplings.[6][8]

Copper Source	Advantages	Disadvantages
Cu(I) Salts (e.g., CuI, CuBr)	Directly provides the active catalytic species.[8] Generally gives the best and most reproducible results.[6]	Can be more expensive than copper powder; should be high purity.
Cu(0) (Copper Powder/Bronze)	Inexpensive.	Activity can be highly variable depending on purity, particle size, and surface oxidation.[8] [13] Often requires very high temperatures.
Cu(II) Salts (e.g., CuCl ₂ , CuO)	Stable and easy to handle.	Requires in situ reduction to Cu(I), which may not be efficient and can depend on other reaction components (e.g., solvent, nucleophiles).[8]

Recommendation: For developing a robust and reproducible protocol, start with a high-purity Cu(I) source like CuI.

Q3: What is the effect of substituents on the pyrrole ring?

Substituents can have a significant electronic and steric impact on the reaction's success.

- **Electron-Withdrawing Groups (EWGs):** Groups like esters (-COOR) or carbonyls at the 5-position can increase the reactivity of the 2-halopyrrole towards oxidative addition.^[14] This can be beneficial, often leading to higher yields under milder conditions.
- **N-H vs. N-Protected Pyrroles:** An unprotected N-H group can act as a nucleophile and potentially coordinate to the copper catalyst, leading to side reactions or catalyst inhibition. While many couplings work with N-H pyrroles, installing a protecting group like Boc (tert-butoxycarbonyl) can prevent these issues and improve solubility.^[13] The protecting group can be removed in a subsequent step.

Visualizing the Process

Generalized Catalytic Cycle

The following diagram illustrates the generally accepted mechanism for a ligand-assisted Ullmann homocoupling reaction. The cycle begins with the active Cu(I) species, which undergoes sequential oxidative additions and a final reductive elimination to form the C-C bond.

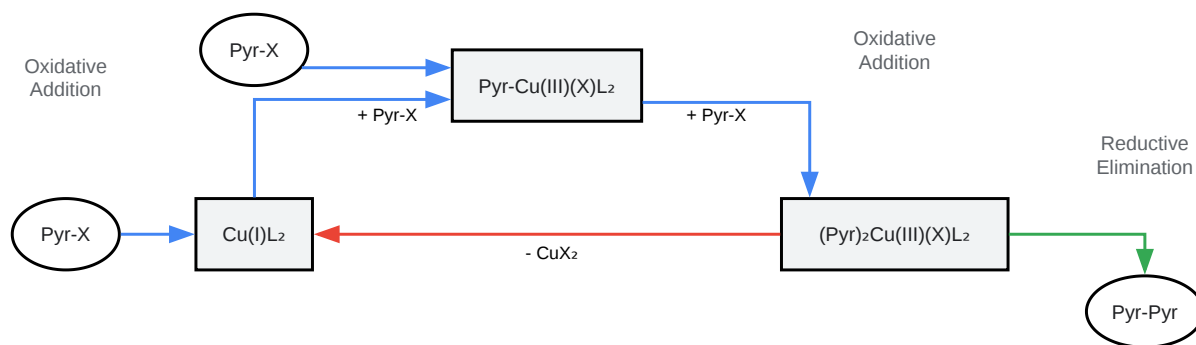

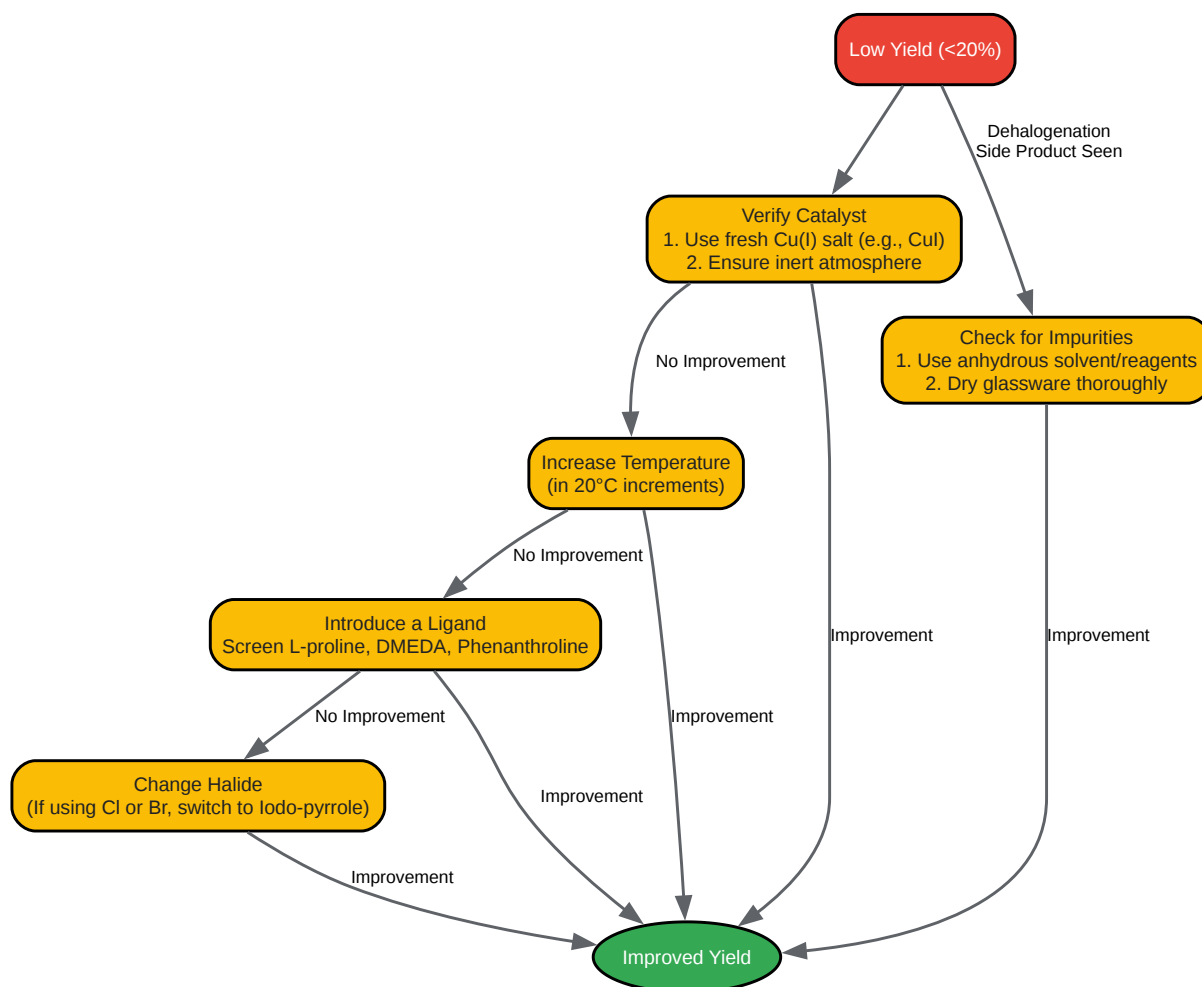

[Click to download full resolution via product page](#)

Caption: A decision tree for troubleshooting low-yield reactions.

Reference Experimental Protocol

This protocol provides a robust starting point for the ligand-assisted Ullmann homocoupling of a generic 2-iodo-1-(Boc)-pyrrole. It should be optimized for each specific substrate.

1. Reagents and Materials:

- 2-Iodo-1-(Boc)-pyrrole (1.0 mmol, 1.0 equiv)
- Copper(I) Iodide (CuI) (0.05 mmol, 5 mol%)
- L-Proline (0.2 mmol, 20 mol%)
- Cesium Carbonate (Cs₂CO₃) (2.0 mmol, 2.0 equiv)
- Anhydrous Toluene (5 mL)
- Oven-dried Schlenk flask or sealed reaction vial with a magnetic stir bar
- Inert gas supply (Argon or Nitrogen)

2. Reaction Setup:

- To the oven-dried Schlenk flask, add the 2-iodo-1-(Boc)-pyrrole, CuI, L-Proline, and Cs₂CO₃.
- Seal the flask, then evacuate and backfill with inert gas. Repeat this cycle three times to ensure a completely inert atmosphere.
- Add the anhydrous toluene via syringe.
- Place the flask in a preheated oil bath or heating block set to 110 °C.

3. Reaction Monitoring and Work-up:

- Stir the reaction vigorously at 110 °C. Monitor the reaction progress by taking small aliquots and analyzing them by TLC or GC-MS. The reaction is typically complete within 12-24 hours.
- Once the starting material is consumed, cool the reaction mixture to room temperature.
- Dilute the mixture with ethyl acetate (20 mL) and filter through a pad of Celite® to remove the insoluble copper salts and base. Wash the pad with additional ethyl acetate (10 mL).
- Combine the organic filtrates and wash with water (2 x 15 mL) and then with brine (15 mL).

- Dry the organic layer over anhydrous sodium sulfate (Na_2SO_4), filter, and concentrate under reduced pressure.

4. Purification:

- The crude product can be purified by column chromatography on silica gel, typically using a hexane/ethyl acetate gradient, to afford the pure **2,2'-bipyrrole** product.

References

- High-yielding ullmann reaction for the preparation of bipyroles. (n.d.). Google Patents.
- C. T. Rogers & B. O. Patrick, "Functionalized 2,2'-Bipyrroles: Building Blocks for Pyrrolic Macrocycles," *Molecules*, vol. 20, no. 8, pp. 13837-13879, 2015. Available: [\[Link\]](#)
- Ullmann coupling-An overview. (2025). OperaChem. Retrieved February 7, 2026, from [\[Link\]](#)
- H. Maeda, "**2,2'-Bipyrrole**-Based Porphyrinoids," *Chemical Reviews*, vol. 117, no. 4, pp. 3168-3222, 2017. Available: [\[Link\]](#)
- Ullmann Reaction. (n.d.). BYJU'S. Retrieved February 7, 2026, from [\[Link\]](#)
- Ullmann Reaction. (n.d.). Organic Chemistry Portal. Retrieved February 7, 2026, from [\[Link\]](#)
- F. Monnier & M. Taillefer, "Copper catalysed Ullmann type chemistry: from mechanistic aspects to modern development," *Chemical Society Reviews*, vol. 42, no. 22, pp. 8834-8847, 2013. Available: [\[Link\]](#)
- G. Evano, N. Blanchard, & M. Toumi, "Copper-Mediated Coupling Reactions and Their Applications in Natural Products and Designed Biomolecules Synthesis," *Chemical Reviews*, vol. 108, no. 8, pp. 3054-3131, 2008. Available: [\[Link\]](#)
- S. V. Ley & A. W. Thomas, "Modern Synthetic Methods for Copper-Mediated C(aryl)-O, C(aryl)-N, and C(aryl)-S Bond Formation," *Angewandte Chemie International Edition*, vol. 42, no. 44, pp. 5400-5449, 2003. Available: [\[Link\]](#)
- D. Ma, Q. Cai, & H. Zhang, "L-Proline Promoted Ullmann-Type Coupling Reactions of Aryl Iodides with Indoles, Pyrroles, Imidazoles or Pyrazoles," *Synlett*, no. 13, pp. 2401-2404, 2005. Available: [\[Link\]](#)

- Troubleshooting Ullmann Coupling. (2023, February 20). Reddit. Retrieved February 7, 2026, from [\[Link\]](#)
- S. D. Rychnovsky, "Mechanism of the Ullmann Biaryl Ether Synthesis Catalyzed by Complexes of Anionic Ligands: Evidence for the Reaction of Iodoarenes with Ligated Anionic CuI Intermediates," *Journal of the American Chemical Society*, vol. 131, no. 28, pp. 9945-9957, 2009. Available: [\[Link\]](#)
- Ullmann reaction. (n.d.). In Wikipedia. Retrieved February 7, 2026, from [\[Link\]](#)
- Y. Liu, et al., "CuCl-Catalyzed Ullmann-Type C-N Cross-Coupling Reaction of Carbazoles and 2-Bromopyridine Derivatives," *Synlett*, vol. 25, no. 12, pp. 1675-1678, 2014. Available: [\[Link\]](#)
- H. Maeda, "2,2'-Bipyrrole-Based Porphyrinoids," *Chemical Reviews*, vol. 117, no. 4, pp. 3168-3222, 2017. Available: [\[Link\]](#)
- A. A. G. E. El-Esch, et al., "Reshaping Ullmann Amine Synthesis in Deep Eutectic Solvents: A Mild Approach for Cu-Catalyzed C-N Coupling Reactions With No Additional Ligands," *Frontiers in Chemistry*, vol. 7, p. 731, 2019. Available: [\[Link\]](#)
- J. Casado, et al., "Structures of 2,2'-bipyrroles 1a–c," *Synthetic Metals*, vol. 121, no. 1-3, pp. 1475-1476, 2001. Available: [\[Link\]](#)
- G. Evano, N. Blanchard, & M. Toumi, "CHAPTER 1: Cu-Catalyzed Ullmann-Type C–Heteroatom Bond Formation: The Key Role of Dinucleating Ancillary Ligands," in *The Chemistry of Organocopper Compounds*, Z. Rappoport and I. Marek, Eds. John Wiley & Sons, Ltd, 2009, pp. 1-118.
- S. Goetz, et al., "Ullmann homocoupling of arenediazonium salts in a deep eutectic solvent. Synthetic and mechanistic aspects," *RSC Advances*, vol. 12, no. 41, pp. 26733-26739, 2022. Available: [\[Link\]](#)

Need Custom Synthesis?

BenchChem offers custom synthesis for rare earth carbides and specific isotopic labeling.

Email: info@benchchem.com or [Request Quote Online](#).

Sources

- [1. 2,2'-Bipyrrrole-Based Porphyrinoids - PubMed \[pubmed.ncbi.nlm.nih.gov\]](#)
- [2. Ullmann reaction - Wikipedia \[en.wikipedia.org\]](#)
- [3. researchgate.net \[researchgate.net\]](#)
- [4. byjus.com \[byjus.com\]](#)
- [5. pubs.acs.org \[pubs.acs.org\]](#)
- [6. pubs.rsc.org \[pubs.rsc.org\]](#)
- [7. researchgate.net \[researchgate.net\]](#)
- [8. Ullmann coupling-An overview - operachem \[operachem.com\]](#)
- [9. Ullmann Reaction \[organic-chemistry.org\]](#)
- [10. pdf.benchchem.com \[pdf.benchchem.com\]](#)
- [11. reddit.com \[reddit.com\]](#)
- [12. Ullmann homocoupling of arenediazonium salts in a deep eutectic solvent. Synthetic and mechanistic aspects - PMC \[pmc.ncbi.nlm.nih.gov\]](#)
- [13. US5756724A - High-yielding ullmann reaction for the preparation of bipyrrroles - Google Patents \[patents.google.com\]](#)
- [14. Functionalized 2,2'-Bipyrrroles: Building Blocks for Pyrrolic Macrocycles - PMC \[pmc.ncbi.nlm.nih.gov\]](#)
- [15. RECENT SYNTHETIC DEVELOPMENTS AND APPLICATIONS OF THE ULLMANN REACTION. A REVIEW - PMC \[pmc.ncbi.nlm.nih.gov\]](#)
- To cite this document: BenchChem. [Technical Support Center: Maximizing Yield in 2,2'-Bipyrrrole Ullmann Coupling]. BenchChem, [2026]. [Online PDF]. Available at: [\[https://www.benchchem.com/product/b130514#improving-yield-in-2-2-bipyrrrole-ullmann-coupling\]](https://www.benchchem.com/product/b130514#improving-yield-in-2-2-bipyrrrole-ullmann-coupling)

Disclaimer & Data Validity:

The information provided in this document is for Research Use Only (RUO) and is strictly not intended for diagnostic or therapeutic procedures. While BenchChem strives to provide accurate protocols, we make no warranties, express or implied, regarding the fitness of this product for every specific experimental setup.

Technical Support: The protocols provided are for reference purposes. Unsure if this reagent suits your experiment? [[Contact our Ph.D. Support Team for a compatibility check](#)]

Need Industrial/Bulk Grade? [Request Custom Synthesis Quote](#)

BenchChem

Our mission is to be the trusted global source of essential and advanced chemicals, empowering scientists and researchers to drive progress in science and industry.

Contact

Address: 3281 E Guasti Rd
Ontario, CA 91761, United States
Phone: (601) 213-4426
Email: info@benchchem.com