

theoretical models of alpha-D-Mannose conformational analysis

Author: BenchChem Technical Support Team. **Date:** May 2026

Compound of Interest

Compound Name: *alpha-D-Mannose*

CAS No.: 135317-04-3

Cat. No.: B013086

[Get Quote](#)

Theoretical Models of -D-Mannose Conformational Analysis

Executive Summary

The conformational plasticity of

-D-mannose is a critical determinant in molecular recognition events, particularly in N-linked glycan processing and lectin binding (e.g., DC-SIGN, ConA). Unlike rigid scaffolds, mannose exhibits a complex free energy landscape defined by the interplay of the anomeric effect, steric repulsion (specifically the axial C2 hydroxyl), and solvation bridges.

This guide provides a rigorous theoretical framework for modeling these dynamics. We move beyond static structures to dynamic ensembles, comparing Molecular Mechanics (GLYCAM06/CHARMM36) with Quantum Mechanical benchmarks (DFT M06-2X), and detailing a self-validating protocol for calculating Free Energy Landscapes (FEL).

Part 1: The Conformational Landscape

To model

-D-mannose, one must quantify three distinct degrees of freedom.

Ring Puckering (vs.)

The pyranose ring is not static. While the

chair is the global minimum in solution, the

inverted chair and

skew-boat are biologically relevant high-energy states (often transition states in mannosidase catalysis).

- Metric: Cremer-Pople Coordinates (

).

- Barrier: The transition typically requires crossing a 10–15 kcal/mol barrier, inaccessible to standard unbiased Molecular Dynamics (MD).

The Hydroxymethyl Rotor (Angle)

The C5–C6 bond rotation determines the orientation of the O6 hydroxyl.

- Rotamers: Gauche-gauche (

), gauche-trans (

), and trans-gauche (

).

- Mannose Specificity: Unlike glucose,

-D-mannose strongly disfavors the

conformation due to the "syn-diaxial like" repulsion between O4 and O6. The equilibrium is dominated by

and

, stabilized by specific water bridges.

The Anomeric Effect

The preference for the electronegative substituent at C1 to adopt an axial orientation (stabilized by

hyperconjugation) is maximized in

-D-mannose. Theoretical models that fail to account for orbital overlap (standard force fields use empirical terms) often underestimate this stabilization.

Part 2: Theoretical Frameworks

Force Field Selection: GLYCAM06 vs. CHARMM36

Feature	GLYCAM06 (AMBER)	CHARMM36	Recommendation
Philosophy	Parameterized specifically for carbohydrates using QM (B3LYP) rotamer profiles.	General biomolecular force field; carbohydrate parameters optimized via osmotic pressure data.[3][4]	GLYCAM06 for pure glycan dynamics.[4]
Anomeric Handling	Explicit torsion terms derived from QM energy surfaces of minimal fragments.	Uses specific Lennard-Jones (LJ) adjustments to reproduce hydration energies.	CHARMM36 if modeling Glycan-Protein complexes (better protein integration).
Solvent Model	TIP3P (Standard), OPC (High Accuracy).	TIP3P modified (CHARMM-specific).	Use OPC with GLYCAM for best density/viscosity matching.
Weakness	Can over-stabilize hydrogen bonds in vacuum; requires explicit solvent.	Historically underestimated hydration free energy (fixed in recent updates).	Always use Explicit Solvent.

Quantum Mechanical Benchmarking

For examining transition states (e.g., ring inversion), Force Fields are insufficient.

- Recommended Level of Theory: M06-2X/6-311++G(d,p).
 - Why: The M06-2X functional captures dispersion interactions better than B3LYP, which is crucial for weak CH- or CH-O interactions in sugars.
 - Solvation: Use SMD (Solvation Model based on Density) with water parameters.

Part 3: Computational Protocol (Step-by-Step)

This protocol describes the generation of a Free Energy Landscape (FEL) for

-D-mannose ring puckering using Well-Tempered Metadynamics.

Phase 1: System Setup & Equilibration

- Structure Generation:
 - Build

-D-mannose in the

conformation using the GLYCAM-Web builder or LEaP (AmberTools).
 - Topology: Apply GLYCAM_06j force field parameters.
- Solvation:
 - Solvate in a cubic box of OPC water (Optimal Point Charge) with a 12 Å buffer.
 - Why OPC? It reproduces the dielectric constant and diffusion properties of water better than TIP3P, critical for glycan hydrodynamics.
- Minimization:
 - 5000 steps steepest descent + 5000 steps conjugate gradient.
- Thermalization (NVT):
 - Heat to 300K over 100 ps using a Langevin thermostat (ps).
 - Constraint: Apply weak restraints (10 kcal/mol·Å) on solute heavy atoms.

- Pressurization (NPT):
 - Equilibrate density for 1 ns at 1 bar using a Berendsen or Monte Carlo barostat. Release restraints.

Phase 2: Enhanced Sampling (Metadynamics)

Standard MD will stay trapped in

. We must bias the simulation.

- Collective Variables (CVs):
 - Define the Cremer-Pople puckering coordinates

and

as CVs.[2]
 - Implementation: Use PLUMED interfaced with AMBER/GROMACS.
- Bias Deposition:
 - Height: 1.2 kJ/mol.
 - Sigma: 0.35 rad (for angular CVs).
 - Pace: Deposit Gaussians every 500 steps.
 - Bias Factor: 10 (Well-Tempered mode to allow convergence).
- Production Run:
 - Run for 50–100 ns. The system will explore

Phase 3: Analysis & Visualization

- Reconstruct Free Energy Surface (FES):

- Sum the deposited hills to generate the 2D FES map ().
- Identify Minima:
 - Global Minimum: (South Pole).
 - Local Minimum: (North Pole).

Part 4: Visualization of Workflows

Figure 1: Computational Workflow for Glycan Analysis

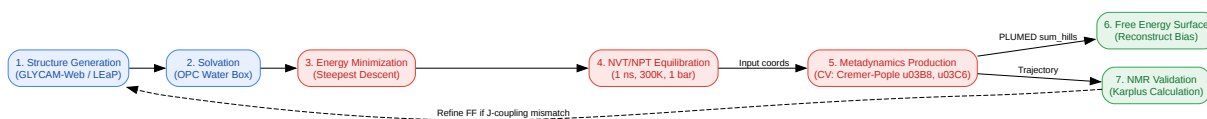

[Click to download full resolution via product page](#)

Caption: End-to-end workflow for calculating and validating the conformational free energy landscape of -D-mannose.

Figure 2: The Conformational Equilibrium Logic

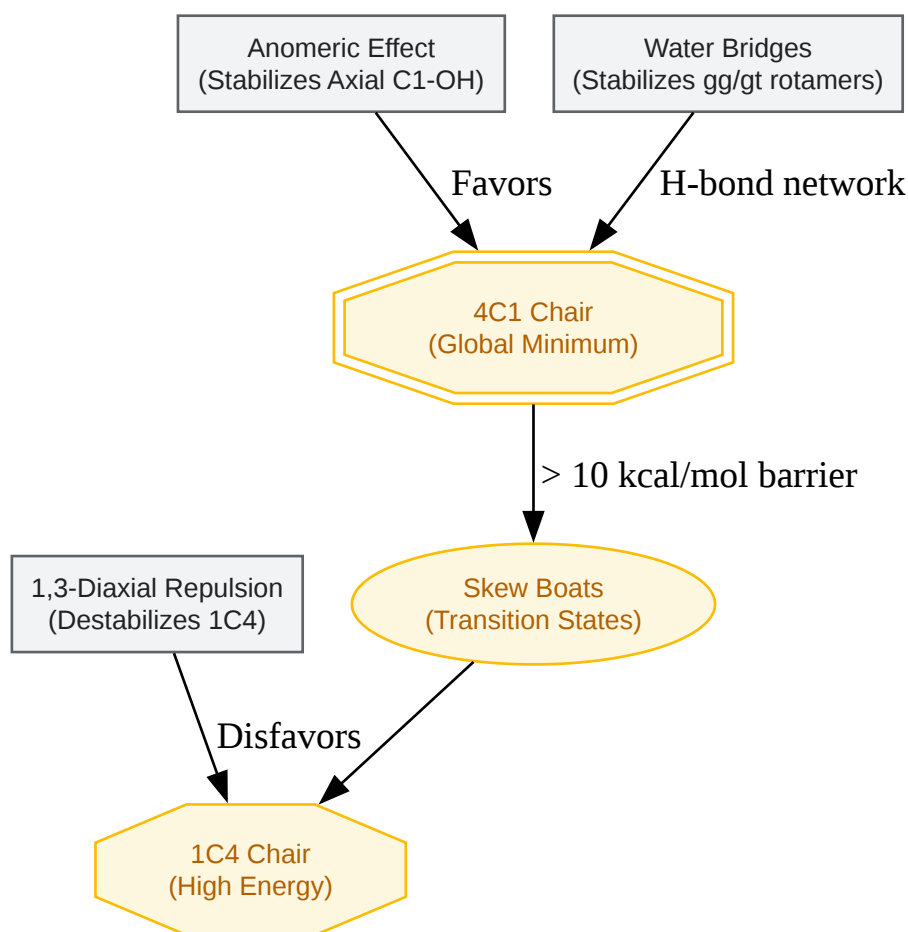

[Click to download full resolution via product page](#)

Caption: Logical map of forces governing the

-D-mannose ring equilibrium. The

state is stabilized by the anomeric effect.

Part 5: Self-Validation (The Karplus Protocol)

To ensure the simulation is physically accurate, you must validate the trajectory against experimental NMR data using the Karplus Equation.

The Logic: If your simulation samples the correct ratio of rotamers (

), the calculated J-coupling constants will match experimental values.

Protocol:

- Extract Trajectory: Save frames every 10 ps from the unbiased equilibrium simulation.
- Calculate Dihedrals: Measure the H5-C5-C6-H6R and H5-C5-C6-H6S dihedral angles () for every frame.
- Apply Generalized Karplus Equation (Haasnoot-Altona):
 - Note: Use parameters optimized for sugars (e.g., Stenutz parameters [1]).
- Average: Compute over the ensemble.
- Compare:
 - Experimental for -D-Man is typically ~2.0 Hz.
 - Experimental is ~5.5 Hz.
 - Pass Criteria: RMSD between Calc and Exp < 0.8 Hz.

References

- Stenutz, R., Carmichael, I., Widmalm, G., & Serianni, A. S. (2002). Hydroxymethyl group conformation in saccharides: structural dependencies of 2JHH, 3JHH, and 2JCH spin-spin coupling constants. *Journal of Organic Chemistry*. [Link](#)
- Kirschner, K. N., et al. (2008).[5] GLYCAM06: A generalizable biomolecular force field. *Carbohydrates*.[\[2\]](#)[\[3\]](#)[\[4\]](#)[\[5\]](#)[\[6\]](#)[\[7\]](#)[\[8\]](#)[\[9\]](#)[\[10\]](#)[\[11\]](#) *Journal of Computational Chemistry*. [Link](#)
- Guvench, O., & MacKerell, A. D. (2008). Comparison of Protein Force Fields for Molecular Dynamics Simulations. *Methods in Molecular Biology*. [Link](#)

- Barducci, A., Bussi, G., & Parrinello, M. (2008). Well-tempered metadynamics: A smoothly converging and tunable free-energy method. *Physical Review Letters*. [Link](#)
- Cremer, D., & Pople, J. A. (1975).[2] General definition of ring puckering coordinates. *Journal of the American Chemical Society*.[12] [Link](#)

Need Custom Synthesis?

BenchChem offers custom synthesis for rare earth carbides and specific isotopic labeling.

Email: info@benchchem.com or [Request Quote Online](#).

Sources

- 1. researchgate.net [researchgate.net]
- 2. Cremer-Pople parameter calculator [enzyme13.bt.a.u-tokyo.ac.jp]
- 3. Optimizing Solute-Solute Interactions in the GLYCAM06 and CHARMM36 Carbohydrate Force Fields Using Osmotic Pressure Measurements - PubMed [pubmed.ncbi.nlm.nih.gov]
- 4. Optimizing Solute-Solute Interactions in the GLYCAM06 and CHARMM36 Carbohydrate Force Fields Using Osmotic Pressure Measurements - PMC [pmc.ncbi.nlm.nih.gov]
- 5. Perspective on computational simulations of glycosaminoglycans - PMC [pmc.ncbi.nlm.nih.gov]
- 6. youtube.com [youtube.com]
- 7. researchgate.net [researchgate.net]
- 8. scispace.com [scispace.com]
- 9. pubs.acs.org [pubs.acs.org]
- 10. Synthesis and conformational analysis of an alpha-D-mannopyranosyl-(1-->2)-alpha-D-mannopyranosyl-(1-->6)-alpha-D-mannopyranose mimic - PubMed [pubmed.ncbi.nlm.nih.gov]
- 11. researchgate.net [researchgate.net]
- 12. Karplus equation - Wikipedia [en.wikipedia.org]
- To cite this document: BenchChem. [theoretical models of alpha-D-Mannose conformational analysis]. BenchChem, [2026]. [Online PDF]. Available at:

[\[https://www.benchchem.com/product/b013086/docs#theoretical-models-of-alpha-d-mannose-conformational-analysis\]](https://www.benchchem.com/product/b013086/docs#theoretical-models-of-alpha-d-mannose-conformational-analysis)

Disclaimer & Data Validity:

The information provided in this document is for Research Use Only (RUO) and is strictly not intended for diagnostic or therapeutic procedures. While BenchChem strives to provide accurate protocols, we make no warranties, express or implied, regarding the fitness of this product for every specific experimental setup.

Technical Support: The protocols provided are for reference purposes. Unsure if this reagent suits your experiment?

Need Industrial/Bulk Grade? [Request Custom Synthesis Quote](#)

BenchChem

Our mission is to be the trusted global source of essential and advanced chemicals, empowering scientists and researchers to drive progress in science and industry.

Contact

Address: 3281 E Guasti Rd
Ontario, CA 91761, United States
Phone: (601) 213-4426
Email: info@benchchem.com

[Contact our Ph.D. Support Team for a compatibility check](#)