

Technical Guide: Precision Analysis of Polymers via p-Tolyl Initiators

Author: BenchChem Technical Support Team. **Date:** May 2026

Compound of Interest

Compound Name: *Methyl 2-bromo-2-(p-tolyl)propanoate*

CAS No.: *1399661-55-2*

Cat. No.: *B12999805*

[Get Quote](#)

Comparative Analysis: p-Tolyl vs. Aliphatic Initiators in ROP

Executive Summary

The Challenge: In polymer chemistry—specifically Ring-Opening Polymerization (ROP) of cyclic esters like Lactide (LA) and

-Caprolactone (

-CL)—accurate determination of molecular weight (

) and end-group fidelity is the cornerstone of structure-property validation. Standard aliphatic initiators (e.g., n-butanol, PEG) suffer from spectral silence in UV-GPC and signal overlap in

¹H NMR, leading to integration errors of up to 15-20% at higher molecular weights (

kDa).

The Solution:p-Tolyl initiators (e.g., 4-methylbenzyl alcohol) function as dual-modal "molecular tags." They provide distinct aromatic resonances for precise NMR integration and a strong chromophore for UV-GPC detection. This guide objectively compares p-tolyl initiators against standard aliphatic alternatives, demonstrating why the former is the superior choice for high-fidelity polymer characterization.

The Analytical Challenge: Why Standard Initiators Fail

When synthesizing polymers for drug delivery or precision engineering, researchers typically rely on two primary metrics:

- NMR: To calculate M_w/M_n via end-group analysis.
- GPC (SEC): To determine Dispersity (M_w/M_n) and weight-average molecular weight (M_w).

The Aliphatic Flaw

- NMR Blind Spots: The protons of an aliphatic initiator (e.g., the α -methylene of n-butanol) often resonate between 3.6–4.2 ppm. This region is crowded with the backbone signals of polyesters (e.g., PCL α -methylene at ~4.06 ppm or PLA methine at ~5.16 ppm). As the polymer chain grows, the initiator signal becomes a "needle in a haystack," making accurate integration impossible.
- GPC Invisibility: Aliphatic backbones (PLA, PCL) and aliphatic initiators are UV-silent. They can only be detected via Refractive Index (RI). This makes it impossible to distinguish between initiated polymer chains and cyclic impurities or non-functionalized chains using a UV detector.

p-Tolyl Initiators: The Mechanism of Precision

p-Tolyl initiators introduce a chemically stable aromatic ring at the

-terminus of the polymer chain. This simple modification resolves the analytical bottlenecks through two distinct mechanisms:

Mechanism A: NMR Signal Isolation

The p-tolyl group provides four aromatic protons that resonate at 7.1–7.2 ppm. This region is completely devoid of signals from aliphatic polyester backbones (which typically appear between 1.0–5.2 ppm).

- Benefit: Zero baseline interference allows for precise integration even at high molecular weights (g/mol).

Mechanism B: UV-GPC Dual Detection

The aromatic ring acts as a built-in UV chromophore (absorbance nm).

- Benefit: By overlaying UV and RI traces, researchers can calculate Initiation Efficiency. If the polymer peak shows a strong RI signal but no UV signal, the chain was not initiated by the p-tolyl group (indicating macrocyclic formation or water initiation).

Comparative Analysis: p-Tolyl vs. Alternatives

The following table contrasts p-Tolyl initiators with common alternatives (Benzyl Alcohol and n-Butanol) in the context of Poly(L-lactide) (PLLA) analysis.

Table 1: Analytical Performance Matrix

| Feature | p-Tolyl Initiator (4-Methylbenzyl alcohol) | Benzyl Alcohol | Aliphatic Initiator (n-Butanol) |
|--------------------------|---|--|--|
| NMR Signal Region | 7.1–7.3 ppm (Aromatic) & 2.3 ppm (Methyl) | 7.3–7.4 ppm (Aromatic) | 0.9, 1.3, 3.6 ppm (Overlaps with backbone) |
| NMR Integration Standard | Internal Validation: Ratio of Aromatic (4H) to Methyl (3H) confirms purity. | Single signal set (5H). No internal ratio check. | None. Relies on backbone integration. |
| Limit (NMR) | High (~30-40 kDa) due to distinct isolation. | High (~30 kDa). | Low (<10 kDa). Signal lost in noise. |
| GPC Detection | Dual (UV + RI). Strong UV signal at 254nm. ^[1] | Dual (UV + RI). ^[1] | RI Only. UV silent. |
| End-Group Fidelity | Verifiable. UV/RI ratio constant across peak. | Verifiable. | Unverifiable. |

Experimental Protocols

Protocol A: Synthesis of p-Tolyl-PLLA

- Reagents: L-Lactide (recrystallized from toluene), 4-Methylbenzyl alcohol (p-Tolyl initiator), Tin(II) 2-ethylhexanoate (), Toluene (anhydrous).
- Conditions: , 110°C, Inert atmosphere.

Step-by-Step Workflow:

- Preparation: In a glovebox, dissolve L-Lactide (1.0 g, 6.94 mmol) and p-Tolyl initiator (9.4 mg, 0.069 mmol) in anhydrous toluene (5 mL).
- Initiation: Add

solution (10 μ L of a 0.1 M stock).
- Polymerization: Seal vessel and heat to 110°C for 12 hours.
- Termination: Quench with 2 drops of wet methanol.
- Purification: Precipitate into cold methanol (

). Filter and dry under vacuum at

for 24 hours.

Protocol B: NMR Analysis (Calculation)

- Instrument: 400 MHz or higher (e.g., Bruker Avance).
- Solvent:

(Chloroform-d).

Calculation Logic:

- Calibrate: Set

residual peak to 7.26 ppm.
- Integrate End-Group: Integrate the p-tolyl aromatic protons (4H) at 7.15 ppm. Set value to 4.00.
- Integrate Backbone: Integrate the PLA methine proton (1H) at 5.16 ppm. Let this area be

.
- Calculate DP (Degree of Polymerization):

- Calculate

:

Protocol C: GPC Analysis (Dual Detection)

- Detectors: Refractive Index (RI) + UV-Vis (set to 254 nm).[\[1\]](#)
- Mobile Phase: THF (HPLC grade).
- Flow Rate: 1.0 mL/min.

Interpretation:

- Normalize both UV and RI signals.
- Perfect Initiation: The UV trace perfectly overlays the RI trace.
- Initiator Efficiency Loss: If a low-MW tail appears in RI but not UV, it indicates non-initiated oligomers or cyclic impurities.

Visualization of Analytical Logic

The following diagram illustrates the self-validating workflow using p-Tolyl initiators.

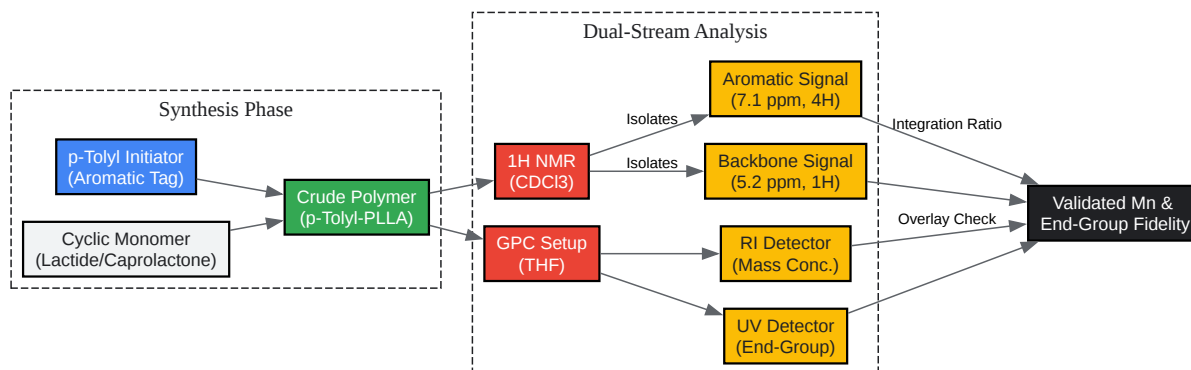

[Click to download full resolution via product page](#)

Caption: Figure 1: Self-Validating Analytical Workflow. The p-tolyl initiator enables two independent validation streams: NMR integration (Aromatic/Backbone ratio) and GPC signal overlay (UV/RI), ensuring high-fidelity characterization.

Critical Considerations & Troubleshooting

The PCL Overlap Warning

While p-tolyl is excellent for PLA, researchers must be cautious with Poly(
-caprolactone) (PCL).

- The Issue: The methyl protons of the p-tolyl group (~2.32 ppm) often overlap with the -methylene protons of the PCL backbone (~2.30 ppm).
- The Fix: Do not use the methyl signal for integration in PCL. Rely exclusively on the aromatic protons at 7.1–7.2 ppm, which remain distinct from the PCL backbone (1.3–4.1 ppm).

Solvent Effects

- CDCl₃: Recommended standard. Excellent solubility for PLA/PCL and clear aromatic separation.
- DMSO-d₆: Avoid if possible. Can cause signal broadening and shift aromatic peaks, complicating integration.

References

- Storey, R. F., & Sherman, J. W. (2002). Kinetics and Mechanism of the Stannous Octoate-Catalyzed Bulk Polymerization of ϵ -Caprolactone. *Macromolecules*.[\[2\]\[3\]\[4\]\[5\]\[6\]\[7\]\[8\] Link](#)
- Save, M., et al. (2002). Controlled Radical Polymerization of Styrene Initiated by p-Tolyl Sulfonyl Chloride. *Polymer*.[\[2\]\[3\]\[4\]\[5\]\[9\]\[6\]\[7\]\[8\]\[10\]\[11\]\[12\] Link](#)
- Malvern Panalytical. (2023). GPC/SEC Detection: UV-Vis vs RI.[Link](#)
- Waters Corporation. (2024). GPC Analysis of Polymers: Detector Selection Guide.[Link](#)
- Polymer Science Learning Center. (2025). NMR Spectroscopy of Polymers.[\[3\]\[4\]\[8\]\[13\]\[14\] University of Southern Mississippi.\[4\] Link](#)

Need Custom Synthesis?

BenchChem offers custom synthesis for rare earth carbides and specific isotopic labeling.

Email: info@benchchem.com or [Request Quote Online](#).

Sources

- [1. chromatographyonline.com](http://1.chromatographyonline.com) [chromatographyonline.com]
- [2. researchgate.net](http://2.researchgate.net) [researchgate.net]
- [3. eng.uc.edu](http://3.eng.uc.edu) [eng.uc.edu]
- [4. api.pageplace.de](http://4.api.pageplace.de) [api.pageplace.de]
- [5. creative-biostructure.com](http://5.creative-biostructure.com) [creative-biostructure.com]

- 6. Aromatic vs. aliphatic linkers: impact on dye loading and stability in oligoglycerol-derived dendronized polymersomes - Polymer Chemistry (RSC Publishing) [pubs.rsc.org]
- 7. pdf.benchchem.com [pdf.benchchem.com]
- 8. Radical ring-opening polymerization of sustainably-derived thionisochromanone - PMC [pubmed.ncbi.nlm.nih.gov]
- 9. archive.lib.cmu.ac.th [archive.lib.cmu.ac.th]
- 10. resolvemass.ca [resolvemass.ca]
- 11. researchgate.net [researchgate.net]
- 12. mdpi.com [mdpi.com]
- 13. End-Group Analysis of Polymer | MtoZ Biolabs [mtoz-biolabs.com]
- 14. Advancing Quantitative ³¹P NMR Spectroscopy for Reliable Thiol Group Analysis - PMC [pubmed.ncbi.nlm.nih.gov]
- To cite this document: BenchChem. [Technical Guide: Precision Analysis of Polymers via p-Tolyl Initiators]. BenchChem, [2026]. [Online PDF]. Available at: [<https://www.benchchem.com/product/b12999805/docs#technical-guide-precision-analysis-of-polymers-via-p-tolyl-initiators>]

Disclaimer & Data Validity:

The information provided in this document is for Research Use Only (RUO) and is strictly not intended for diagnostic or therapeutic procedures. While BenchChem strives to provide accurate protocols, we make no warranties, express or implied, regarding the fitness of this product for every specific experimental setup.

Technical Support: The protocols provided are for reference purposes. Unsure if this reagent suits your experiment?

Need Industrial/Bulk Grade? [Request Custom Synthesis Quote](#)

BenchChem

Our mission is to be the trusted global source of essential and advanced chemicals, empowering scientists and researchers to drive progress in science and industry.

Contact

Address: 3281 E Guasti Rd

Ontario, CA 91761, United States

Phone: (601) 213-4426

Email: info@benchchem.com

[Contact our Ph.D. Support Team for a compatibility check](#)