

Comparative Guide: Mass Spectrometry Fragmentation of Fluoro-Iodo- Dialkoxybenzenes[1]

Author: BenchChem Technical Support Team. **Date:** April 2026

Compound of Interest

Compound Name:	1,5-Diethoxy-2-fluoro-4-iodobenzene
CAS No.:	1208074-88-7
Cat. No.:	B12999772

[Get Quote](#)

Executive Summary

Fluoro-iodo-dialkoxybenzenes represent a critical class of intermediates in the synthesis of advanced functional materials, particularly liquid crystals (LCs) and fluorinated pharmaceuticals. Their structural duality—possessing both a labile iodine atom (excellent for cross-coupling) and a robust fluorine atom (for dielectric anisotropy)—creates a unique mass spectrometric signature.

This guide provides an in-depth technical comparison of the fragmentation behaviors of these compounds against their difluoro- and diiodo- analogs.[1] By understanding the specific C-I bond lability versus C-F bond stability, researchers can optimize structural elucidation workflows and monitor reaction progress with high precision.

Mechanistic Principles: The Halogen Dichotomy

To interpret the mass spectrum of a fluoro-iodo-dialkoxybenzene (e.g., 1-fluoro-4-iodo-2,5-dimethoxybenzene), one must first understand the competing electronic and thermodynamic forces at play.^[1]

The "Fragile" Iodine vs. The "Resilient" Fluorine

The fragmentation is governed by the bond dissociation energies (BDE) of the substituents on the aromatic ring.

- C–I Bond (~65 kcal/mol): The weakest link. Upon electron impact (EI) ionization, the radical cation () rapidly loses the iodine radical (). This creates a dominant phenyl cation species.^[1]
- C–F Bond (~126 kcal/mol): The strongest single bond to carbon. The fluorine atom rarely cleaves in the primary fragmentation stage. It typically remains attached to the aromatic core, serving as a stable "tracer" throughout the degradation pathway.
- Alkoxy Groups (–OR): These groups undergo characteristic -cleavage or alkyl losses.^[1] For methoxy groups, the loss of a methyl radical (, -15 Da) is common. For ethoxy groups, the loss of ethylene (, -28 Da) via a four-membered transition state is favored.^[1]

Isotopic Signatures

Unlike chloro- or bromo- derivatives, Fluorine (

) and Iodine (

) are monoisotopic.^{[1][2]}

- Implication: The molecular ion () will not show the characteristic M+2 isotope clusters seen in Cl/Br compounds. This simplifies the spectrum but removes the "easy" halogen diagnostic tag, making the

fragmentation pattern analysis critical.

Comparative Analysis: Performance & Behavior

We compare the target compound class against its two primary structural analogs used in similar synthetic pathways.

Comparison Matrix: Fragmentation Behaviors

Feature	Fluoro-Iodo-Dialkoxybenzene (Target)	Difluoro-Dialkoxybenzene (Alternative A)	Diiodo-Dialkoxybenzene (Alternative B)[1]
Molecular Ion ()	Moderate Intensity. The C-I bond is weak, leading to partial fragmentation in the source.[1]	High Intensity. The C-F bonds stabilize the aromatic ring; fragmentation is less immediate.	Low / Absent. Both C-I bonds are labile; rapid degradation often depletes the molecular ion.
Primary Fragment	. Loss of Iodine is the exclusive primary pathway.	. Loss of alkyl group (e.g.,) from alkoxy side chain.	and . Sequential loss of both iodines.[1]
Base Peak (Typical)	Often or .[1]	Often or .[1]	Often .
Diagnostic Value	High. The presence of F (stable) and loss of I (labile) confirms the mixed-halogen motif.	Moderate. Hard to distinguish from other stable isomers without NMR.[1]	Low. Rapid loss of both iodines leaves a generic dialkoxy-phenyl core.[1]
C-X Bond Cleavage	Selective. Only C-I breaks; C-F remains.	Resistant. C-F bonds rarely break under standard EI (70 eV). [1]	Promiscuous. Both C-I bonds break easily.[1]

Detailed Fragmentation Pathways

The following diagram illustrates the specific decay cascade for 1-fluoro-4-iodo-2,5-dimethoxybenzene. This pathway is self-validating: the sequential loss of mass corresponds exactly to the specific functional groups present.

Pathway Visualization (Graphviz)

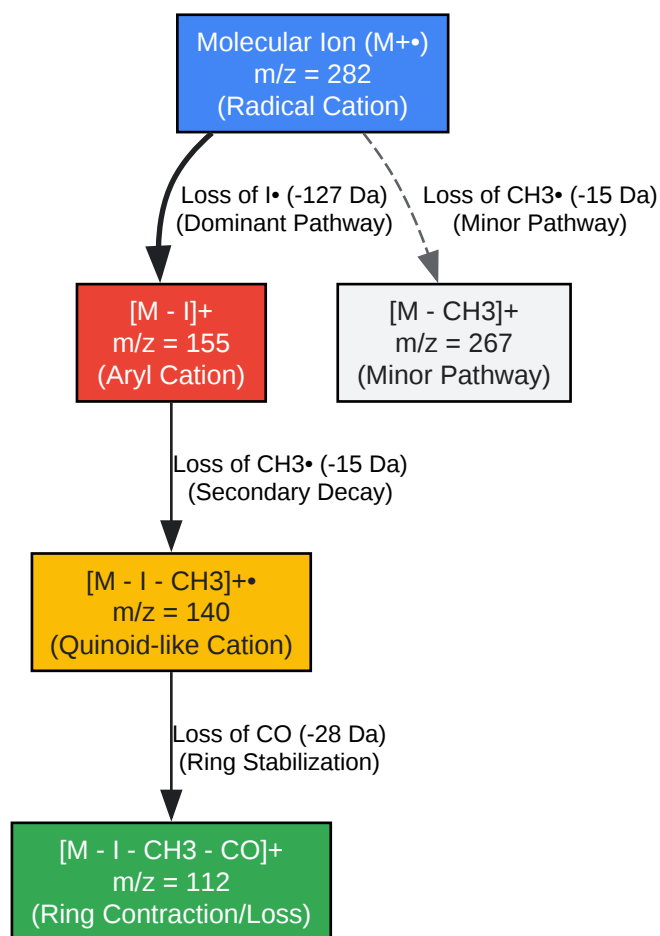

[Click to download full resolution via product page](#)

Figure 1: Predicted fragmentation cascade for 1-fluoro-4-iodo-2,5-dimethoxybenzene under 70 eV Electron Impact (EI).

Pathway Explanation

- Initiation: The molecular ion (m/z 282) is formed.

- **Primary Cleavage (Dominant):** The C-I bond cleaves homolytically. The iodine radical (127 Da) leaves, generating the aryl cation at m/z 155. This is often the Base Peak or close to it.
- **Secondary Cleavage:** The remaining fluorinated dimethoxy-phenyl cation is unstable.^[1] It ejects a methyl radical (-15 Da) from one of the methoxy groups to form a quinoid-like ion at m/z 140.^[1]
- **Tertiary Cleavage:** Expulsion of carbon monoxide (CO, -28 Da) is characteristic of phenols/anisoles, resulting in a fragment at m/z 112.^[1]

Experimental Protocol: Validation Workflow

To reliably characterize these compounds, use the following standardized GC-MS protocol. This method ensures separation of isomers and sufficient energy for diagnostic fragmentation without total molecular obliteration.^[1]

Sample Preparation

- **Solvent:** Dichloromethane (DCM) or Ethyl Acetate (HPLC Grade).^[1] Avoid methanol if transesterification is a risk (though low risk for these ethers).^[1]
- **Concentration:** 10–50 µg/mL (ppm).^[1]
- **Filtration:** 0.2 µm PTFE filter to remove particulate precursors.^[1]

Instrument Parameters (GC-MS)

Parameter	Setting	Rationale
Ionization Source	Electron Impact (EI)	Standard 70 eV provides reproducible spectral libraries (NIST/Wiley compatible).[1]
Source Temp	230 °C	High enough to prevent condensation, low enough to minimize thermal degradation of the C-I bond before ionization.
Column	5% Phenyl-methylpolysiloxane (e.g., DB-5ms, HP-5ms)	Non-polar stationary phase is ideal for halogenated aromatics.[1]
Carrier Gas	Helium, 1.0 mL/min	Constant flow for stable retention times.[1]
Oven Program	60°C (1 min) 20°C/min 300°C (3 min)	Rapid ramp prevents peak broadening; these compounds are semi-volatile.
Mass Range	m/z 40 – 500	Captures the molecular ion and low-mass aromatic fragments.[1]

Data Interpretation Step-by-Step

- Check M+: Look for the molecular ion.[1][3][4][5][6] If it is odd-numbered, check for nitrogen (unlikely here).[1] If even, it fits the C/H/O/Halogen profile.
- Verify Iodine Loss: Calculate

.[1] A strong peak at this value is the "smoking gun" for an iodo-aromatic.[1]
- Verify Fluorine Retention: The fragment

should not lose another 19 Da (F) immediately.[1] If you see

(

), the ring system is likely shattering, but usually, the F remains.

- Confirm Alkoxy: Look for losses of 15 (methyl), 29 (ethyl), or 31 (methoxy) depending on the specific alkyl chain.

References

- NIST Mass Spectrometry Data Center. Benzene, 1-fluoro-2-iodo- Mass Spectrum.[1] National Institute of Standards and Technology.[1]
- Smith, R. M. Understanding Mass Spectra: A Basic Approach.[1] Wiley-Interscience. (General principles of Halogen fragmentation).
- Hird, M. Fluorinated Liquid Crystals: Properties and Applications.[1] Chemical Society Reviews.[1] (Context on synthesis and stability of fluoro-iodo intermediates).
- Gross, J. H. Mass Spectrometry: A Textbook.[1] Springer.[1] (Mechanisms of alkoxybenzene fragmentation and McLafferty rearrangements).
- PubChem. 1-Fluoro-4-iodobenzene Compound Summary. National Library of Medicine.[1]

Need Custom Synthesis?

BenchChem offers custom synthesis for rare earth carbides and specific isotopic labeling.

Email: info@benchchem.com or [Request Quote Online](#).

Sources

- 1. 4-Fluoroiodobenzene | C₆H₄FI | CID 9605 - PubChem [pubchem.ncbi.nlm.nih.gov]
- 2. [scribd.com](https://www.scribd.com) [[scribd.com](https://www.scribd.com)]
- 3. [chemguide.co.uk](https://www.chemguide.co.uk) [[chemguide.co.uk](https://www.chemguide.co.uk)]
- 4. [info.gbiosciences.com](https://www.info.gbiosciences.com) [[info.gbiosciences.com](https://www.info.gbiosciences.com)]

- [5. fiveable.me \[fiveable.me\]](#)
- [6. chem.libretexts.org \[chem.libretexts.org\]](#)
- To cite this document: BenchChem. [Comparative Guide: Mass Spectrometry Fragmentation of Fluoro-Iodo-Dialkoxybenzenes[1]]. BenchChem, [2026]. [Online PDF]. Available at: [<https://www.benchchem.com/product/b12999772/docs#comparative-guide-mass-spectrometry-fragmentation-of-fluoro-iodo-dialkoxybenzenes-1>]

Disclaimer & Data Validity:

The information provided in this document is for Research Use Only (RUO) and is strictly not intended for diagnostic or therapeutic procedures. While BenchChem strives to provide accurate protocols, we make no warranties, express or implied, regarding the fitness of this product for every specific experimental setup.

Technical Support: The protocols provided are for reference purposes. Unsure if this reagent suits your experiment?

Need Industrial/Bulk Grade? [Request Custom Synthesis Quote](#)

BenchChem

Our mission is to be the trusted global source of essential and advanced chemicals, empowering scientists and researchers to drive progress in science and industry.

Contact

Address: 3281 E Guasti Rd
Ontario, CA 91761, United States
Phone: (601) 213-4426
Email: info@benchchem.com

[Contact our Ph.D. Support Team for a compatibility check](#)