

A Comparative Guide to the Mass Spectrometry Fragmentation Patterns of Fluorinated Piperidines

Author: BenchChem Technical Support Team. **Date:** May 2026

Compound of Interest

Compound Name: 3-(3,4,5-Trifluorophenyl)piperidine

Cat. No.: B12999148

[Get Quote](#)

Introduction: The Significance of Fluorinated Piperidines and the Role of Mass Spectrometry

The introduction of fluorine into organic molecules has become a cornerstone of modern drug discovery. The unique properties of fluorine, such as its high electronegativity, small size, and ability to form strong carbon-fluorine bonds, can profoundly influence a molecule's metabolic stability, lipophilicity, and binding affinity to biological targets.[1] The piperidine scaffold, a ubiquitous heterocyclic amine, is a privileged structure in medicinal chemistry, appearing in numerous approved drugs.[1] Consequently, the strategic incorporation of fluorine into the piperidine ring system offers a powerful approach to fine-tune the pharmacokinetic and pharmacodynamic properties of drug candidates.

Mass spectrometry is an indispensable analytical tool for the structural characterization of these novel fluorinated piperidines.[2] Understanding their fragmentation patterns under different ionization conditions is crucial for their unambiguous identification, impurity profiling, and metabolite identification studies. This guide provides an in-depth comparison of the mass spectrometric fragmentation behavior of fluorinated piperidines, offering insights into the

influence of fluorine substitution on fragmentation pathways. We will explore the key differences and similarities in the fragmentation of positional isomers and compounds with varying degrees of fluorination, supported by experimental data and mechanistic interpretations.

Fundamental Fragmentation Pathways of the Piperidine Ring

The fragmentation of the piperidine ring in a mass spectrometer is primarily dictated by the ionization method and the nature and position of its substituents.[3] Under typical Electron Ionization (EI), the fragmentation process is often initiated by the ionization of the basic nitrogen atom.[3] This leads to several characteristic fragmentation pathways:

- **α -Cleavage:** This is a dominant fragmentation pathway in EI-MS. It involves the cleavage of a carbon-carbon bond adjacent to the nitrogen atom, resulting in the formation of a resonance-stabilized iminium ion.[3] The largest substituent at the α -carbon is preferentially lost.
- **Ring Fission:** The piperidine ring can undergo cleavage to form various acyclic fragment ions.
- **Substituent-Driven Fragmentation:** The fragmentation pattern is heavily influenced by the nature of the substituents on the piperidine ring.

Electrospray Ionization (ESI), a softer ionization technique, typically generates protonated molecules, $[M+H]^+$. Tandem mass spectrometry (MS/MS) of these precursor ions reveals characteristic fragmentation patterns, often initiated by the protonated nitrogen. Common pathways include the neutral loss of small molecules.[2][4]

The Influence of Fluorine Substitution on Fragmentation Patterns

The introduction of one or more fluorine atoms onto the piperidine ring significantly alters its electron distribution and bond strengths, thereby influencing its fragmentation behavior. The high electronegativity of fluorine can induce bond cleavages and rearrangements that are less common in their non-fluorinated counterparts.

Comparison of Monofluorinated Piperidine Isomers (2-F, 3-F, and 4-F)

While comprehensive, direct comparative studies on the mass spectra of all fluorinated piperidine isomers are not readily available in the literature, we can predict their fragmentation patterns based on established principles and data from related compounds.

Electron Ionization (EI) Fragmentation:

Under EI conditions, the initial ionization will likely occur at the nitrogen atom. The subsequent fragmentation will be influenced by the position of the fluorine atom.

- **2-Fluoropiperidine:** The presence of a fluorine atom on the α -carbon is expected to influence the α -cleavage pathway. The strong electron-withdrawing nature of fluorine might disfavor the formation of a positive charge on the adjacent carbon. However, the loss of a hydrogen radical from the α -carbon to form an iminium ion is still a plausible pathway. A key fragmentation may involve the elimination of a neutral HF molecule.
- **3-Fluoropiperidine:** With the fluorine at the β -position, the initial α -cleavage is expected to be more prominent, similar to unsubstituted piperidine. The primary fragment would likely be the iminium ion formed by the loss of an ethyl radical. Subsequent fragmentation of the ring may be influenced by the fluorine substituent, potentially leading to fragments containing the C-F bond.
- **4-Fluoropiperidine:** In 4-fluoropiperidine, the fluorine atom is at the γ -position relative to the nitrogen. The initial α -cleavage should proceed as in the unsubstituted piperidine. The presence of the fluorine atom may direct subsequent ring fission pathways. The loss of HF through a rearrangement process is also a possibility.

The following table summarizes the predicted key fragment ions for monofluorinated piperidine isomers under EI-MS.

Isomer	Predicted Key Fragment Ions (m/z)	Plausible Neutral Losses
2-Fluoropiperidine	103 (M+•), 102 ([M-H] ⁺), 84 ([M-HF] ⁺), 70	H•, HF
3-Fluoropiperidine	103 (M+•), 84 ([M-CH ₂ CH ₂ F] ⁺), 70	C ₂ H ₄ F•
4-Fluoropiperidine	103 (M+•), 84 ([M-CH ₃ CHF] ⁺), 70	C ₂ H ₄ F•

Electrospray Ionization Tandem Mass Spectrometry (ESI-MS/MS) Fragmentation:

In ESI-MS/MS, the protonated molecule [M+H]⁺ is the precursor ion. The fragmentation will be driven by the protonated nitrogen.

- For all isomers, a characteristic loss of HF is anticipated. The stability of the resulting carbocation will likely influence the relative abundance of this fragment.
- Ring-opening and subsequent fragmentation will also occur, and the position of the fluorine atom will dictate the masses of the resulting fragment ions.

Comparison of Mono- vs. Di- and Polyfluorinated Piperidines

Increasing the degree of fluorination is expected to have a pronounced effect on the fragmentation patterns.

- **Increased Propensity for HF Loss:** With more fluorine atoms, the statistical probability of losing a molecule of HF increases. We can anticipate observing sequential losses of HF.
- **Altered Ring Cleavage:** The presence of multiple electron-withdrawing fluorine atoms will significantly alter the electron density within the piperidine ring, leading to different ring fission pathways compared to their mono-fluorinated or non-fluorinated analogs.
- **Charge Localization:** The fluorine atoms can influence the site of protonation in ESI, which in turn affects the subsequent fragmentation cascade.

Experimental Protocols

Gas Chromatography-Mass Spectrometry (GC-MS) Analysis

GC-MS is a suitable technique for the analysis of volatile and thermally stable fluorinated piperidines.

Methodology:

- Sample Preparation: Dissolve the fluorinated piperidine derivative in a suitable volatile solvent (e.g., methanol, dichloromethane) to a concentration of approximately 1 mg/mL.
- GC System:
 - Injector: Split/splitless injector, operated in splitless mode.
 - Column: A non-polar or mid-polar capillary column, such as a DB-5MS or HP-5MS (30 m x 0.25 mm i.d., 0.25 μ m film thickness).
 - Oven Temperature Program: Start at 50°C, hold for 2 minutes, then ramp to 250°C at 10°C/min, and hold for 5 minutes.
 - Carrier Gas: Helium at a constant flow rate of 1 mL/min.
- MS System:
 - Ionization: Electron Ionization (EI) at 70 eV.
 - Mass Analyzer: Quadrupole or Time-of-Flight (TOF).
 - Scan Range: m/z 40-400.

Liquid Chromatography-Tandem Mass Spectrometry (LC-MS/MS) Analysis

LC-MS/MS is ideal for the analysis of less volatile or thermally labile fluorinated piperidines, and for obtaining detailed structural information through fragmentation experiments.^[3]

Methodology:

- Sample Preparation: Dissolve the fluorinated piperidine derivative in a suitable solvent compatible with the mobile phase (e.g., methanol, acetonitrile) to a concentration of approximately 1 µg/mL.
- LC System:
 - Column: A C18 reversed-phase column (e.g., 100 mm x 2.1 mm i.d., 1.8 µm particle size).
 - Mobile Phase A: 0.1% formic acid in water.
 - Mobile Phase B: 0.1% formic acid in acetonitrile.
 - Gradient: Start with 5% B, hold for 1 minute, ramp to 95% B over 8 minutes, hold for 2 minutes, and then return to initial conditions.
 - Flow Rate: 0.3 mL/min.
- MS/MS System:
 - Ionization: Electrospray Ionization (ESI) in positive ion mode.
 - Mass Analyzer: Triple quadrupole or Quadrupole-Time-of-Flight (Q-TOF).
 - MS1 Scan: Full scan from m/z 100-500 to identify the protonated molecule [M+H]⁺.
 - MS2 Scan (Product Ion Scan): Select the [M+H]⁺ ion as the precursor and fragment it using collision-induced dissociation (CID) with nitrogen or argon as the collision gas. Optimize collision energy to obtain a rich fragmentation spectrum.

Visualization of Fragmentation Pathways

The following diagrams, generated using Graphviz, illustrate the proposed key fragmentation pathways for fluorinated piperidines.

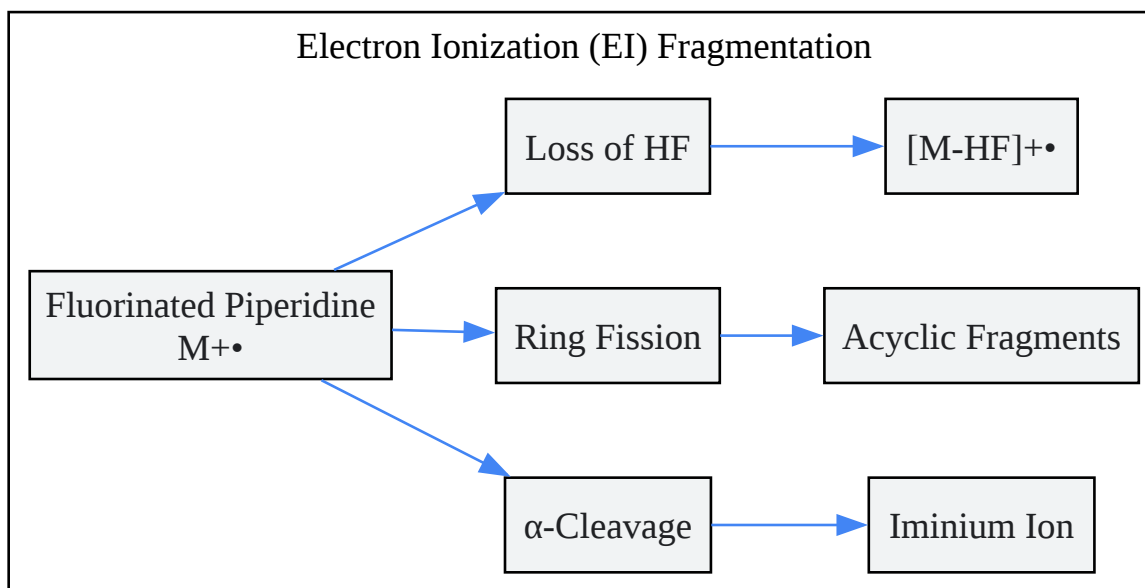

[Click to download full resolution via product page](#)

Caption: General EI fragmentation pathways of fluorinated piperidines.

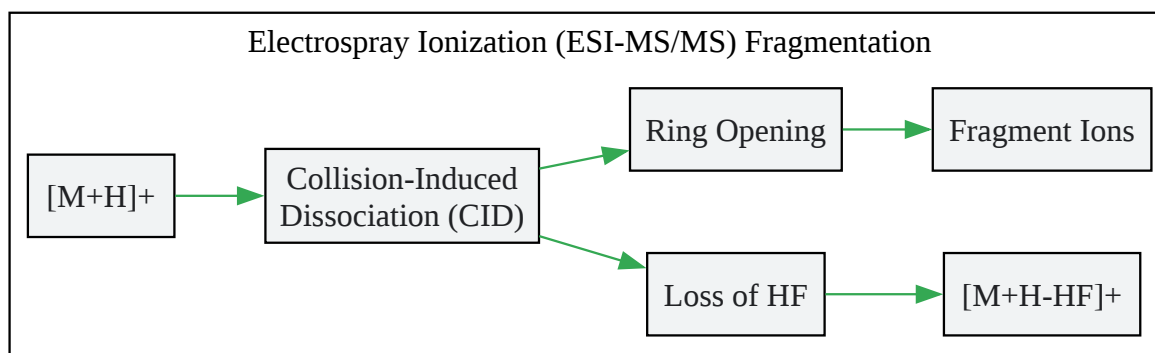

[Click to download full resolution via product page](#)

Caption: General ESI-MS/MS fragmentation pathways of fluorinated piperidines.

Conclusion and Future Perspectives

The fragmentation patterns of fluorinated piperidines in mass spectrometry are a complex interplay of the inherent reactivity of the piperidine ring and the profound electronic effects of

fluorine substitution. While general fragmentation pathways such as α -cleavage and ring fission are observed, the position and number of fluorine atoms introduce unique and diagnostic fragmentation channels, most notably the loss of neutral HF.

This guide provides a foundational understanding for researchers working on the characterization of these important molecules. However, the field would greatly benefit from more systematic and comparative studies, including the analysis of a wider range of fluorinated piperidine isomers and the use of high-resolution mass spectrometry to confirm elemental compositions of fragment ions. Furthermore, computational studies modeling the fragmentation energetics would provide deeper mechanistic insights and enhance our predictive capabilities. As the diversity of fluorinated piperidines in drug discovery continues to expand, a thorough understanding of their mass spectrometric behavior will remain a critical aspect of their analytical characterization.

References

- Le Roch, M., Renault, J., Argouarch, G., Roisnel, T., & Nicolas, C. (2024). Synthesis and Chemoinformatic Analysis of Fluorinated Piperidines as 3D Fragments for Fragment-Based Drug Discovery. *The Journal of Organic Chemistry*, 89(7), 4932–4946. [[Link](#)]
- PubChem. (n.d.). 4-Fluoropiperidine. National Center for Biotechnology Information. Retrieved from [[Link](#)]
- PubChem. (n.d.). 4,4-Difluoropiperidine. National Center for Biotechnology Information. Retrieved from [[Link](#)]
- de Souza, G. E. P., de Oliveira, D. N., & de Almeida, M. V. (2018). Mass spectrometry for characterization of homologous piperidine alkaloids and their activity as acetylcholinesterase inhibitors. *Rapid Communications in Mass Spectrometry*, 32(19), 1697–1706. [[Link](#)]
- NIST. (n.d.). Piperidine. In NIST Chemistry WebBook. National Institute of Standards and Technology. Retrieved from [[Link](#)]
- NIST. (n.d.). 2-Fluoropyridine. In NIST Chemistry WebBook. National Institute of Standards and Technology. Retrieved from [[Link](#)]

- Mondello, L. (2016). *Mass Spectra of Flavors and Fragrances of Natural and Synthetic Compounds* (3rd ed.). Wiley.
- Falk, F., & Jackson, G. (2020). The influence of chemical modifications on the fragmentation behavior of fentanyl and fentanyl-related compounds in electrospray ionization tandem mass spectrometry. *Journal of Mass Spectrometry*, 55(6), e4485. [[Link](#)]
- Westphal, F., & Rösner, P. (2009). Differentiation of regioisomeric ring-substituted fluorophenethylamines with product ion spectrometry. *Forensic Science International*, 192(1-3), 83–90. [[Link](#)]
- Zhang, J., Oxley, J., Smith, J., Bedford, C., & Chapman, R. (2000). Mass spectral fragmentation pathways in cyclic difluoramino and nitro compounds. *Journal of Mass Spectrometry*, 35(7), 841–852. [[Link](#)]
- Mohler, D. L., Dombrowski, R. D., & Glish, G. L. (1993). Fragmentation of fluorinated benzenes in a quadrupole ion trap mass spectrometer. *Journal of the American Society for Mass Spectrometry*, 4(8), 643–649. [[Link](#)]
- G. A. Eiceman, Z. Karpas, H. H. Hill, Jr. (2009). *Ion Mobility Spectrometry, Third Edition*. CRC Press.
- Schymanski, E. L., Jeon, J., Gulde, R., Fenner, K., & Hollender, J. (2014). Identifying small molecules by high resolution mass spectrometry: the suspect screening workflow. *Environmental Science & Technology*, 48(4), 2097–2098. [[Link](#)]
- Murphy, R. C. (2020). *Mass Spectrometry of Lipids*. In *Biochemistry of Lipids, Lipoproteins and Membranes* (6th ed., pp. 55-82). Elsevier.
- Sparkman, O. D., Penton, Z., & Kitson, F. G. (2011). *Gas Chromatography and Mass Spectrometry: A Practical Guide*. Academic Press.
- Pivatto, M., Crotti, A. E. M., Lopes, N. P., Castro-Gamboa, I., de Rezende, A., Viegas, C., Jr., Young, M. C. M., Furlan, M., & Bolzani, V. S. (2005). Electrospray ionization mass spectrometry screening of piperidine alkaloids from *Senna spectabilis* (Fabaceae) extracts: fast identification of new constituents and co-metabolites. *Journal of the Brazilian Chemical Society*, 16(6B), 1433-1440. [[Link](#)]

- The formation of all-cis-(multi)fluorinated piperidines by a dearomatization-hydrogenation process. (2019). *Nature Communications*, 10(1), 337. [[Link](#)]
- Exploring fluorine-substituted piperidines as potential therapeutics for diabetes mellitus and Alzheimer's diseases. (2024). *Journal of Biomolecular Structure & Dynamics*, 1-16. [[Link](#)]
- Mass spectrometry for characterization of homologous piperidine alkaloids and their activity as acetylcholinesterase inhibitors. (2018). *Rapid Communications in Mass Spectrometry*, 32(19), 1697-1706. [[Link](#)]
- Syn-3-Fluoro-4-aminopiperidine- a story from multiple orientations. (2019). *Scientific Update*. [[Link](#)]
- Study on the Mass Spectrometry Fragmentation Patterns for Rapid Screening and Structure Identification of Ketamine Analogues in Illicit Powders. (2023). *Molecules*, 28(18), 6549. [[Link](#)]
- 3-Fluoropiperidines and N-methyl-3-fluoropiperidinium salts: the persistence of axial fluorine. (2005). *Journal of the American Chemical Society*, 127(8), 2615-2625. [[Link](#)]
- Electron impact mass spectral fragmentation patterns of 2a,4-disubstituted 5-benzoyl-2-chloro-2a,3,4,5-tetrahydroazeto[1,2-a][1][5]benzodiazepin-1(2H)-ones. (1997). *Journal of Mass Spectrometry*, 32(11), 1195-1202. [[Link](#)]
- Underlying Mechanisms of Chromatographic H/D, H/F, cis/trans and Isomerism Effects in GC-MS. (2025). *International Journal of Molecular Sciences*, 26(2), 437. [[Link](#)]
- GC-MS and GC-IR Analysis of Disubstituted Piperazine Analogues of Benzylpiperazine and Trifluoromethylphenylpiperazine. (2025). *Journal of Analytical Toxicology*, 49(6), 567-576. [[Link](#)]
- The differentiation of positional isomers utilizing GC-IRD. (2018). *Journal of Forensic Sciences*, 63(5), 1474-1480. [[Link](#)]
- Mass spectra of fluorocarbons. (1952). *Journal of Research of the National Bureau of Standards*, 49(4), 235-240. [[Link](#)]

Need Custom Synthesis?

BenchChem offers custom synthesis for rare earth carbides and specific isotopic labeling.

Email: info@benchchem.com or [Request Quote Online](#).

Sources

- 1. The formation of all-cis-(multi)fluorinated piperidines by a dearomatization-hydrogenation process - PMC [[pmc.ncbi.nlm.nih.gov](https://pubmed.ncbi.nlm.nih.gov/pmc/)]
- 2. Mass spectrometry for characterization of homologous piperidine alkaloids and their activity as acetylcholinesterase inhibitors - PubMed [pubmed.ncbi.nlm.nih.gov]
- 3. pdf.benchchem.com [pdf.benchchem.com]
- 4. scielo.br [scielo.br]
- 5. mdpi.com [mdpi.com]
- To cite this document: BenchChem. [A Comparative Guide to the Mass Spectrometry Fragmentation Patterns of Fluorinated Piperidines]. BenchChem, [2026]. [Online PDF]. Available at: [<https://www.benchchem.com/product/b12999148/docs#a-comparative-guide-to-the-mass-spectrometry-fragmentation-patterns-of-fluorinated-piperidines>]

Disclaimer & Data Validity:

The information provided in this document is for Research Use Only (RUO) and is strictly not intended for diagnostic or therapeutic procedures. While BenchChem strives to provide accurate protocols, we make no warranties, express or implied, regarding the fitness of this product for every specific experimental setup.

Technical Support: The protocols provided are for reference purposes. Unsure if this reagent suits your experiment?

Need Industrial/Bulk Grade? [Request Custom Synthesis Quote](#)

BenchChem

Our mission is to be the trusted global source of essential and advanced chemicals, empowering scientists and researchers to drive progress in science and industry.

Contact

Address: 3281 E Guasti Rd

Ontario, CA 91761, United States

Phone: (601) 213-4426

Email: info@benchchem.com

[Contact our Ph.D. Support Team for a compatibility check](#)