

Technical Guide: dl-Alanyl-l-leucine (Stereochemical Probes & Stability)

Author: BenchChem Technical Support Team. **Date:** May 2026

Compound of Interest

Compound Name: *dl-Alanyl-l-leucine*

Cat. No.: *B12998351*

[Get Quote](#)

Executive Summary

dl-Alanyl-l-leucine (PubChem CID 259583) represents a specific diastereomeric mixture utilized primarily as a stable isotopic standard, a transport probe, and a substrate for investigating stereospecific enzymatic hydrolysis.[1] Unlike pure L-Alanyl-L-leucine, which is rapidly degraded by cytosolic peptidases, the inclusion of the racemic N-terminal alanine (DL-Ala) creates a mixture containing D-Alanyl-L-leucine and L-Alanyl-L-leucine.[1]

This guide details the physicochemical properties, synthesis, and analytical separation of these diastereomers. It specifically addresses the utility of the D-isomer component as a metabolically stable probe for PEPT1/PEPT2 transporter kinetics, distinguishing transport activity from intracellular hydrolysis.[1]

Physicochemical Profile

The following data characterizes the **dl-Alanyl-l-leucine** mixture. Note that while the molecular weight is identical for both diastereomers, their biological fate and chromatographic retention times differ significantly.[1]

Property	Data	Notes
IUPAC Name	(2RS)-2-amino-N-[(1S)-1-carboxy-3-methylbutyl]propanamide	Mixture of (R,S) and (S,S) isomers
Molecular Formula	C ₉ H ₁₈ N ₂ O ₃	
Molecular Weight	202.25 g/mol	
Solubility (Water)	~80 mg/mL (20°C)	High solubility facilitates aqueous buffer preparation
pKa Values	-COOH: 3.15; -NH ₃ ⁺ : 8.25	Zwitterionic at physiological pH (7.[2]4)
LogP	-1.52 (Estimated)	Hydrophilic; requires transporter for cell entry
Stability	Solid: >2 years at -20°C	Solution: Hydrolysis-prone (L-L form) at RT

Stereochemical & Enzymatic Dynamics[3]

The critical value of this compound lies in the differential processing of its two constituents.[1]

This self-validating system allows researchers to decouple uptake from metabolism.[1]

Mechanism of Action

- L-Alanyl-L-leucine (S,S): Recognized by peptide transporters (PEPT1/2) and rapidly hydrolyzed by intracellular peptidases (e.g., aminopeptidase N) into free L-Alanine and L-Leucine.[1]
- D-Alanyl-L-leucine (R,S): Recognized by peptide transporters with similar affinity but resistant to hydrolysis.[1] It accumulates intracellularly, allowing for precise quantification of transport capacity without the confounding factor of metabolic degradation.[1]

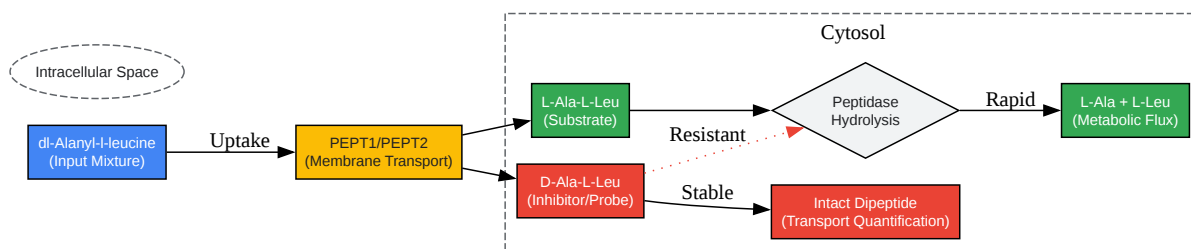

[Click to download full resolution via product page](#)

Figure 1: Differential metabolic fate of the **dl-Alanyl-l-leucine** diastereomers.[1] The D-Ala-containing isomer resists hydrolysis, serving as a stable transport probe.

Synthesis Protocol: Mixed Anhydride Coupling

To synthesize **dl-Alanyl-l-leucine**, a standard solution-phase peptide coupling strategy is employed.[1] This protocol uses N-protection with Boc (tert-butyloxycarbonyl) and C-terminal protection with a methyl ester to ensure regioselectivity.[1]

Reagents Required[1][4][5][6][7][8]

- Reagents: Boc-DL-Alanine, L-Leucine Methyl Ester HCl, Isobutyl Chloroformate (IBCF), N-Methylmorpholine (NMM), Trifluoroacetic acid (TFA), NaOH.[1]
- Solvents: Tetrahydrofuran (THF), Dichloromethane (DCM), Ethyl Acetate.[1]

Step-by-Step Methodology

- Activation (Mixed Anhydride Formation):
 - Dissolve Boc-DL-Alanine (10 mmol) in anhydrous THF (50 mL) under nitrogen.
 - Cool to -15°C. Add NMM (10 mmol) followed dropwise by IBCF (10 mmol).

- Checkpoint: Formation of a white precipitate (NMM·HCl) indicates successful activation.^[1]
Stir for 15 min.
- Coupling:
 - Dissolve L-Leucine Methyl Ester HCl (10 mmol) and NMM (10 mmol) in DCM (20 mL).
 - Add this solution to the activated anhydride mixture at -15°C.
 - Allow to warm to room temperature (RT) and stir for 4 hours.
 - Validation: Monitor by TLC (System: CHCl₃/MeOH 9:1).^[1] The starting material spot should disappear.^[1]
- Workup & Deprotection:
 - Evaporate solvent.^[1] Dissolve residue in Ethyl Acetate and wash with 5% KHSO₄, 5% NaHCO₃, and brine.^[1] Dry over MgSO₄.^[1]
 - N-Terminal Deprotection: Treat the intermediate (Boc-DL-Ala-L-Leu-OMe) with 50% TFA in DCM for 1 hour.^[1] Evaporate TFA.
 - C-Terminal Deprotection: Dissolve in MeOH/Water (1:1), add 1M NaOH (2 eq), and stir for 2 hours. Neutralize with 1M HCl to pH 6.0.
- Purification:
 - Lyophilize the neutralized solution.^[1]
 - Desalt using a C18 Solid Phase Extraction (SPE) cartridge or preparative HPLC if pure diastereomer separation is required (see Section 5).^[1]

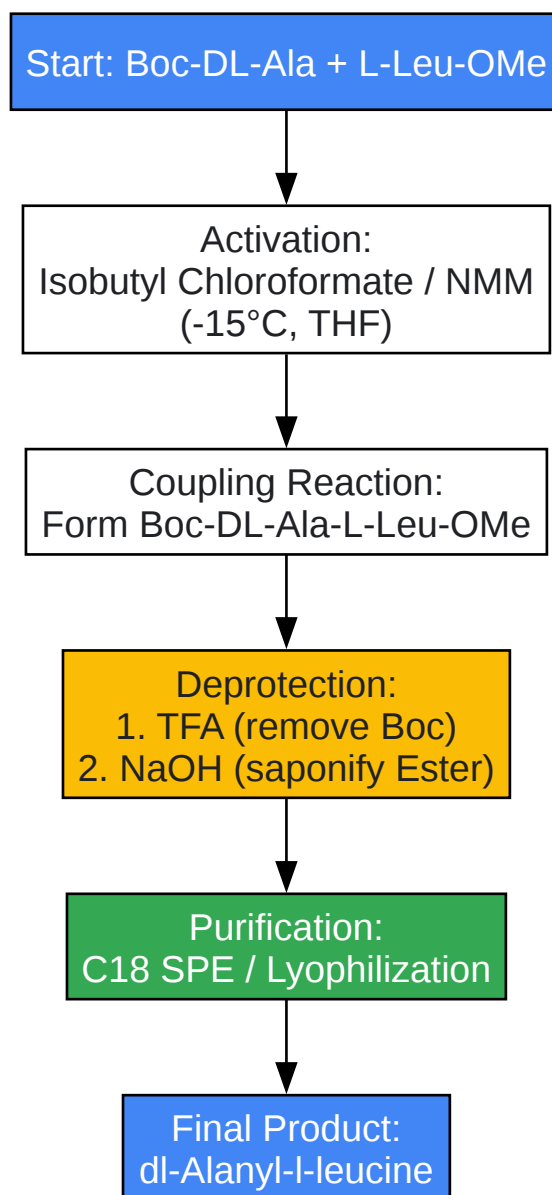

[Click to download full resolution via product page](#)

Figure 2: Chemical synthesis workflow for **dl-Alanyl-L-leucine** via mixed anhydride coupling.

Analytical Characterization & Separation

Separating the D-Ala-L-Leu and L-Ala-L-Leu diastereomers is critical for quality control and metabolic studies.[1] Standard C18 columns often fail to resolve these isomers efficiently without chiral additives.[1]

HPLC Method (Chiral Separation)

This protocol uses a ligand-exchange mechanism or a macrocyclic antibiotic phase to separate diastereomers.[1]

- Column: Chirobiotic T (Teicoplanin) or equivalent chiral column (4.6 x 250 mm, 5 μ m).[1]
- Mobile Phase: 20 mM Ammonium Acetate (pH 4.5) : Methanol (40:60 v/v).
- Flow Rate: 0.8 mL/min.[1]
- Detection: UV at 210 nm or MS (ESI+).[1]
- Expected Retention:
 - L-Ala-L-Leu: ~6.5 min[1]
 - D-Ala-L-Leu: ~8.2 min (D-isomer typically elutes later on Teicoplanin phases due to stronger interaction).[1]

Mass Spectrometry (LC-MS/MS)

For biological matrices (plasma/cell lysate), use MRM (Multiple Reaction Monitoring).[1]

- Ionization: ESI Positive Mode.
- Precursor Ion:m/z 203.1 [M+H]⁺[1]
- Product Ions:
 - m/z 86.1 (Leucine immonium ion) - Quantifier.[1]
 - m/z 44.0 (Alanine fragment) - Qualifier.[1]
- Collision Energy: 15-20 eV.[1]

References

- PubChem. (n.d.).[1][3][4] DL-Alanyl-DL-leucine (CID 259583).[1] National Library of Medicine.[1][4] Retrieved February 6, 2026, from [[Link](#)]

- Brandsch, M., et al. (2008).[1] Transport of D-amino acid containing dipeptides by the H+/peptide transporters PEPT1 and PEPT2.[1] Journal of Pharmacology and Experimental Therapeutics.[1] [\[Link\]](#)
- Smith, D. E., & Clémenton, B. (2004).[1] Peptide transporters: Structure, function, and regulation.[1] American Journal of Physiology-Renal Physiology.[1] [\[Link\]](#)

Need Custom Synthesis?

BenchChem offers custom synthesis for rare earth carbides and specific isotopic labeling.

Email: info@benchchem.com or [Request Quote Online](#).

Sources

- 1. DL-Alanyl-DL-leucine | C₉H₁₈N₂O₃ | CID 259583 - PubChem [pubchem.ncbi.nlm.nih.gov]
- 2. dl-Alanine (CAS 302-72-7) - Chemical & Physical Properties by Cheméo [cheméo.com]
- 3. L-Leucine | C₆H₁₃NO₂ | CID 6106 - PubChem [pubchem.ncbi.nlm.nih.gov]
- 4. D-Ala-Leu | C₉H₁₈N₂O₃ | CID 6992388 - PubChem [pubchem.ncbi.nlm.nih.gov]
- To cite this document: BenchChem. [Technical Guide: dl-Alanyl-l-leucine (Stereochemical Probes & Stability)]. BenchChem, [2026]. [Online PDF]. Available at: [<https://www.benchchem.com/product/b12998351/docs#technical-guide-dl-alanyl-l-leucine-stereochemical-probes-stability>]

Disclaimer & Data Validity:

The information provided in this document is for Research Use Only (RUO) and is strictly not intended for diagnostic or therapeutic procedures. While BenchChem strives to provide accurate protocols, we make no warranties, express or implied, regarding the fitness of this product for every specific experimental setup.

Technical Support: The protocols provided are for reference purposes. Unsure if this reagent suits your experiment?

Need Industrial/Bulk Grade? [Request Custom Synthesis Quote](#)

BenchChem

Our mission is to be the trusted global source of essential and advanced chemicals, empowering scientists and researchers to drive progress in science and industry.

Contact

Address: 3281 E Guasti Rd

Ontario, CA 91761, United States

Phone: (601) 213-4426

Email: info@benchchem.com

[Contact our Ph.D. Support Team for a compatibility check](#)