

Topic: Catalyst for 2-(3,5-Dimethylphenoxy)benzaldehyde Synthesis

Author: BenchChem Technical Support Team. **Date:** May 2026

Compound of Interest

Compound Name:	2-(3,5-Dimethylphenoxy)benzaldehyde
CAS No.:	320423-51-6
Cat. No.:	B1299730

[Get Quote](#)

Application Note: A Ligand-Accelerated, Copper-Catalyzed Ullmann Condensation Protocol for the Synthesis of 2-(3,5-Dimethylphenoxy)benzaldehyde

This guide provides a comprehensive, field-proven protocol for the synthesis of **2-(3,5-Dimethylphenoxy)benzaldehyde**, a valuable diaryl ether intermediate. We move beyond a simple recitation of steps to explain the underlying chemical principles, empowering researchers to not only replicate the synthesis but also to intelligently adapt it. The core of this methodology is a modern iteration of the Ullmann condensation, leveraging a copper(I) catalyst system enhanced by a chelating ligand to achieve efficient C-O bond formation under significantly milder conditions than traditional methods.

Foundational Principles: The Modern Ullmann Condensation

The synthesis of diaryl ethers is a fundamental transformation in organic chemistry, with the resulting structural motif present in numerous natural products and pharmaceuticals.[1][2] The Ullmann condensation, first reported over a century ago, is a classic copper-promoted C-O cross-coupling reaction between an aryl halide and a phenol.[3][4]

Historically, this reaction was plagued by harsh requirements, including high temperatures (often >200 °C) and stoichiometric amounts of copper metal, which limited its scope and functional group tolerance.[1][5] The modern paradigm shift involves the use of soluble copper(I) salts (e.g., CuI) in catalytic amounts, co-catalyzed by a chelating ligand. This innovation dramatically improves reaction efficiency and broadens the substrate scope.[5]

The Role of the Catalyst System:

- **Copper(I) Source:** Copper(I) iodide (CuI) is a commonly used and effective precursor for the active Cu(I) catalyst. It is believed that the Cu(I) species is the true catalyst, capable of entering the catalytic cycle.[6][7]
- **Ligand:** The ligand is arguably the most critical component of the modern Ullmann reaction. Simple, bidentate ligands such as N,N'-dimethylethylenediamine (DMEDA) or 1,10-phenanthroline chelate to the copper center. This chelation stabilizes the copper catalyst, increases its solubility, and, most importantly, facilitates the key steps of oxidative addition and reductive elimination, thereby lowering the activation energy of the reaction.[5][8] This allows the reaction to proceed at much lower temperatures (e.g., 100-130 °C).
- **Base:** A base is required to deprotonate the phenol (3,5-dimethylphenol), forming the corresponding phenoxide. This phenoxide is the active nucleophile that coordinates to the copper center. While various bases can be used, potassium carbonate (K₂CO₃) and cesium carbonate (Cs₂CO₃) are particularly effective.[1] Cs₂CO₃ is often favored for its higher solubility in organic solvents, though K₂CO₃ provides an excellent, cost-effective alternative.

Catalytic Cycle Mechanism

The precise mechanism of the ligand-assisted Ullmann condensation is a subject of extensive study, but a widely accepted catalytic cycle is illustrated below. The cycle is initiated by the formation of a copper(I) phenoxide complex. This complex then undergoes oxidative addition with the aryl halide (2-chlorobenzaldehyde) to form a transient, high-energy copper(III)

intermediate. The final, crucial step is the reductive elimination of this intermediate, which forms the desired C-O bond of the diaryl ether product and regenerates the active copper(I) catalyst.

[6][9][10]

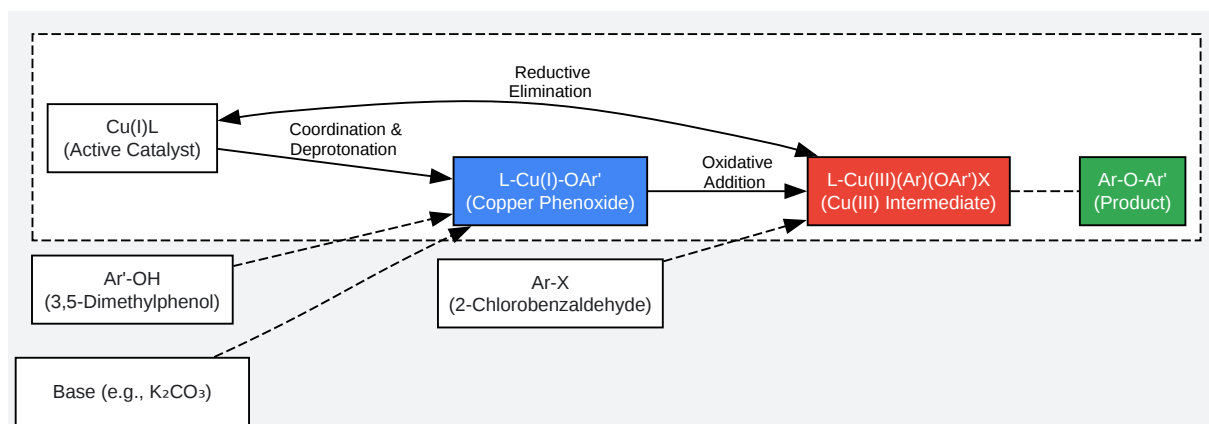

[Click to download full resolution via product page](#)

Caption: Proposed catalytic cycle for the ligand-assisted Ullmann C-O coupling reaction.

Comparative Catalyst System Data

The choice of catalyst, ligand, base, and solvent significantly impacts reaction efficiency. Below is a summary of common systems used for Ullmann diaryl ether synthesis, providing a basis for experimental design and optimization.

Catalyst (mol%)	Ligand (mol%)	Base (equiv)	Solvent	Temp (°C)	Typical Yield	Reference
CuI (5-10)	None (Traditional)	K ₂ CO ₃ (2.0)	DMF, Pyridine	150-220	Variable, often low	[1][3]
CuI (5)	1,10-Phenanthroline (10)	Cs ₂ CO ₃ (2.0)	Toluene	110	Good to Excellent	[1][5]
CuI (10)	DMEDA (20)	K ₂ CO ₃ (2.0)	Dioxane	100-110	Good to Excellent	[5]
CuI (15)	1,3-Diphenyl-1,3-propanedione (15)	KF/Al ₂ O ₃ (5.0)	Toluene	100-110	Good	[11]
CuCl (10)	Dimethylglycine (20)	Cs ₂ CO ₃ (2.0)	DMF	130	Moderate to Good	[2]

DMEDA = N,N'-dimethylethylenediamine; DMF = Dimethylformamide

Based on a balance of efficiency, cost, and availability, the CuI/DMEDA/K₂CO₃ system in a suitable solvent like dioxane or toluene presents a robust and reliable choice for the synthesis of **2-(3,5-Dimethylphenoxy)benzaldehyde**.

Detailed Experimental Protocol

This protocol details the synthesis of **2-(3,5-Dimethylphenoxy)benzaldehyde** from 2-chlorobenzaldehyde and 3,5-dimethylphenol.

Materials & Reagents:

- 2-Chlorobenzaldehyde (1.0 equiv)[12][13]
- 3,5-Dimethylphenol (1.2 equiv)[14][15]

- Copper(I) Iodide (CuI) (0.1 equiv)
- N,N'-Dimethylethylenediamine (DMEDA) (0.2 equiv)
- Potassium Carbonate (K₂CO₃), anhydrous, finely powdered (2.0 equiv)
- Anhydrous Toluene or Dioxane
- Ethyl Acetate (for extraction)
- Brine (saturated NaCl solution)
- Anhydrous Magnesium Sulfate (MgSO₄)
- Silica Gel (for chromatography)

Equipment:

- Schlenk flask or oven-dried, two-neck round-bottom flask
- Reflux condenser
- Magnetic stirrer with heating mantle
- Inert atmosphere setup (Argon or Nitrogen)
- Standard laboratory glassware for work-up and purification

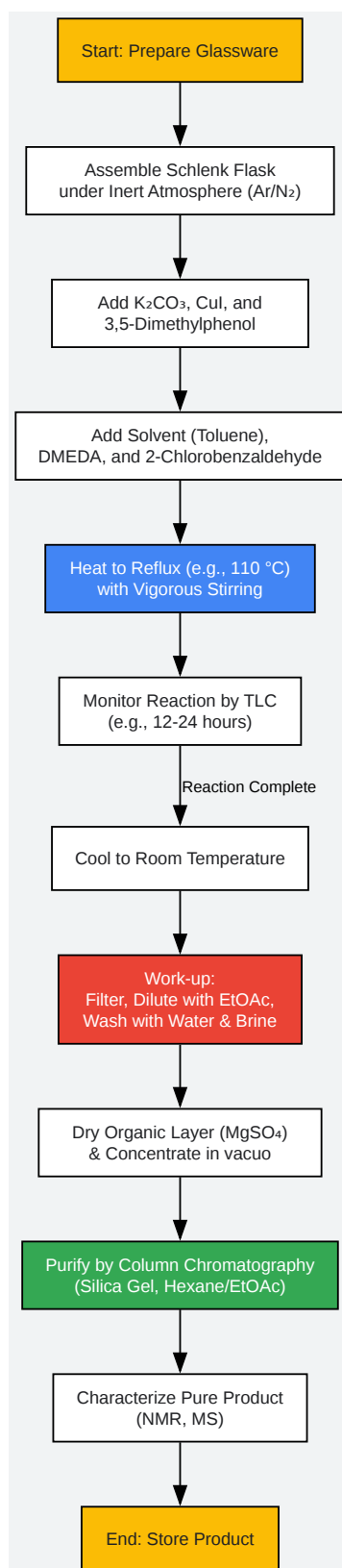

[Click to download full resolution via product page](#)

Caption: Step-by-step experimental workflow for the synthesis.

Step-by-Step Procedure:

- **Reaction Setup:** To an oven-dried Schlenk flask equipped with a magnetic stir bar, add 3,5-dimethylphenol (1.2 equiv), finely powdered anhydrous potassium carbonate (2.0 equiv), and copper(I) iodide (0.1 equiv).
- **Inert Atmosphere:** Seal the flask, and evacuate and backfill with an inert gas (Argon or Nitrogen) three times. This is crucial as oxygen can interfere with the catalytic cycle.
- **Reagent Addition:** Under a positive pressure of inert gas, add anhydrous toluene (or dioxane) to create a slurry of approximately 0.5 M concentration with respect to the limiting reagent. Add N,N'-dimethylethylenediamine (DMEDA, 0.2 equiv) via syringe, followed by 2-chlorobenzaldehyde (1.0 equiv).
- **Reaction Conditions:** Equip the flask with a reflux condenser (also under inert gas). Lower the flask into a heating mantle and heat the mixture to reflux (approx. 110 °C for toluene) with vigorous stirring.
- **Monitoring:** The reaction progress should be monitored by Thin Layer Chromatography (TLC) or LC-MS. The reaction is typically complete within 12-24 hours.
- **Work-up:** Once the reaction is complete, cool the mixture to room temperature. Dilute the mixture with ethyl acetate and filter through a pad of celite to remove insoluble inorganic salts.
- **Extraction:** Transfer the filtrate to a separatory funnel and wash sequentially with water (2x) and brine (1x). The aqueous washes help remove any remaining base and the DMEDA ligand.
- **Drying and Concentration:** Dry the organic layer over anhydrous magnesium sulfate (MgSO₄), filter, and concentrate the solvent under reduced pressure using a rotary evaporator to yield the crude product.
- **Purification:** The crude residue should be purified by flash column chromatography on silica gel using a hexane/ethyl acetate gradient to afford **2-(3,5-Dimethylphenoxy)benzaldehyde** as a pure solid or oil.[16]

Safety and Handling

- Aryl Halides & Phenols: 2-Chlorobenzaldehyde and 3,5-dimethylphenol are irritants. Handle with appropriate personal protective equipment (PPE), including gloves and safety glasses, in a well-ventilated fume hood.
- Copper Salts: Copper(I) iodide is harmful if swallowed and can cause irritation.^[10] Avoid inhalation of dust.
- Solvents: Toluene and dioxane are flammable and have associated health risks. Handle only in a fume hood away from ignition sources.
- Inert Atmosphere: Reactions should be conducted under an inert atmosphere to ensure catalyst efficacy and safety.

References

- Wikipedia. Ullmann condensation. [\[Link\]](#)
- Wikipedia. Ullmann reaction. [\[Link\]](#)
- Marcoux, J.-F., Doye, S., & Buchwald, S. L. (2000). A General Copper-Catalyzed Synthesis of Diaryl Ethers. *Journal of the American Chemical Society*, 122(18), 4605–4614. [\[Link\]](#)
- Slideshare. Ullmann reaction. [\[Link\]](#)
- Li, P., et al. (2019). Copper-catalyzed synthesis of phenol and diaryl ether derivatives via hydroxylation of diaryliodoniums. *RSC Advances*. [\[Link\]](#)
- SynArchive. Ullmann Condensation. [\[Link\]](#)
- Evano, G., et al. (2013). RECENT SYNTHETIC DEVELOPMENTS AND APPLICATIONS OF THE ULLMANN REACTION. *PMC - NIH*. [\[Link\]](#)
- Shen, H.-C., et al. (2022). Ligand-Enabled Copper-Catalyzed Ullmann-Type S–C Bond Formation to Access Sulfilimines. *Organic Letters*. [\[Link\]](#)

- RSC Publishing. Copper-catalyzed synthesis of phenol and diaryl ether derivatives via hydroxylation of diaryliodoniums. [[Link](#)]
- Hosseinzadeh, R., et al. (2008). Synthesis of Diaryl Ethers Through the Copper-Catalyzed Arylation of Phenols with Aryl Iodides Using KF/Al₂O₃. Taylor & Francis Online. [[Link](#)]
- Mohamed Shams, Y., & Al Malak, S. (2024). Synthesis of Diaryl Ethers via C-O Cross-Coupling of Phenols with Aryl Iodides in the Presence of Copper Catalyst. Journal of Synthetic Chemistry. [[Link](#)]
- Bacon, R. G. R., & Rennison, S. C. (1969). Mechanism of the Ullmann condensation reaction. Part III. Role of the copper catalyst. Journal of the Chemical Society, Perkin Transactions 2. [[Link](#)]
- van der Vight, L. P., et al. (2015). The Mechanism of the Modified Ullmann Reaction. ResearchGate. [[Link](#)]
- Inam, M., et al. (2024). Exploring the Chemistry, Reactions, Applications, and Biomedical Potentials of 2-Nitrobenzaldehyde and 2-Chlorobenzaldehyde. Name of the Journal. [[Link](#)]
- ResearchGate. Commonly used ligands applied for Cu-catalyzed Ullmann reactions. [[Link](#)]
- El-Sayed, N. F., et al. (2022). Heterocyclic compounds derived from cyclohexane-1,4-dione: synthesis of tetrahydro-4H-chromene and tetrahydrobenzo[d]thiazole derivatives as target SARS-CoV-2 main protease (Mpro) and potential anti-Covid-19. PMC - NIH. [[Link](#)]
- FooDB. Showing Compound 3,5-Dimethylphenol (FDB007241). [[Link](#)]
- Google Patents.
- PrepChem.com. Preparation of 2-chlorobenzaldehyde. [[Link](#)]
- PrepChem.com. Preparation of 3,5-dimethylphenol. [[Link](#)]
- Google Patents.
- The Good Scents Company. 3,5-xilenol. [[Link](#)]

- Chemical Science. Palladium-catalyzed intermolecular [4 + 1] annulation of N-phenoxyacetamides with aldehydes. [[Link](#)]
- Green Chemistry - RSC Publishing. Three-component synthesis of 2-amino-4H-chromene derivatives. [[Link](#)]
- Organic Chemistry Portal. Ullmann Reaction. [[Link](#)]

Need Custom Synthesis?

BenchChem offers custom synthesis for rare earth carbides and specific isotopic labeling.

Email: info@benchchem.com or [Request Quote Online](#).

Sources

1. pubs.acs.org [pubs.acs.org]
2. pdfs.semanticscholar.org [pdfs.semanticscholar.org]
3. Ullmann condensation - Wikipedia [en.wikipedia.org]
4. synarchive.com [synarchive.com]
5. RECENT SYNTHETIC DEVELOPMENTS AND APPLICATIONS OF THE ULLMANN REACTION. A REVIEW - PMC [[pmc.ncbi.nlm.nih.gov](https://pubmed.ncbi.nlm.nih.gov)]
6. researchgate.net [researchgate.net]
7. researchgate.net [researchgate.net]
8. Diamine Ligands for Ullmann-Type Cross-Coupling at Room Temperature | TCI AMERICA [tcichemicals.com]
9. pubs.acs.org [pubs.acs.org]
10. pdf.benchchem.com [pdf.benchchem.com]
11. tandfonline.com [tandfonline.com]
12. ojs.wiserpub.com [ojs.wiserpub.com]
13. prepchem.com [prepchem.com]
14. Showing Compound 3,5-Dimethylphenol (FDB007241) - FooDB [foodb.ca]
15. prepchem.com [prepchem.com]

- [16. 320423-51-6 Cas No. | 2-\(3,5-Dimethylphenoxy\)benzaldehyde | Apollo](#)
[\[store.apolloscientific.co.uk\]](#)
- To cite this document: BenchChem. [Topic: Catalyst for 2-(3,5-Dimethylphenoxy)benzaldehyde Synthesis]. BenchChem, [2026]. [Online PDF]. Available at: [\[https://www.benchchem.com/product/b1299730/docs#topic-catalyst-for-2-3-5-dimethylphenoxy-benzaldehyde-synthesis\]](https://www.benchchem.com/product/b1299730/docs#topic-catalyst-for-2-3-5-dimethylphenoxy-benzaldehyde-synthesis)

Disclaimer & Data Validity:

The information provided in this document is for Research Use Only (RUO) and is strictly not intended for diagnostic or therapeutic procedures. While BenchChem strives to provide accurate protocols, we make no warranties, express or implied, regarding the fitness of this product for every specific experimental setup.

Technical Support: The protocols provided are for reference purposes. Unsure if this reagent suits your experiment?

Need Industrial/Bulk Grade? [Request Custom Synthesis Quote](#)

BenchChem

Our mission is to be the trusted global source of essential and advanced chemicals, empowering scientists and researchers to drive progress in science and industry.

Contact

Address: 3281 E Guasti Rd
Ontario, CA 91761, United States
Phone: (601) 213-4426
Email: info@benchchem.com

[Contact our Ph.D. Support Team for a compatibility check](#)