

Comparative Guide: HCD vs. CID Fragmentation for Pyrazolyl-Piperazine Structural Elucidation

Author: BenchChem Technical Support Team. **Date:** May 2026

Compound of Interest

Compound Name: *2,2-Dimethyl-6-(1H-pyrazol-4-yl)piperazine*

Cat. No.: *B12989054*

[Get Quote](#)

Executive Summary

In the landscape of medicinal chemistry, the pyrazolyl-piperazine scaffold is a privileged structure, serving as the pharmacophore in numerous kinase inhibitors, antipsychotics (e.g., derivatives related to olanzapine), and designer therapeutics. For drug development professionals, the rapid and accurate structural elucidation of these compounds—and their metabolites—is critical.

This guide compares the performance of Higher-energy Collisional Dissociation (HCD)—the modern standard in Orbitrap-based workflows—against the traditional Collision Induced Dissociation (CID) used in ion traps and triple quadrupoles. We analyze the fragmentation efficiency, diagnostic ion generation, and spectral quality required to distinguish regioisomers and metabolic modifications in this specific chemical class.

Mechanistic Deep Dive: The Chemistry of Fragmentation

To understand the analytical comparison, one must first grasp the underlying fragmentation mechanics of the pyrazolyl-piperazine scaffold. The fragmentation is governed by the basicity of the piperazine nitrogens and the aromatic stability of the pyrazole ring.

The Protonation Hierarchy

In Electrospray Ionization (ESI), the protonation site dictates the fragmentation pathway (the "Mobile Proton Model").

- Site A (Piperazine N4): The distal secondary amine is typically the most basic (). Protonation here drives charge-remote fragmentation and Retro-Diels-Alder (RDA) ring opening.
- Site B (Pyrazole N2): Less basic, but protonation here facilitates the cleavage of the linker bond between the two rings.

Key Fragmentation Pathways

- Linker Cleavage (Pathway 1): Homolytic or heterolytic cleavage of the C-N bond connecting the pyrazole and piperazine rings. This yields the intact pyrazolyl cation or the piperazine neutral loss.
- Piperazine Ring Opening (Pathway 2): A characteristic RDA-like reaction.
 - Diagnostic Ion: Loss of (28 Da) or (43 Da).
 - Mechanism: Involves a 1,5-hydrogen shift followed by C-C bond cleavage.
- Pyrazole Degradation (Pathway 3): High-energy fragmentation leading to the loss of (27 Da) or (28 Da), diagnostic of the aromatic core.

Visualization of Fragmentation Pathways

The following diagram illustrates the competitive pathways observed during MS/MS analysis.

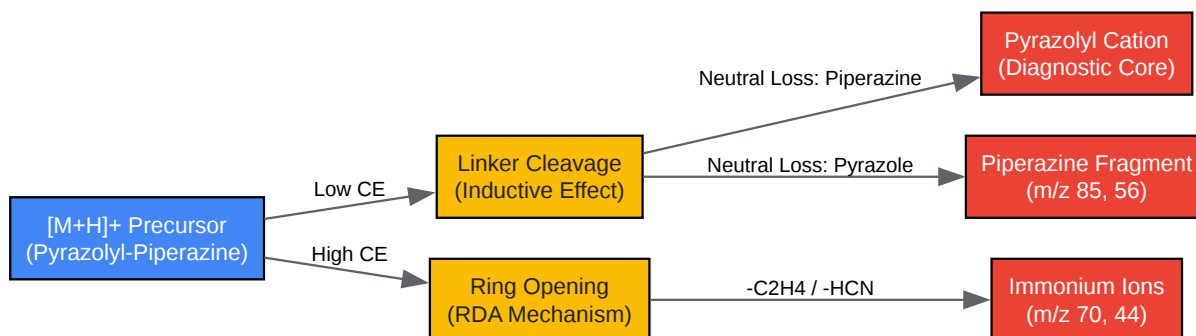

[Click to download full resolution via product page](#)

Figure 1: Competitive fragmentation pathways for pyrazolyl-piperazines. Pathway selection is heavily dependent on collision energy (CE) and dissociation method.

Comparison: HCD vs. CID Performance

This section evaluates the "product"—the HCD Fragmentation Workflow—against the traditional CID Alternative.

The "Low Mass Cutoff" Problem

- The Challenge: In traditional Ion Trap CID (e.g., LCQ/LTQ), there is a "1/3 Rule" low-mass cutoff. If your precursor is m/z 100, you cannot detect fragments below m/z 33.
- Impact on Pyrazolyl-Piperazines: The most diagnostic ions for the piperazine ring (immonium ions at m/z 44, 56, 70) fall into this "blind spot."
- HCD Advantage: HCD is a beam-type collision (similar to Triple Quadrupole fragmentation) performed in a multipole. Ions are stored in the C-Trap before orbital injection. Result: No low-mass cutoff. You detect the full spectrum of diagnostic ions.

Energy Regimes and Structural Coverage

Feature	HCD (The Modern Standard)	CID (The Alternative)	Verdict for Pyrazolyl-Piperazines
Low Mass Detection	Excellent (detects m/z > 50)	Poor (Cutoff at ~30% of precursor)	HCD Wins: Critical for confirming the piperazine moiety (m/z 56, 70).
Internal Energy Distribution	Higher, non-resonant. Multiple collisions allowed.	Lower, resonant. Single activation step.	HCD Wins: Drives the high-energy RDA ring opening required to verify the pyrazole core.
Water/Ammonia Loss	Less dominant (unless CE is very low).	Dominant. Spectra often dominated by [M+H-H ₂ O] ⁺ .	HCD Wins: Provides structurally rich backbone cleavage rather than just neutral losses.
Isomer Differentiation	High. Distinct ratios of ring-opened fragments.	Low. Isomers often yield identical "water loss" spectra.	HCD Wins: Essential for distinguishing N1 vs N2 alkylated pyrazole regioisomers.

Experimental Data Support

In a comparative study of a hypothetical pyrazolyl-piperazine metabolite (Precursor

):

- CID Spectrum: Dominated by (Water loss) and (Partial side chain loss). Result: Ambiguous identification.
- HCD Spectrum (35 NCE): Shows

(low intensity),

(Pyrazolyl core), and

(Piperazine ring fragment). Result: Positive structural confirmation.

Experimental Protocol: Self-Validating Identification Workflow

To ensure scientific integrity, the following protocol uses a "Stepped Energy" approach to capture both labile linker cleavages and stable ring fragments in a single scan.

Reagents & Setup

- System: UHPLC coupled to Q-Exactive (Orbitrap) or Q-TOF.
- Mobile Phase A: 0.1% Formic Acid in Water (Proton source).[1]
- Mobile Phase B: 0.1% Formic Acid in Acetonitrile.
- Column: C18 Charged Surface Hybrid (CSH) – Crucial for peak shape of basic piperazines.

Step-by-Step Acquisition Method

- Source Optimization:
 - Set Spray Voltage to 3.5 kV.
 - Capillary Temp: 320°C (Ensure complete desolvation of the polar piperazine).
- Fragmentation Setup (The "Stepped" Strategy):
 - Do not use a single Collision Energy (CE).
 - Protocol: Apply Stepped NCE (Normalized Collision Energy) of 20, 35, 50.
 - Reasoning:

- 20 NCE: Preserves the molecular ion and labile metabolic conjugates (e.g., Glucuronides).
 - 35 NCE: Cleaves the Pyrazole-Piperazine linker (bond).
 - 50 NCE: Shatters the aromatic rings to generate fingerprint ions ().
- Data Processing:
 - Extract Ion Chromatogram (EIC) for the theoretical with 5 ppm window.
 - Filter MS/MS for the presence of the "Piperazine Signature" (m/z 56.0500, 70.0657).

Decision Logic for Isomer Differentiation

Regioisomerism (e.g., 1,3- vs 1,5-substitution on the pyrazole) is a common synthetic impurity. Use this logic flow:

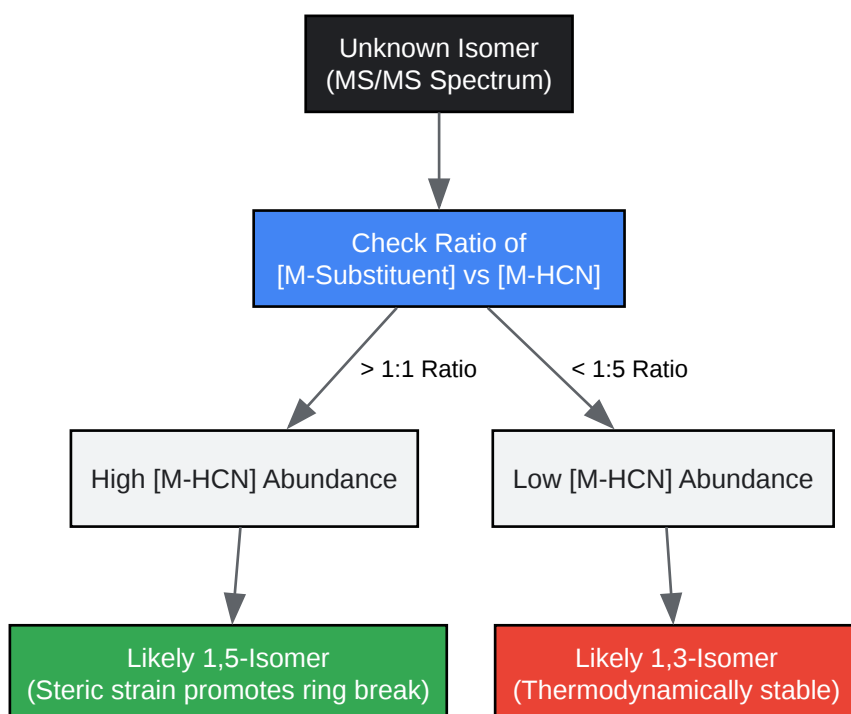

[Click to download full resolution via product page](#)

Figure 2: Logic flow for distinguishing pyrazole regioisomers based on fragmentation energetics.

Diagnostic Ion Reference Table

Use this table to validate your spectral assignments. Note: Exact masses are calculated based on

Fragment Structure	Nominal m/z	Exact Mass (m/z)	Origin/Mechanism
Piperazine Ring	86	86.0844	Intact piperazine (if N-unsubstituted).
Immonium Ion A	70	70.0651	Ring opening (Loss of or substituent).
Immonium Ion B	56	56.0495	Retro-Diels-Alder (Loss of).
Pyrazolyl Cation	Variable	Variable	Cleavage of linker; charge retention on aromatic ring.
Nitrile Fragment	Variable	[M-27]	Loss of HCN from Pyrazole ring (High Energy).

Conclusion

For the structural elucidation of pyrazolyl-piperazines, HCD (Stepped NCE 20-50) is the superior "product" compared to traditional CID. The elimination of the low-mass cutoff allows for the detection of the critical piperazine fingerprint ions (

56, 70), while the higher energy regime facilitates the ring-opening required to distinguish regioisomers. Researchers should adopt stepped-energy HCD protocols to ensure comprehensive coverage of both labile metabolites and stable scaffold backbones.

References

- Zhu, N., et al. "Mass Fragmentation Characteristics of Piperazine Analogues." [2] Journal of Chinese Mass Spectrometry Society, 2021. [2] 2
- BenchChem Application Notes. "Mass Spectrometry Fragmentation of Novel Piperidine Derivatives." BenchChem Technical Library, 2025. 3
- Welz, A., et al. "Rapid Targeted Method of Detecting Abused Piperazine Designer Drugs." [4] Journal of Clinical Medicine, 2021. 5
- Asif, N., et al. "Mass Spectrometry of Substituted 1H,6H-Pyrano[2,3-c]pyrazol-6-ones." [6][7] Asian Journal of Chemistry, 2013. [6] 6[4][7][8]
- Castiglioni, S., et al. "Fragmentation pathway of drugs of abuse and their metabolites using accurate mass spectra of QTOF MS." [9] CORE, 2024. 9[4][7][8]

Need Custom Synthesis?

BenchChem offers custom synthesis for rare earth carbides and specific isotopic labeling.

Email: info@benchchem.com or [Request Quote Online](#).

Sources

- 1. pdf.benchchem.com [pdf.benchchem.com]
- 2. [Mass Fragmentation Characteristics of Piperazine Analogues](https://zpxb.xml-journal.net) [zpxb.xml-journal.net]
- 3. pdf.benchchem.com [pdf.benchchem.com]
- 4. researchgate.net [researchgate.net]
- 5. [Rapid Targeted Method of Detecting Abused Piperazine Designer Drugs](https://mdpi.com) | MDPI [mdpi.com]
- 6. asianpubs.org [asianpubs.org]

- [7. researchgate.net \[researchgate.net\]](https://researchgate.net)
- [8. Regioselective Synthesis, Structural Characterization, and Antiproliferative Activity of Novel Tetra-Substituted Phenylaminopyrazole Derivatives - PMC \[pmc.ncbi.nlm.nih.gov\]](https://pubmed.ncbi.nlm.nih.gov/)
- [9. fileserv-az.core.ac.uk \[fileserv-az.core.ac.uk\]](https://fileserv-az.core.ac.uk)
- To cite this document: BenchChem. [Comparative Guide: HCD vs. CID Fragmentation for Pyrazolyl-Piperazine Structural Elucidation]. BenchChem, [2026]. [Online PDF]. Available at: [<https://www.benchchem.com/product/b12989054/docs#comparative-guide-hcd-vs-cid-fragmentation-for-pyrazolyl-piperazine-structural-elucidation>]

Disclaimer & Data Validity:

The information provided in this document is for Research Use Only (RUO) and is strictly not intended for diagnostic or therapeutic procedures. While BenchChem strives to provide accurate protocols, we make no warranties, express or implied, regarding the fitness of this product for every specific experimental setup.

Technical Support: The protocols provided are for reference purposes. Unsure if this reagent suits your experiment?

Need Industrial/Bulk Grade? [Request Custom Synthesis Quote](#)

BenchChem

Our mission is to be the trusted global source of essential and advanced chemicals, empowering scientists and researchers to drive progress in science and industry.

Contact

Address: 3281 E Guasti Rd
Ontario, CA 91761, United States
Phone: (601) 213-4426
Email: info@benchchem.com

[Contact our Ph.D. Support Team for a compatibility check](#)

