

Technical Support Center: Synthesis of 1-Chloro-3-fluorocyclohexane Isomers

Author: BenchChem Technical Support Team. **Date:** May 2026

Compound of Interest

Compound Name: 1-Chloro-3-fluorocyclohexane

Cat. No.: B12983427

[Get Quote](#)

Welcome to the technical support center for the synthesis of **1-chloro-3-fluorocyclohexane** isomers. This resource is designed for researchers, scientists, and drug development professionals to address common challenges encountered during the synthesis, purification, and characterization of these compounds.

Troubleshooting Guide

This guide addresses specific issues that may arise during the synthesis of **1-chloro-3-fluorocyclohexane** isomers, particularly when using diethylaminosulfur trifluoride (DAST) for the fluorination of 3-chlorocyclohexanol.

Issue	Possible Cause(s)	Suggested Solution(s)
Low or No Product Formation	1. Inactive DAST reagent.	1. Use a fresh bottle of DAST. The reagent can degrade over time, especially with improper storage.
2. Insufficient DAST.	2. Increase the equivalents of DAST. For secondary alcohols, 1.2-1.5 equivalents are typically recommended.	
3. Low reaction temperature.	3. Allow the reaction to warm to room temperature after the initial addition at low temperature (e.g., -78 °C). Some fluorinations require higher temperatures to proceed. ^[1]	
4. Presence of water in the reaction.	4. Ensure all glassware is flame-dried and the reaction is performed under an inert atmosphere (e.g., argon or nitrogen). Use anhydrous solvent.	
Low Yield of Desired Isomers	1. Formation of elimination byproducts (chlorocyclohexenes).	1. Maintain a low reaction temperature. Elimination is often favored at higher temperatures. Use a non-polar aprotic solvent like dichloromethane (DCM).
2. Formation of rearrangement byproducts.	2. DAST can promote cationic rearrangements. ^[2] This is less common for simple cyclohexanols but can be influenced by substrate structure. Consider alternative,	

less reactive fluorinating agents if this is a persistent issue.

3. Difficult purification leading to product loss.

3. Optimize the purification method. Flash chromatography with a carefully selected solvent system is often necessary to separate the isomers from byproducts.

Poor Stereoselectivity
(Unfavorable cis:trans ratio)

1. Reaction conditions favoring thermodynamic or kinetic products.

1. The stereochemical outcome of DAST fluorination typically proceeds with an inversion of configuration (SN2 mechanism).[3] The ratio of cis to trans isomers will depend on the stereochemistry of the starting 3-chlorocyclohexanol. To obtain a different isomer ratio, consider starting with a different stereoisomer of the alcohol.

2. Partial epimerization during the reaction.

2. This can occur if the reaction proceeds through an SN1-like mechanism. Lowering the reaction temperature and using a less polar solvent can favor the SN2 pathway.

Difficulty in Separating cis and trans Isomers

1. Similar polarities of the diastereomers.

1. Diastereomers can often be separated by flash column chromatography on silica gel. [4][5] Experiment with different solvent systems (e.g., varying ratios of ethyl acetate/hexanes) to find optimal separation.

-
2. Co-elution of isomers.
2. If silica gel chromatography is ineffective, consider alternative stationary phases such as alumina or reverse-phase C18 silica.[5] Preparative HPLC or GC may be necessary for high-purity separation.[4]
-

Frequently Asked Questions (FAQs)

Q1: What is the most common synthetic route to **1-chloro-3-fluorocyclohexane** isomers?

A1: The most common laboratory-scale synthesis involves the deoxofluorination of a corresponding 3-chlorocyclohexanol isomer using a fluorinating agent like diethylaminosulfur trifluoride (DAST).[2][3] This reaction replaces the hydroxyl group with a fluorine atom, typically with an inversion of stereochemistry.[3]

Q2: What are the primary safety concerns when working with DAST?

A2: DAST is a hazardous reagent that requires careful handling. It is toxic, corrosive, and can decompose violently upon heating.[1] It also reacts vigorously with water, releasing toxic hydrogen fluoride (HF) gas. All manipulations should be performed in a well-ventilated fume hood with appropriate personal protective equipment (PPE), including gloves, a lab coat, and safety glasses.

Q3: How can I control the stereochemical outcome of the fluorination?

A3: The fluorination of secondary alcohols with DAST generally proceeds through an SN2 mechanism, which results in an inversion of the stereochemistry at the carbon bearing the hydroxyl group.[3] Therefore, the stereochemistry of the resulting **1-chloro-3-fluorocyclohexane** isomers is primarily determined by the stereochemistry of the starting 3-chlorocyclohexanol. To obtain a specific isomer, you must start with the appropriate diastereomer of the alcohol.

Q4: My reaction is complete, but I am having trouble separating the cis and trans isomers. What should I do?

A4: The separation of diastereomers like cis- and trans-**1-chloro-3-fluorocyclohexane** can be challenging due to their similar physical properties.[5] Flash column chromatography on silica gel is the first method to try. You may need to screen various solvent systems with different polarities (e.g., gradients of ethyl acetate in hexanes) to achieve separation. If this fails, consider using a different stationary phase or a more advanced technique like preparative HPLC or GC.[4]

Q5: How can I confirm the identity and isomeric ratio of my products?

A5: A combination of analytical techniques is recommended. Gas chromatography-mass spectrometry (GC-MS) can be used to determine the presence of the desired product and any byproducts, as well as to quantify the isomeric ratio.[6] Nuclear magnetic resonance (NMR) spectroscopy (^1H , ^{13}C , and ^{19}F) is crucial for structural confirmation of the isomers. The coupling constants in the ^1H NMR spectrum can often help in distinguishing between the cis and trans isomers based on the axial or equatorial positions of the protons.

Experimental Protocols

Synthesis of **1-Chloro-3-fluorocyclohexane** Isomers from **3-Chlorocyclohexanol** using DAST

This protocol is a general guideline and may require optimization.

Materials:

- 3-chlorocyclohexanol (1.0 eq)
- Diethylaminosulfur trifluoride (DAST) (1.2-1.5 eq)
- Anhydrous dichloromethane (DCM)
- Saturated aqueous sodium bicarbonate (NaHCO_3) solution
- Brine

- Anhydrous sodium sulfate (Na_2SO_4)
- Silica gel for column chromatography
- Hexanes and ethyl acetate for elution

Procedure:

- In a flame-dried, three-neck round-bottom flask equipped with a magnetic stirrer, a dropping funnel, and a nitrogen inlet, dissolve 3-chlorocyclohexanol (1.0 eq) in anhydrous DCM.
- Cool the solution to $-78\text{ }^\circ\text{C}$ using a dry ice/acetone bath.
- Slowly add DAST (1.2-1.5 eq) dropwise to the stirred solution over 15-20 minutes.
- After the addition is complete, allow the reaction mixture to stir at $-78\text{ }^\circ\text{C}$ for one hour, then slowly warm to room temperature and stir for an additional 2-4 hours.
- Monitor the reaction progress by thin-layer chromatography (TLC) or GC-MS.
- Once the reaction is complete, carefully quench the reaction by slowly adding it to a stirred, ice-cold saturated aqueous NaHCO_3 solution.
- Separate the organic layer, and extract the aqueous layer with DCM (2 x 20 mL).
- Combine the organic layers, wash with brine, dry over anhydrous Na_2SO_4 , filter, and concentrate under reduced pressure.
- Purify the crude product by flash column chromatography on silica gel using a gradient of ethyl acetate in hexanes to separate the isomers.

Visualizations

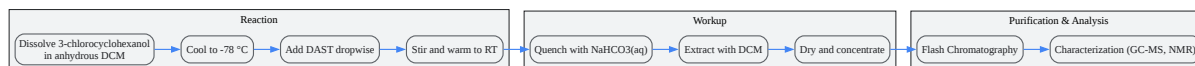

[Click to download full resolution via product page](#)

Caption: General experimental workflow for the synthesis and purification of **1-chloro-3-fluorocyclohexane** isomers.

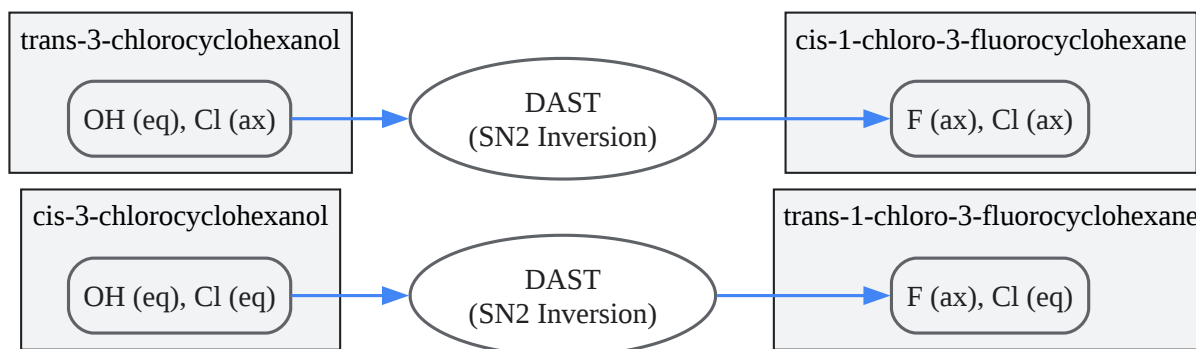

[Click to download full resolution via product page](#)

Caption: Stereochemical outcome of the DAST fluorination of 3-chlorocyclohexanol isomers.

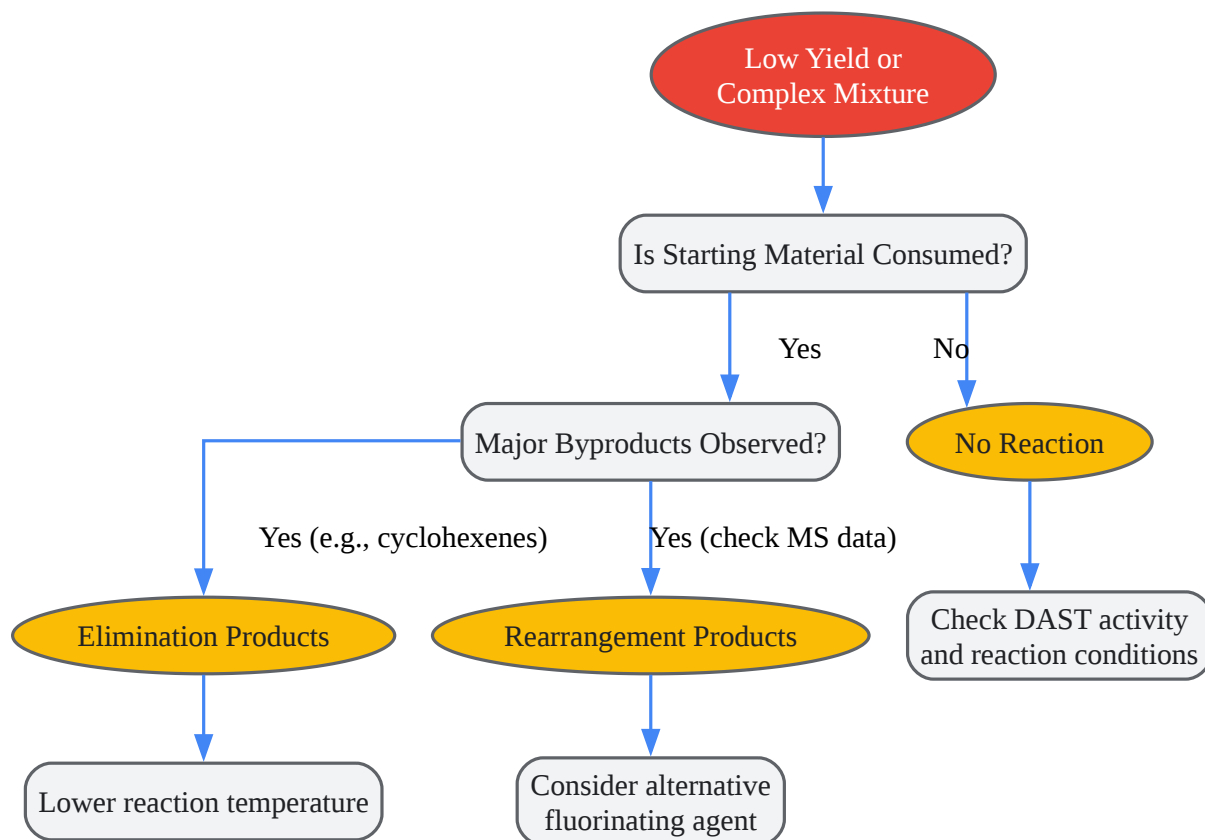

[Click to download full resolution via product page](#)

Caption: Troubleshooting decision tree for low yield in the synthesis of **1-chloro-3-fluorocyclohexane**.

Need Custom Synthesis?

BenchChem offers custom synthesis for rare earth carbides and specific isotopic labeling.

Email: info@benchchem.com or [Request Quote Online](#).

References

- 1. [Thieme E-Books & E-Journals \[thieme-connect.de\]](https://www.thieme-connect.de)

- [2. organic-synthesis.com \[organic-synthesis.com\]](#)
- [3. Enantiospecific deoxyfluorination of cyclic \$\alpha\$ -OH- \$\beta\$ -ketoesters† - PMC \[pmc.ncbi.nlm.nih.gov\]](#)
- [4. 1,3-Diaxial steric effects and intramolecular hydrogen bonding in the conformational equilibria of new cis-1,3-disubstituted cyclohexanes using low temperature NMR spectra and theoretical calculations - PubMed \[pubmed.ncbi.nlm.nih.gov\]](#)
- [5. EP2796439A1 - Method for purifying \(e\)-1-chloro-3,3,3-trifluoropropene - Google Patents \[patents.google.com\]](#)
- [6. Diethylaminosulfur Trifluoride \(DAST\) \[commonorganicchemistry.com\]](#)
- To cite this document: BenchChem. [Technical Support Center: Synthesis of 1-Chloro-3-fluorocyclohexane Isomers]. BenchChem, [2026]. [Online PDF]. Available at: [\[https://www.benchchem.com/product/b12983427/docs#technical-support-center-synthesis-of-1-chloro-3-fluorocyclohexane-isomers\]](https://www.benchchem.com/product/b12983427/docs#technical-support-center-synthesis-of-1-chloro-3-fluorocyclohexane-isomers)

Disclaimer & Data Validity:

The information provided in this document is for Research Use Only (RUO) and is strictly not intended for diagnostic or therapeutic procedures. While BenchChem strives to provide accurate protocols, we make no warranties, express or implied, regarding the fitness of this product for every specific experimental setup.

Technical Support: The protocols provided are for reference purposes. Unsure if this reagent suits your experiment?

Need Industrial/Bulk Grade? [Request Custom Synthesis Quote](#)

BenchChem

Our mission is to be the trusted global source of essential and advanced chemicals, empowering scientists and researchers to drive progress in science and industry.

Contact

Address: 3281 E Guasti Rd
Ontario, CA 91761, United States
Phone: (601) 213-4426
Email: info@benchchem.com

Contact our Ph.D. Support Team for a compatibility check