

# Introduction: The Strategic Importance of 3-(3-Chlorophenyl)propiophenone

**Author:** BenchChem Technical Support Team. **Date:** May 2026

## Compound of Interest

Compound Name: 3-(3-Chlorophenyl)propiophenone

CAS No.: 58122-03-5

Cat. No.: B1298397

[Get Quote](#)

**3-(3-Chlorophenyl)propiophenone**, also known as 3'-chloropropiophenone, is an aromatic ketone of significant interest in medicinal chemistry and organic synthesis. Its structure, featuring a propiophenone core with a chlorine atom at the meta position of the phenyl ring, makes it a versatile building block. This compound serves as a critical key intermediate in the synthesis of several active pharmaceutical ingredients (APIs), most notably Bupropion, an effective antidepressant and smoking cessation aid.<sup>[1][2][3][4]</sup> The chlorine substituent modifies the electronic properties of the molecule, influencing its reactivity and making it a valuable precursor for creating more complex molecular architectures, including chiral alcohols.<sup>[5][6]</sup>

This guide provides a comprehensive review of the primary synthetic pathways to **3-(3-Chlorophenyl)propiophenone**. It is designed to offer researchers and process chemists a detailed understanding of the available methodologies, from classic electrophilic aromatic substitutions to organometallic routes. Each pathway is examined through the lens of chemical mechanism, experimental protocol, and process viability, providing a robust framework for informed decision-making in a laboratory or manufacturing setting.

## Core Synthetic Strategies: A Comparative Overview

The synthesis of **3-(3-Chlorophenyl)propiophenone** can be broadly categorized into three primary strategies, each with distinct starting materials and reaction mechanisms. The choice of pathway often depends on factors such as raw material availability, cost, scalability, and desired purity profile.

- **Electrophilic Aromatic Substitution:** This class of reactions is the most traditional approach, involving the introduction of a functional group onto an aromatic ring.
  - **Friedel-Crafts Acylation of Chlorobenzene:** A direct approach where chlorobenzene is acylated to introduce the propionyl group.<sup>[5][6]</sup>
  - **Direct Chlorination of Propiophenone:** An alternative where the propiophenone core is synthesized first, followed by regioselective chlorination.<sup>[2][4][7]</sup>
- **Organometallic Synthesis (Grignard Reaction):** This powerful carbon-carbon bond-forming reaction utilizes a Grignard reagent to construct the ketone from a nitrile precursor.<sup>[2][4][8]</sup>
- **Alternative Pathways:** Less common but viable routes have also been developed from precursors like aminopropiophenone or chlorobenzoic acid.<sup>[7][9]</sup>

The following diagram illustrates the logical relationship between these core strategies.

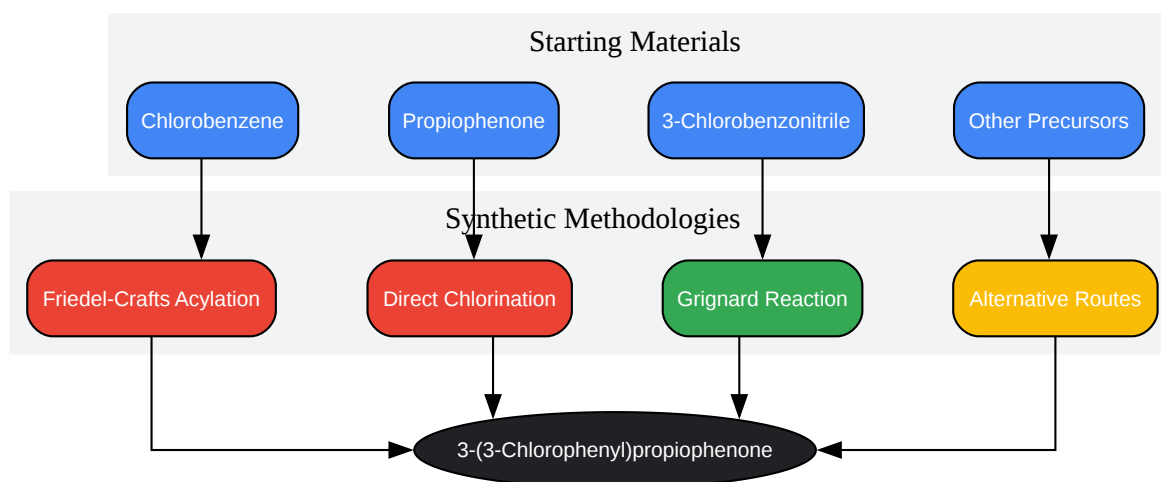

[Click to download full resolution via product page](#)

Caption: Overview of primary synthetic strategies.

## Pathway 1: Electrophilic Aromatic Substitution

### A. Friedel-Crafts Acylation of Chlorobenzene

The Friedel-Crafts acylation is a cornerstone of aromatic chemistry, enabling the direct installation of an acyl group onto a benzene ring.<sup>[10][11]</sup> In this context, chlorobenzene is reacted with an acylating agent, typically propionyl chloride, in the presence of a strong Lewis acid catalyst, most commonly aluminum chloride ( $\text{AlCl}_3$ ).

Mechanism: The reaction proceeds via the formation of a highly electrophilic acylium ion.<sup>[12]</sup>

- **Activation:** The Lewis acid ( $\text{AlCl}_3$ ) coordinates to the chlorine atom of propionyl chloride, polarizing the C-Cl bond and facilitating its cleavage.
- **Formation of Acylium Ion:** The departure of the  $[\text{AlCl}_4]^-$  complex generates a resonance-stabilized acylium ion ( $\text{CH}_3\text{CH}_2\text{C}=\text{O}^+$ ).
- **Electrophilic Attack:** The electron-rich  $\pi$ -system of the chlorobenzene ring attacks the acylium ion. The chloro group is an ortho-, para- director; however, the meta-product is the desired isomer and separation is often required.
- **Rearomatization:** A base (such as  $[\text{AlCl}_4]^-$ ) abstracts a proton from the intermediate sigma complex, restoring the aromaticity of the ring and yielding the final product.

The catalyst is required in stoichiometric amounts because it complexes with the resulting ketone product.<sup>[10]</sup>

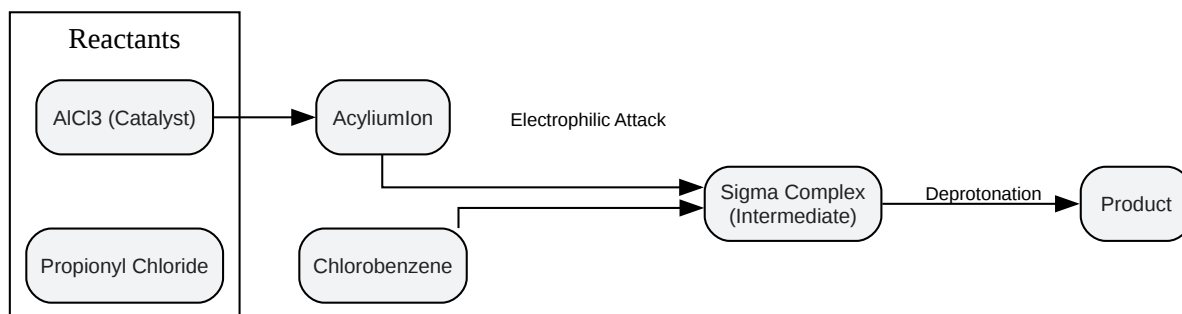

[Click to download full resolution via product page](#)

Caption: Friedel-Crafts acylation pathway.

## B. Direct Chlorination of Propiophenone

An alternative strategy involves the direct chlorination of propiophenone. This method leverages the relative ease of synthesizing the propiophenone core, followed by a regioselective halogenation step. The reaction is typically carried out by bubbling chlorine gas through a mixture of propiophenone and a Lewis acid catalyst, such as aluminum chloride.<sup>[2][7]</sup>

**Mechanism & Causality:** The aluminum chloride catalyst complexes with the carbonyl oxygen of propiophenone. This complexation deactivates the aromatic ring towards electrophilic attack and directs the incoming electrophile ( $\text{Cl}^+$ , generated from  $\text{Cl}_2$  and  $\text{AlCl}_3$ ) primarily to the meta-position. This is a critical aspect of this pathway's success, as it favors the desired 3-chloro isomer. The reaction can be performed in a solvent like 1,2-dichloroethane or, in some patented procedures, under solvent-free conditions, which offers significant environmental and cost advantages.<sup>[7][13]</sup> Yields for this method are reported to be high, often in the 88-90% range, with product purity exceeding 99.5% after purification.<sup>[7][13]</sup>

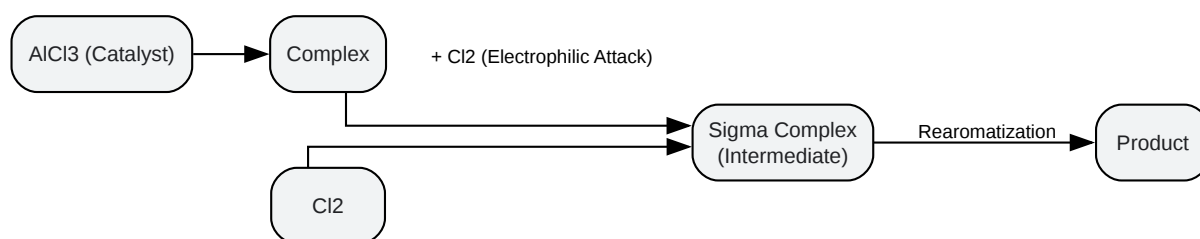

[Click to download full resolution via product page](#)

Caption: Direct chlorination of propiophenone.

## Pathway 2: Grignard Reaction with a Nitrile

The Grignard reaction provides a powerful and highly reliable method for constructing ketones. [14] For the synthesis of **3-(3-Chlorophenyl)propiophenone**, this involves the reaction of an ethylmagnesium halide (the Grignard reagent) with 3-chlorobenzonitrile. [2][4][8]

Mechanism & Causality:

- **Grignard Reagent Formation:** The process begins with the formation of the Grignard reagent, typically ethylmagnesium bromide, by reacting ethyl bromide with magnesium turnings in an anhydrous ether solvent like diethyl ether or tetrahydrofuran (THF). [14][15] The solvent is critical as it solvates and stabilizes the organomagnesium species. Anhydrous conditions are absolutely essential, as even trace amounts of water will protonate and destroy the highly basic Grignard reagent. [16][17]
- **Nucleophilic Attack:** The Grignard reagent acts as a potent source of a nucleophilic ethyl carbanion. This nucleophile attacks the electrophilic carbon of the nitrile group in 3-chlorobenzonitrile. [18]
- **Imine Intermediate Formation:** This addition breaks the carbon-nitrogen triple bond, forming an intermediate magnesium salt of an imine.
- **Hydrolysis:** The reaction is quenched with aqueous acid (e.g., HCl). This hydrolysis step protonates the imine, which is then readily hydrolyzed to the corresponding ketone, our target molecule. [6][8]

This method is advantageous for its high yields and predictability, but requires strict control of reaction conditions, particularly the exclusion of moisture.

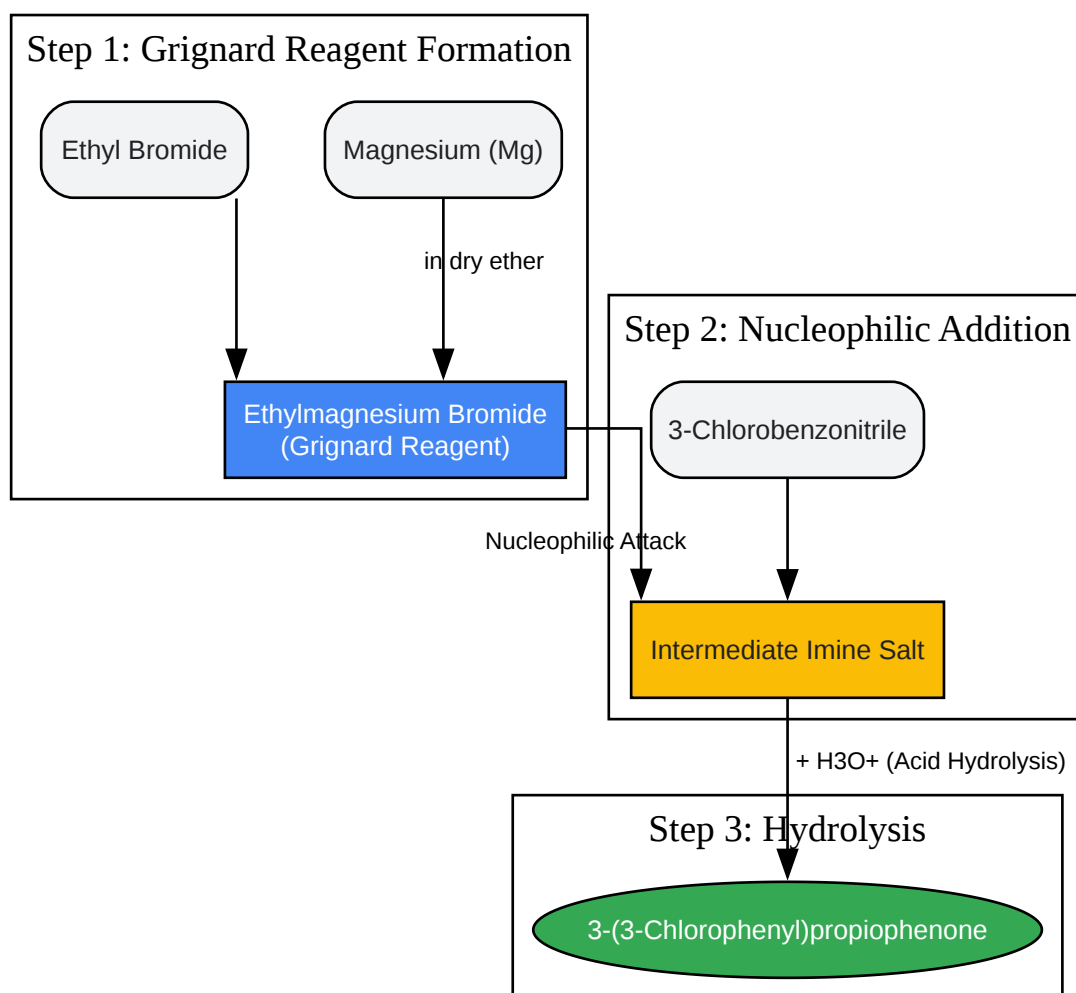

[Click to download full resolution via product page](#)

Caption: Grignard synthesis pathway.

## Quantitative Comparison of Synthesis Pathways

Synthesis Pathway	Starting Materials	Key Reagents / Catalyst	Reported Yield	Reported Purity	Key Advantages & Disadvantages
Direct Chlorination	Propiophenone, Chlorine (Cl <sub>2</sub> )	Aluminum Chloride (AlCl <sub>3</sub> )	88-90% <sup>[7]</sup>	99.7-99.9% <sup>[7]</sup>	(+): High yield & purity, potentially solvent-free. (-): Use of toxic chlorine gas.
Grignard Reaction	3-Chlorobenzonitrile, Ethyl Bromide, Magnesium	None (stoichiometric)	~92% (calculated from ref) <sup>[4]</sup>	~98% (crude crystals) <sup>[8]</sup>	(+): High yield, good for C-C bond formation. (-): Requires strictly anhydrous conditions, moisture sensitive.
From m-Aminopropiophenone	m-Aminopropiophenone	Sodium Nitrite, HCl, Cuprous Chloride	~60.5% <sup>[7]</sup>	90-95% <sup>[7]</sup>	(+): Utilizes a different precursor. (-): Lower yield, involves diazotization (potentially hazardous).
From m-Chlorobenzoinic Acid	m-Chlorobenzoinic Acid, Propionic Acid	Iron (Fe), Manganese Dioxide (MnO <sub>2</sub> )	~70% <sup>[9]</sup>	99.5% <sup>[9]</sup>	(+): Avoids harsh Lewis acids and organometallics. (-):

Requires high temperatures for decarboxylation.

---

## Detailed Experimental Protocols

### Protocol 1: Synthesis via Grignard Reaction (Adapted from PrepChem and ChemicalBook)[4][8]

Self-Validation: This protocol is self-validating through the visual confirmation of Grignard reagent formation (cloudy solution) and the formation of a precipitate upon addition of the nitrile, indicating a successful reaction prior to workup.

- **Apparatus Setup:** Assemble a three-necked round-bottom flask equipped with a reflux condenser, a pressure-equalizing dropping funnel, and a magnetic stirrer. All glassware must be rigorously dried overnight in an oven to remove all traces of water. The system is purged with dry nitrogen or argon gas.
- **Grignard Reagent Preparation:**
  - To the flask, add magnesium turnings (1.0 eq) and a small crystal of iodine (to initiate the reaction).
  - Add anhydrous diethyl ether or THF to cover the magnesium.
  - Prepare a solution of ethyl bromide (1.0 eq) in anhydrous ether in the dropping funnel.
  - Add a small portion of the ethyl bromide solution to the magnesium. The reaction should initiate, indicated by bubbling and a cloudy appearance. If it does not start, gently warm the flask.
  - Once initiated, add the remaining ethyl bromide solution dropwise at a rate that maintains a gentle reflux. After the addition is complete, continue to reflux for an additional 30-60 minutes to ensure all magnesium has reacted.

- Reaction with Nitrile:
  - Cool the Grignard reagent solution to room temperature.
  - Prepare a solution of 3-chlorobenzonitrile (0.6 eq, as the limiting reagent) in anhydrous ether.
  - Add the 3-chlorobenzonitrile solution dropwise to the stirred Grignard reagent. A precipitate will form.
  - Stir the mixture overnight at room temperature to ensure the reaction goes to completion.
- Hydrolysis and Workup:
  - Cool the reaction mixture in an ice bath.
  - Slowly and carefully add 3M aqueous hydrochloric acid (HCl) dropwise to quench the reaction and hydrolyze the intermediate imine salt. Continue adding acid until the solution is acidic (test with pH paper) and all solids have dissolved.
  - Transfer the mixture to a separatory funnel. Extract the aqueous layer with ethyl acetate or diethyl ether (2x).
  - Combine the organic extracts and wash with water, followed by a saturated sodium bicarbonate solution, and finally with brine. . Dry the organic layer over anhydrous magnesium sulfate or sodium sulfate, filter, and concentrate the solvent using a rotary evaporator.
- Purification: The resulting crude product (an orange oil or ochre crystals) can be purified by vacuum distillation or recrystallization to yield **3-(3-Chlorophenyl)propiophenone**.<sup>[7][8]</sup>

## Protocol 2: Synthesis via Direct Chlorination of Propiophenone (Adapted from CN1785952A)<sup>[7]</sup>

Self-Validation: The progress of this reaction can be monitored by GC analysis to determine the consumption of propiophenone and the formation of the product, ensuring the reaction proceeds to completion before hydrolysis.

- Apparatus Setup: Use a reaction vessel equipped with a stirrer, a gas inlet tube, a thermometer, and a gas outlet connected to a scrubber (e.g., a sodium hydroxide solution) to neutralize excess chlorine gas.
- Reaction Setup:
  - Charge the reactor with a solvent such as 1,2-dichloroethane, followed by anhydrous aluminum chloride ( $\text{AlCl}_3$ ) (1.1-1.5 eq).
  - Cool the mixture to below 20°C.
  - Add propiophenone (1.0 eq) slowly, maintaining the temperature below 20°C.
- Chlorination:
  - Begin bubbling chlorine gas ( $\text{Cl}_2$ ) through the stirred solution.
  - Maintain the reaction temperature between 13-18°C. The introduction of chlorine is an exothermic process and requires careful temperature control to ensure selectivity.
  - Continue the chlorine purge for approximately 3-4 hours, or until GC analysis indicates the reaction is complete.
- Hydrolysis and Workup:
  - Cool the reaction mixture.
  - Slowly pour the reaction mixture into a stirred mixture of crushed ice and concentrated hydrochloric acid for low-temperature hydrolysis. This step quenches the reaction and breaks up the aluminum chloride-ketone complex.
  - Transfer the mixture to a separatory funnel and separate the organic layer.
  - Wash the organic layer sequentially with dilute HCl, water, a 5% sodium carbonate solution (to remove any remaining acid), and finally with water until the washings are neutral.
- Purification:

- Dry the organic layer over an anhydrous drying agent.
- Remove the solvent by distillation.
- The crude product is then purified by vacuum distillation at 165-170°C to afford the final product with high purity.[7]

## Conclusion

The synthesis of **3-(3-Chlorophenyl)propiophenone** is well-established, with several robust and high-yielding pathways available to the modern chemist. The direct chlorination of propiophenone stands out for its high efficiency and potential for solvent-free conditions, making it attractive for industrial-scale production. The Grignard pathway offers a classic and reliable alternative, particularly suitable for laboratory-scale synthesis where the stringent anhydrous conditions can be carefully managed. The choice between these methods will ultimately be guided by a comprehensive analysis of process economics, safety considerations, environmental impact, and the specific purity requirements of the final application, particularly in the context of pharmaceutical development where regulatory standards are paramount.

## References

- Google Patents. CN1785952A - Method for preparing 3' -chloropropiophenone.
- PrepChem.com. Synthesis of 3'-chloropropiophenone. [[Link](#)]
- White Rose Research Online. A greener synthesis of the antidepressant bupropion hydrochloride. [[Link](#)]
- Jasperse, J. Grignard Reaction. [[Link](#)]
- National Center for Biotechnology Information. Deconstructed Analogues of Bupropion Reveal Structural Requirements for Transporter Inhibition versus Substrate-Induced Neurotransmitter Release. [[Link](#)]
- Quickcompany. Novel Process For The Preparation Of 3' Chloropropiophenone. [[Link](#)]
- National Center for Biotechnology Information. Synthesis and Characterization of In Vitro and In Vivo Profiles of Hydroxybupropion Analogues: Aids to Smoking Cessation. [[Link](#)]

- Google Patents. US7737302B2 - Process for preparing bupropion hydrochloride.
- ResearchGate. Study on synthesis of m-chloropropiophenone from m-chlorobenzoic acid and propionic acid. [[Link](#)]
- ResearchGate. (PDF) Hydroxybupropion- Synthesis and Characterization. [[Link](#)]
- Organic Chemistry Portal. Friedel-Crafts Acylation. [[Link](#)]
- Google Patents.
- Master Organic Chemistry. EAS Reactions (3) - Friedel-Crafts Acylation and Friedel-Crafts Alkylation. [[Link](#)]
- National Center for Biotechnology Information. Applications of Friedel–Crafts reactions in total synthesis of natural products. [[Link](#)]
- Chemistry LibreTexts. 16.3: Alkylation and Acylation of Aromatic Rings - The Friedel-Crafts Reaction. [[Link](#)]
- Chemistry Steps. Friedel-Crafts Acylation with Practice Problems. [[Link](#)]
- Chemistry LibreTexts. 7: The Grignard Reaction (Experiment). [[Link](#)]
- Master Organic Chemistry. Reactions of Grignard Reagents. [[Link](#)]
- University of California, Davis. Grignard Reaction: Synthesis of Triphenylmethanol. [[Link](#)]

#### ***Need Custom Synthesis?***

*BenchChem offers custom synthesis for rare earth carbides and specific isotopic labeling.*

*Email: [info@benchchem.com](mailto:info@benchchem.com) or [Request Quote Online](#).*

## Sources

- 1. [eprints.whiterose.ac.uk](https://eprints.whiterose.ac.uk) [[eprints.whiterose.ac.uk](https://eprints.whiterose.ac.uk)]
- 2. [Novel Process For The Preparation Of 3' Chloropropiophenone](#) [[quickcompany.in](#)]

- [3. Synthesis and Characterization of In Vitro and In Vivo Profiles of Hydroxybupropion Analogues: Aids to Smoking Cessation - PMC \[pmc.ncbi.nlm.nih.gov\]](#)
- [4. 3'-Chloropropiophenone synthesis - chemicalbook \[chemicalbook.com\]](#)
- [5. Buy 3-\(3-Chlorophenyl\)propiofenone | 58122-03-5 \[smolecule.com\]](#)
- [6. Page loading... \[guidechem.com\]](#)
- [7. CN1785952A - Method for preparing 3' -chloropropiophenone - Google Patents \[patents.google.com\]](#)
- [8. prepchem.com \[prepchem.com\]](#)
- [9. researchgate.net \[researchgate.net\]](#)
- [10. Friedel-Crafts Acylation \[organic-chemistry.org\]](#)
- [11. masterorganicchemistry.com \[masterorganicchemistry.com\]](#)
- [12. Friedel-Crafts Acylation with Practice Problems - Chemistry Steps \[chemistrysteps.com\]](#)
- [13. CN103360228A - Preparation method of amfebutamone intermediate m-chlorophenylacetone - Google Patents \[patents.google.com\]](#)
- [14. adichemistry.com \[adichemistry.com\]](#)
- [15. chem.libretexts.org \[chem.libretexts.org\]](#)
- [16. web.mnstate.edu \[web.mnstate.edu\]](#)
- [17. cerritos.edu \[cerritos.edu\]](#)
- [18. masterorganicchemistry.com \[masterorganicchemistry.com\]](#)
- [To cite this document: BenchChem. \[Introduction: The Strategic Importance of 3-\(3-Chlorophenyl\)propiofenone\]. BenchChem, \[2026\]. \[Online PDF\]. Available at: \[https://www.benchchem.com/product/b1298397/docs#introduction-the-strategic-importance-of-3-3-chlorophenyl-propiofenone\]](#)

---

### Disclaimer & Data Validity:

The information provided in this document is for Research Use Only (RUO) and is strictly not intended for diagnostic or therapeutic procedures. While BenchChem strives to provide accurate protocols, we make no warranties, express or implied, regarding the fitness of this product for every specific experimental setup.

**Technical Support:** The protocols provided are for reference purposes. Unsure if this reagent suits your experiment?

**Need Industrial/Bulk Grade?** [Request Custom Synthesis Quote](#)

## BenchChem

Our mission is to be the trusted global source of essential and advanced chemicals, empowering scientists and researchers to drive progress in science and industry.

### Contact

Address: 3281 E Guasti Rd  
Ontario, CA 91761, United States  
Phone: (601) 213-4426  
Email: [info@benchchem.com](mailto:info@benchchem.com)

[Contact our Ph.D. Support Team for a compatibility check](#)