

# An In-depth Technical Guide to Trityl Protecting Groups in Chemical Synthesis

**Author:** BenchChem Technical Support Team. **Date:** May 2026

## Compound of Interest

Compound Name: 4,4',4''-Trifluorotriyl Bromide

CAS No.: 200004-38-2

Cat. No.: B1298464

[Get Quote](#)

In the landscape of modern organic synthesis, the strategic use of protecting groups is a cornerstone of success, enabling chemists to navigate the complexities of multifunctional molecules.<sup>[1]</sup> Among the arsenal of available tools, the triphenylmethyl (trityl, Trt) group holds a distinguished position, valued for its unique combination of steric bulk, stability under basic and neutral conditions, and predictable acid lability.<sup>[1][2][3]</sup> This guide offers a comprehensive exploration of the trityl protecting group, its derivatives, and its strategic applications for professionals engaged in research, discovery, and drug development.

## Core Principles: The "Why" Behind the Trityl Group's Utility

The effectiveness of the trityl group is not accidental; it is a direct consequence of its distinct structure. Comprising three phenyl rings attached to a central carbon, the group is exceptionally bulky. This steric hindrance is a critical feature, not a drawback. It allows for the highly selective protection of primary alcohols over the more sterically congested secondary and tertiary alcohols.<sup>[1][2][3]</sup> This chemoselectivity is a foundational principle that synthetic chemists exploit to achieve precise control over reactivity in complex molecules like carbohydrates and nucleosides.<sup>[3]</sup>

Beyond alcohols, the trityl group is also adept at protecting other nucleophilic functional groups, including amines and thiols.[2][4] In the realm of peptide synthesis, it is frequently employed for the side-chain protection of amino acids such as cysteine, histidine, asparagine, and glutamine. [2]

## The Mechanism of Protection: A Tale of a Stable Cation

The introduction of a trityl group (tritylation) is not a direct SN2 displacement, a common misconception. Given the quaternary nature of the central carbon, an SN2 pathway is impossible.[5] Instead, the reaction proceeds through a unimolecular nucleophilic substitution (SN1)-type mechanism, a choice dictated by the extraordinary stability of the intermediate trityl carbocation.[2][3]

The process unfolds as follows:

- **Formation of the Trityl Cation:** The reaction is typically initiated with trityl chloride (TrCl) in the presence of a base like pyridine. Pyridine serves not only to neutralize the HCl byproduct but also facilitates the dissociation of the chloride, leading to the formation of the trityl cation.[3] [5] This carbocation is highly stabilized through the extensive resonance delocalization of the positive charge across the three phenyl rings.[2]
- **Nucleophilic Attack:** The target nucleophile, such as a primary alcohol, then attacks the electrophilic trityl cation to form the stable trityl ether.[2]

To accelerate this process, particularly for less reactive alcohols, a catalytic amount of 4-dimethylaminopyridine (DMAP) is often added. DMAP acts as a nucleophilic catalyst, first reacting with trityl chloride to form a more reactive N-tritylpyridinium intermediate, which is then more readily attacked by the alcohol.[2][5]

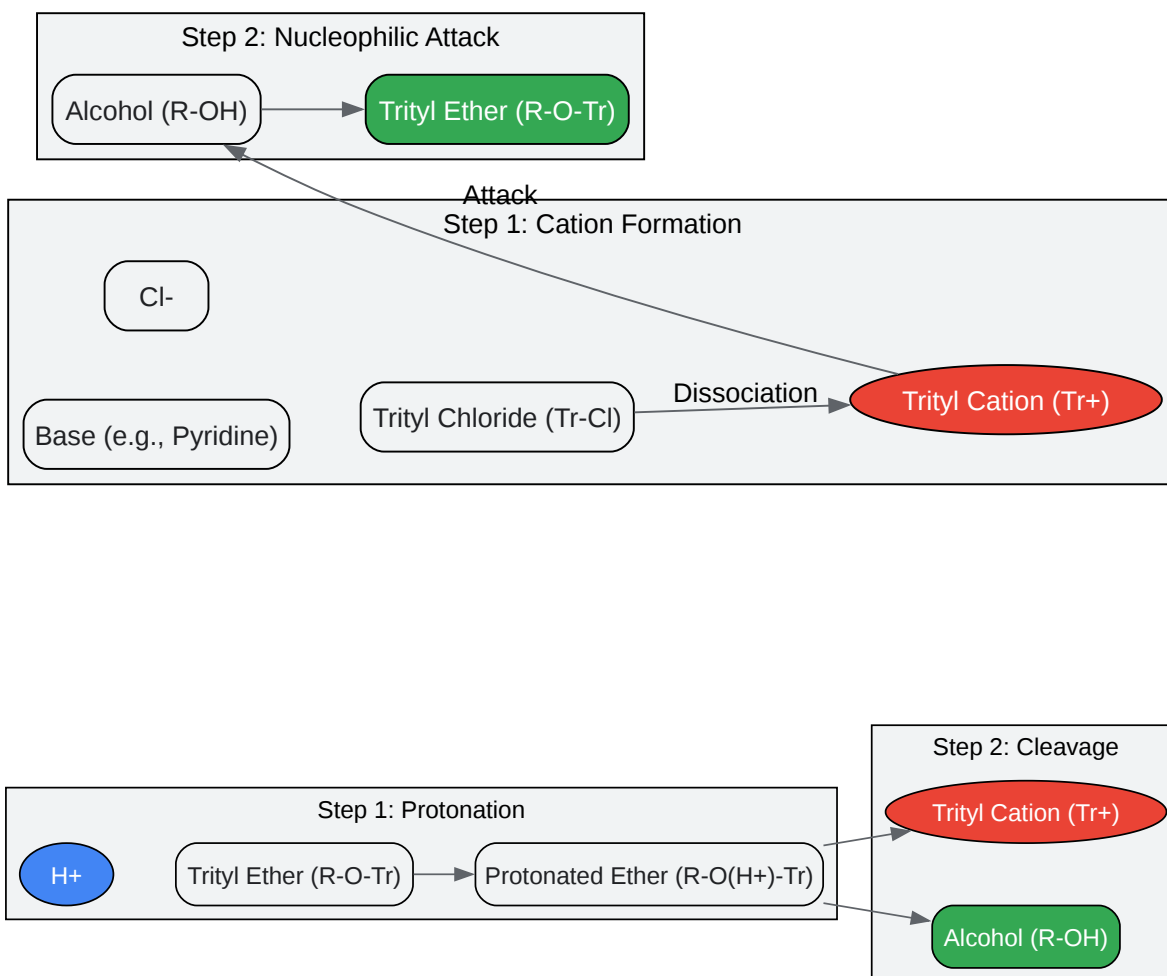

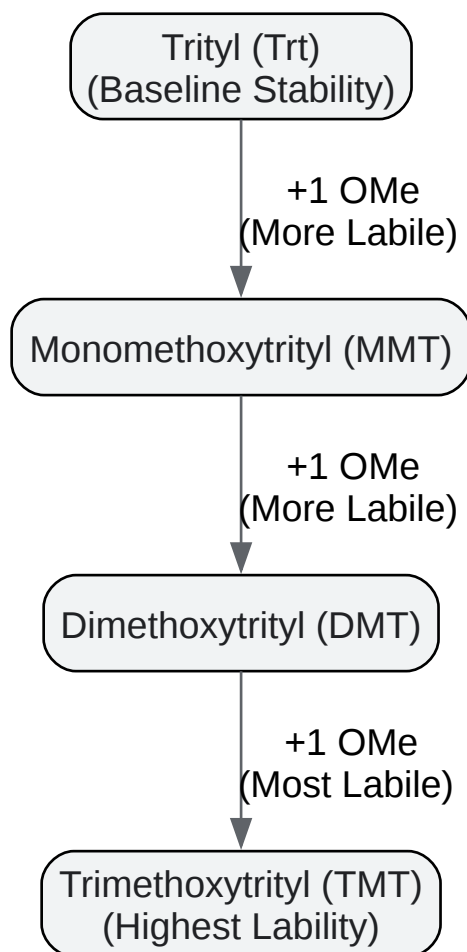

[Click to download full resolution via product page](#)

### Need Custom Synthesis?

BenchChem offers custom synthesis for rare earth carbides and specific isotopic labeling.

Email: [info@benchchem.com](mailto:info@benchchem.com) or [Request Quote Online](#).

## Sources

- [1. pdf.benchchem.com \[pdf.benchchem.com\]](https://pdf.benchchem.com)
- [2. pdf.benchchem.com \[pdf.benchchem.com\]](https://pdf.benchchem.com)
- [3. pdf.benchchem.com \[pdf.benchchem.com\]](https://pdf.benchchem.com)

- [4. acgpubs.org \[acgpubs.org\]](https://acgpubs.org)
- [5. total-synthesis.com \[total-synthesis.com\]](https://total-synthesis.com)
- To cite this document: BenchChem. [An In-depth Technical Guide to Trityl Protecting Groups in Chemical Synthesis]. BenchChem, [2026]. [Online PDF]. Available at: [\[https://www.benchchem.com/product/b1298464/docs#an-in-depth-technical-guide-to-trityl-protecting-groups-in-chemical-synthesis\]](https://www.benchchem.com/product/b1298464/docs#an-in-depth-technical-guide-to-trityl-protecting-groups-in-chemical-synthesis)

---

### Disclaimer & Data Validity:

The information provided in this document is for Research Use Only (RUO) and is strictly not intended for diagnostic or therapeutic procedures. While BenchChem strives to provide accurate protocols, we make no warranties, express or implied, regarding the fitness of this product for every specific experimental setup.

**Technical Support:** The protocols provided are for reference purposes. Unsure if this reagent suits your experiment?

**Need Industrial/Bulk Grade?** [Request Custom Synthesis Quote](#)

## BenchChem

Our mission is to be the trusted global source of essential and advanced chemicals, empowering scientists and researchers to drive progress in science and industry.

### Contact

Address: 3281 E Guasti Rd  
Ontario, CA 91761, United States  
Phone: (601) 213-4426  
Email: [info@benchchem.com](mailto:info@benchchem.com)

[Contact our Ph.D. Support Team for a compatibility check](#)