

# Scalable synthesis routes for 3-(2-Chlorophenyl)oxetane intermediates

**Author:** BenchChem Technical Support Team. **Date:** April 2026

## Compound of Interest

Compound Name: 3-(2-Chlorophenyl)oxetane

Cat. No.: B12975279

[Get Quote](#)

An Application Note from the Desk of a Senior Application Scientist

Topic: Scalable Synthesis Routes for **3-(2-Chlorophenyl)oxetane** Intermediates Audience: Researchers, scientists, and drug development professionals.

## Abstract

The oxetane ring is a highly valued structural motif in modern medicinal chemistry, prized for its ability to act as a polar and metabolically robust bioisostere for gem-dimethyl and carbonyl groups.[1][2][3] Its incorporation into drug candidates has been shown to favorably modulate key physicochemical properties such as aqueous solubility and metabolic stability.[4] This application note provides a detailed guide to two distinct and scalable synthetic strategies for preparing **3-(2-chlorophenyl)oxetane**, a key intermediate for drug discovery programs. We will explore a late-stage functionalization approach via Suzuki-Miyaura cross-coupling and a building-block strategy centered on the versatile oxetan-3-one. Each protocol is presented with detailed, step-by-step instructions, an analysis of the underlying chemical principles, and a discussion of scalability considerations to guide researchers from bench-scale synthesis to process development.

## The Strategic Value of the Oxetane Moiety

The four-membered oxetane heterocycle has emerged as a powerful tool in drug design.[4] Unlike the more strained and reactive epoxide ring, the oxetane core offers a unique combination of stability and advantageous physicochemical properties.[5][6] The strained C–O–C bond angle exposes the oxygen's lone pair of electrons, making the oxetane an excellent hydrogen-bond acceptor.[5] This polarity, combined with its compact, three-dimensional structure, allows it to improve aqueous solubility and escape lipophilic "logP space" when replacing less polar groups.

For drug development professionals, the synthesis of specifically substituted oxetanes, such as the 3-aryl variant, is of paramount importance. The **3-(2-chlorophenyl)oxetane** structure represents a common substitution pattern where the aryl group can engage in critical binding interactions with a biological target, while the oxetane fine-tunes the molecule's overall properties. However, the inherent ring strain (approximately 25.5 kcal/mol) makes the construction of the oxetane ring a significant synthetic challenge, requiring carefully considered strategies to achieve acceptable yields on a scalable basis.[1][6]

## Overview of Synthetic Strategies for 3-Aryloxetanes

Several methods have been developed for the synthesis of the oxetane core.[1] For industrial-scale production, the ideal route must be robust, high-yielding, and utilize readily available, cost-effective starting materials. Below is an overview of the principal strategies.

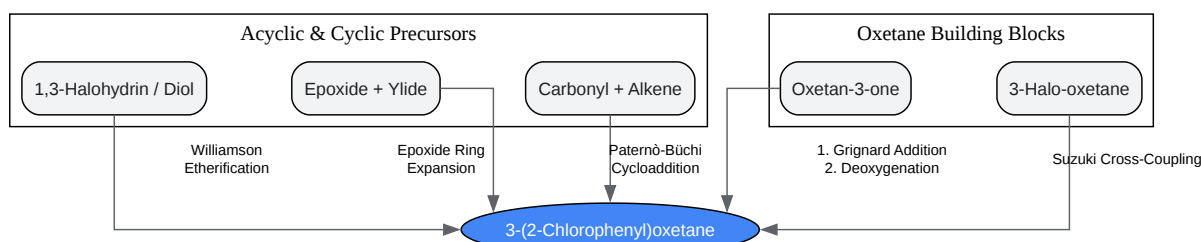

[Click to download full resolution via product page](#)

Caption: Major synthetic pathways to substituted oxetanes.

While methods like the Paternò-Büchi reaction have seen significant advances through the use of visible-light photocatalysis, they can present scalability challenges related to light penetration in large reactors.[4][7] Similarly, epoxide ring expansions are effective but may require the use of pyrophoric or thermally sensitive ylides.[2][6] Therefore, for the synthesis of **3-(2-chlorophenyl)oxetane**, we will focus on two of the most robust and scalable strategies: transition-metal-catalyzed cross-coupling and nucleophilic addition to a core oxetane building block.

## Recommended Scalable Protocols

The following protocols provide detailed methodologies for producing **3-(2-chlorophenyl)oxetane**. The choice between them depends on factors such as the availability of starting materials, cost considerations, and the desired scale of production.

### Protocol 1: Suzuki-Miyaura Cross-Coupling

This approach represents a convergent and highly modular synthesis. It relies on the nickel-catalyzed Suzuki coupling of a commercially available or readily synthesized 3-iodooxetane intermediate with 2-chlorophenylboronic acid.[5] This late-stage introduction of the aryl group is highly advantageous for creating libraries of analogues.

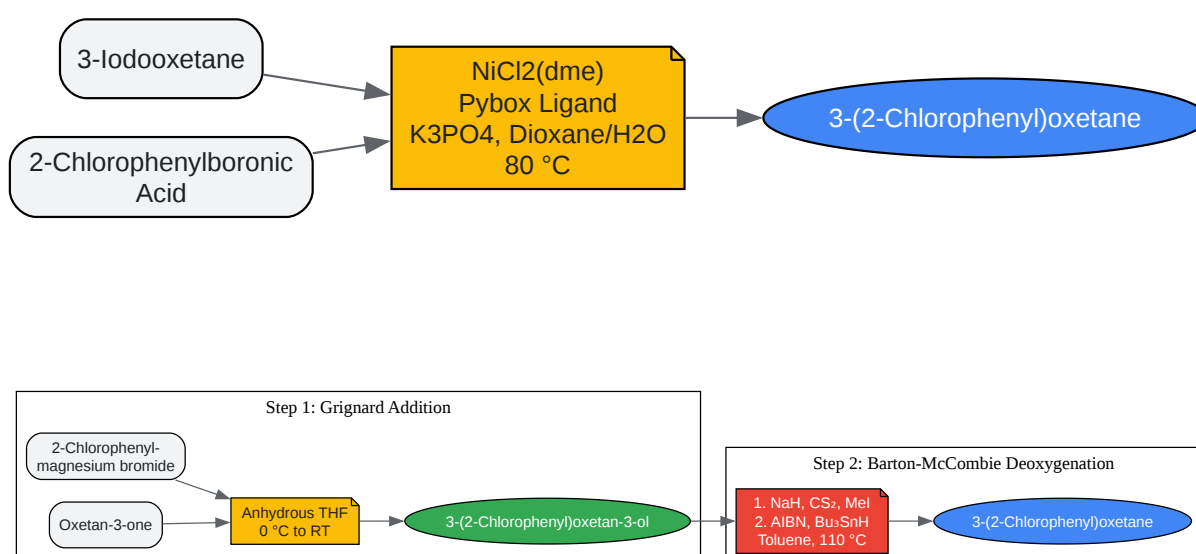

[Click to download full resolution via product page](#)

### Need Custom Synthesis?

BenchChem offers custom synthesis for rare earth carbides and specific isotopic labeling.

Email: [info@benchchem.com](mailto:info@benchchem.com) or [Request Quote Online](#).

## Sources

- 1. Oxetanes: formation, reactivity and total syntheses of natural products - PMC [[pmc.ncbi.nlm.nih.gov](https://pubmed.ncbi.nlm.nih.gov)]
- 2. BJOC - Oxetanes: formation, reactivity and total syntheses of natural products [[beilstein-journals.org](https://beilstein-journals.org)]
- 3. tandfonline.com [[tandfonline.com](https://tandfonline.com)]
- 4. pubs.acs.org [[pubs.acs.org](https://pubs.acs.org)]
- 5. pubs.acs.org [[pubs.acs.org](https://pubs.acs.org)]
- 6. d-nb.info [[d-nb.info](https://d-nb.info)]
- 7. chemrxiv.org [[chemrxiv.org](https://chemrxiv.org)]
- To cite this document: BenchChem. [Scalable synthesis routes for 3-(2-Chlorophenyl)oxetane intermediates]. BenchChem, [2026]. [Online PDF]. Available at: [<https://www.benchchem.com/product/b12975279/docs#scalable-synthesis-routes-for-3-2-chlorophenyl-oxetane-intermediates>]

---

### Disclaimer & Data Validity:

The information provided in this document is for Research Use Only (RUO) and is strictly not intended for diagnostic or therapeutic procedures. While BenchChem strives to provide accurate protocols, we make no warranties, express or implied, regarding the fitness of this product for every specific experimental setup.

**Technical Support:** The protocols provided are for reference purposes. Unsure if this reagent suits your experiment?

**Need Industrial/Bulk Grade?** [Request Custom Synthesis Quote](#)

# BenchChem

Our mission is to be the trusted global source of essential and advanced chemicals, empowering scientists and researchers to drive progress in science and industry.

## Contact

Address: 3281 E Guasti Rd  
Ontario, CA 91761, United States  
Phone: (601) 213-4426  
Email: [info@benchchem.com](mailto:info@benchchem.com)

[Contact our Ph.D. Support Team for a compatibility check](#)