

Technical Support Center: Derivatization with 2,4-Dimethoxyphenyl Isocyanate

Author: BenchChem Technical Support Team. **Date:** May 2026

Compound of Interest

Compound Name: 2,4-Dimethoxyphenyl isocyanate

CAS No.: 84370-87-6

Cat. No.: B1297688

[Get Quote](#)

Welcome to the technical support center for improving derivatization yields with **2,4-Dimethoxyphenyl isocyanate** (2,4-DMPI). This guide is designed for researchers, scientists, and drug development professionals to troubleshoot and optimize their derivatization reactions. The content is structured in a question-and-answer format to directly address specific issues encountered during experiments.

I. Frequently Asked Questions (FAQs)

Q1: What is **2,4-Dimethoxyphenyl isocyanate** and why is it used for derivatization?

A1: **2,4-Dimethoxyphenyl isocyanate** is a derivatizing agent used to modify analytes containing active hydrogen atoms, such as primary and secondary amines, phenols, and alcohols. The isocyanate group ($-N=C=O$) is highly electrophilic and reacts with nucleophilic functional groups to form stable urea or urethane linkages.^{[1][2]} This modification is often employed in analytical chemistry, particularly for liquid chromatography-mass spectrometry (LC-MS), to:

- **Enhance Ionization Efficiency:** The introduced moiety can improve the analyte's ability to be ionized in the mass spectrometer source, leading to increased sensitivity.[3][4]
- **Improve Chromatographic Separation:** Derivatization can alter the polarity and size of the analyte, leading to better peak shape and resolution during chromatographic separation.[4]
- **Increase Stability:** The resulting derivative may be more stable than the parent analyte under analytical conditions.

Q2: What is the fundamental reaction mechanism of 2,4-DMPI with analytes?

A2: The reaction proceeds via a nucleophilic addition mechanism. The nucleophilic atom (e.g., nitrogen in an amine or oxygen in a phenol/alcohol) attacks the electrophilic carbon atom of the isocyanate group.[2][5] A subsequent proton transfer results in the formation of a stable urea (from amines) or urethane (from alcohols/phenols) derivative. Electron-withdrawing groups on the isocyanate can increase the reactivity by making the carbon more electrophilic, while electron-donating groups, like the methoxy groups in 2,4-DMPI, can modulate this reactivity.[1]

Q3: Which functional groups will react with 2,4-DMPI?

A3: 2,4-DMPI will readily react with compounds containing active hydrogen atoms. The general order of reactivity with isocyanates is:

- Primary and Secondary Amines (forming ureas)
- Phenols (forming urethanes)
- Alcohols (forming urethanes)
- Thiols (forming thiocarbamates)
- Water (leading to hydrolysis and side products)[2]

It is crucial to be aware of all potential nucleophiles in your sample matrix, as they can compete with your target analyte for the derivatizing reagent.[6]

II. Troubleshooting Guide: Low Derivatization Yield

This section provides a systematic approach to diagnosing and resolving common issues leading to poor derivatization yields with 2,4-DMPI.

Problem 1: Low or No Product Formation

If you observe a very low signal for your derivatized product or none at all, consider the following potential causes and solutions.

Possible Cause 1: Reagent Degradation due to Moisture

- The "Why": Isocyanates are highly susceptible to hydrolysis.[6] Water reacts with the isocyanate group to form an unstable carbamic acid, which then decomposes into a primary amine (2,4-dimethoxyaniline in this case) and carbon dioxide.[7] This amine byproduct can then react with another molecule of 2,4-DMPI to form a symmetrical di-substituted urea, consuming your reagent and reducing the yield of your desired derivative.[6]
- Troubleshooting Steps:
 - Use Anhydrous Solvents: Ensure all solvents (e.g., acetonitrile, toluene, dichloromethane) are of anhydrous grade.[6] If necessary, dry the solvents using appropriate methods like distillation over a drying agent.
 - Proper Reagent Handling: Store 2,4-DMPI under an inert atmosphere (e.g., nitrogen or argon) and tightly sealed to prevent exposure to atmospheric moisture.
 - Reaction Setup: Conduct the derivatization in a dry reaction vessel, purged with an inert gas if possible.

Possible Cause 2: Suboptimal Reaction Conditions

- The "Why": Derivatization reactions are influenced by temperature, reaction time, and the solvent environment. The polarity of the solvent can significantly affect the reaction rate.[8]
- Troubleshooting Steps:
 - Optimize Temperature: While many derivatizations proceed at room temperature, gentle heating (e.g., 40-70°C) can often increase the reaction rate.[9][10][11] However, excessive

heat can promote side reactions like self-polymerization of the isocyanate.[6][12] Start with room temperature and incrementally increase if the yield is low.

- Optimize Reaction Time: The reaction may not be going to completion. Analyze aliquots at different time points (e.g., 15 min, 30 min, 60 min, 120 min) to determine the optimal reaction time for your specific analyte.[3][11]
- Solvent Selection: The choice of solvent can impact reaction kinetics. Aprotic solvents like acetonitrile, toluene, or dichloromethane are generally preferred.[13][14] Polar aprotic solvents like dimethyl sulfoxide (DMSO) or dimethylformamide (DMF) can also accelerate the reaction.[8][15]

Possible Cause 3: Incorrect Stoichiometry

- The "Why": An insufficient amount of the derivatizing agent will lead to an incomplete reaction.
- Troubleshooting Steps:
 - Use Molar Excess of 2,4-DMPI: It is common practice to use a molar excess of the derivatizing agent to drive the reaction to completion.[6] A starting point could be a 2 to 10-fold molar excess of 2,4-DMPI relative to the analyte.
 - Accurate Analyte Quantification: Ensure you have an accurate concentration of your starting material to calculate the correct stoichiometry.

Problem 2: Presence of Significant Side Products

If your analysis shows multiple peaks or a complex chromatogram, you may be generating unwanted side products.

Possible Cause 1: Reaction with Matrix Components

- The "Why": Your sample matrix may contain other nucleophilic compounds that compete with your target analyte for the 2,4-DMPI.[6]
- Troubleshooting Steps:

- Sample Cleanup: Implement a sample preparation step (e.g., solid-phase extraction (SPE) or liquid-liquid extraction (LLE)) to remove interfering compounds before derivatization.[16]
- Analyze a Matrix Blank: Derivatize a blank sample matrix (without the analyte) to identify potential interferences.

Possible Cause 2: Use of a Catalyst Leading to Side Reactions

- The "Why": While catalysts like tertiary amines (e.g., triethylamine, pyridine) or organotin compounds (e.g., dibutyltin dilaurate) can significantly increase the reaction rate, they can also promote side reactions, including the reaction of the isocyanate with water or its self-polymerization.[17][18][19]
- Troubleshooting Steps:
 - Optimize Catalyst Concentration: If using a catalyst, try reducing its concentration.
 - Attempt a Non-Catalyzed Reaction: For highly reactive analytes like primary amines, a catalyst may not be necessary.
 - Choose a Selective Catalyst: The choice of catalyst can influence which reaction is favored. For example, some catalysts may preferentially promote the isocyanate-hydroxyl reaction over the isocyanate-water reaction.[19]

III. Experimental Protocols & Data

General Protocol for Derivatization of Steroids with 2,4-DMPI for LC-MS/MS Analysis

This protocol is a general guideline and should be optimized for your specific steroid of interest. This is adapted from methodologies used for derivatizing hydroxyl and carbonyl groups on steroids.[16][20][21]

- Sample Preparation:
 - To 50 μ L of serum or plasma, add an internal standard.

- Perform a liquid-liquid extraction with 200 μL of methyl tert-butyl ether (MTBE). Vortex and centrifuge.
- Transfer the organic layer to a clean tube and evaporate to dryness under a gentle stream of nitrogen.
- Derivatization:
 - Reconstitute the dried extract in 50 μL of anhydrous acetonitrile.
 - Add 50 μL of a 1 mg/mL solution of 2,4-DMPI in anhydrous acetonitrile.
 - (Optional) Add 5 μL of a 1% solution of triethylamine in anhydrous acetonitrile as a catalyst.
 - Vortex briefly and incubate at 60°C for 30 minutes.[\[11\]](#)
- Sample Analysis:
 - After incubation, evaporate the solvent.
 - Reconstitute the sample in 100 μL of the initial mobile phase for LC-MS/MS analysis.

Table 1: Optimization of Derivatization Parameters

Parameter	Condition 1	Condition 2	Condition 3	Expected Outcome
Solvent	Toluene	Acetonitrile	Dimethyl Sulfoxide	Reaction rate increases with solvent polarity. [8]
Temperature	Room Temp (25°C)	50°C	70°C	Increased temperature generally increases reaction rate but may lead to side products above an optimal point. [9][10]
Catalyst	None	Triethylamine (TEA)	Dibutyltin dilaurate (DBTDL)	Catalysts increase reaction rate; DBTDL is often more active than tertiary amines. [18][19]
Reagent Molar Ratio (DMPI:Analyte)	2:1	5:1	10:1	Increasing excess of DMPI can drive the reaction to completion.

IV. Visual Guides

Workflow for Troubleshooting Low Derivatization Yield

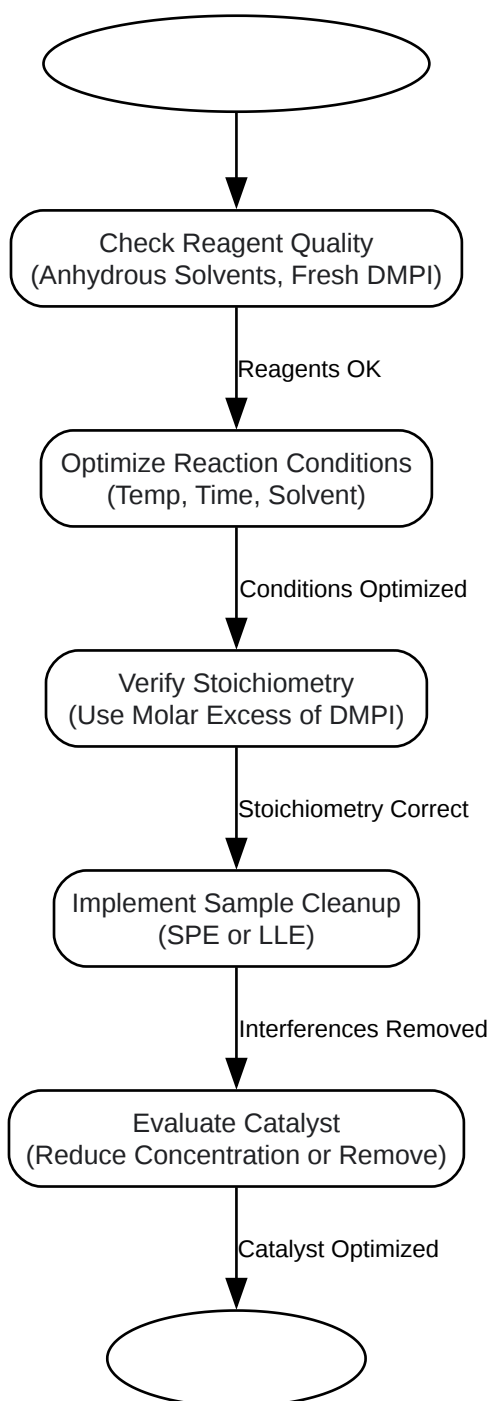

[Click to download full resolution via product page](#)

Caption: A decision tree for troubleshooting low derivatization yields.

Reaction Mechanism of 2,4-DMPI

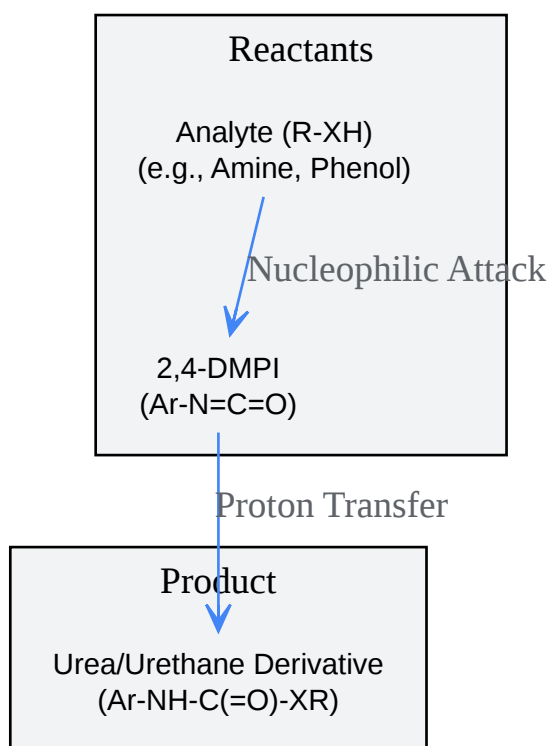

[Click to download full resolution via product page](#)

Caption: Nucleophilic addition of an analyte to 2,4-DMPI.

V. References

- Effect of solvent properties on reaction of isocyanates with mercaptans. (n.d.). ResearchGate. Retrieved January 11, 2026, from [\[Link\]](#)
- Catalysts. (n.d.). Poliuretanos. Retrieved January 11, 2026, from [\[Link\]](#)
- Effect of catalysts on the reaction of an aliphatic isocyanate and water. (2002). ResearchGate. Retrieved January 11, 2026, from [\[Link\]](#)
- The Reactions of Isocyanates and Isocyanate Derivatives at Elevated Temperatures. (n.d.). Semantic Scholar. Retrieved January 11, 2026, from [\[Link\]](#)
- Catalysis of the Isocyanate-Hydroxyl Reactions by Non-Tin Catalysts. (n.d.). Werner Blank. Retrieved January 11, 2026, from [\[Link\]](#)

- A novel LC-MS/MS method combined with derivatization for simultaneous quantification of vitamin D metabolites in human serum with diabetes as well as hyperlipidemia. (2023). National Institutes of Health. Retrieved January 11, 2026, from [\[Link\]](#)
- Isocyanate-based multicomponent reactions. (2024). National Institutes of Health. Retrieved January 11, 2026, from [\[Link\]](#)
- Comparison of Solvent/Derivatization Agent Systems for Determination of Extractable Toluene Diisocyanate from Flexible Polyurethane Foam. (2013). ResearchGate. Retrieved January 11, 2026, from [\[Link\]](#)
- Comparison of solvent/derivatization agent systems for determination of extractable toluene diisocyanate from flexible polyurethane foam. (2013). PubMed. Retrieved January 11, 2026, from [\[Link\]](#)
- Derivatization in Sample Preparation for LC-MS Bioanalysis. (n.d.). ResearchGate. Retrieved January 11, 2026, from [\[Link\]](#)
- Reactivity of organic isocyanates with nucleophilic compounds: Amines; Alcohols; Thiols; Oximes; And phenols in dilute organic solutions. (n.d.). ResearchGate. Retrieved January 11, 2026, from [\[Link\]](#)
- Enhanced LC-ESI-MS/MS Sensitivity by Cationic Derivatization of Organophosphorus Acids. (2023). MDPI. Retrieved January 11, 2026, from [\[Link\]](#)
- Parallel derivatization strategy coupled with liquid chromatography-mass spectrometry for broad coverage of steroid hormones. (2020). PubMed. Retrieved January 11, 2026, from [\[Link\]](#)
- The derivatization scheme involved in this paper: (A) steroid hormones... (n.d.). ResearchGate. Retrieved January 11, 2026, from [\[Link\]](#)
- Reactivity of Aliphatic and Phenolic Hydroxyl Groups in Kraft Lignin towards 4,4. (2021). Semantic Scholar. Retrieved January 11, 2026, from [\[Link\]](#)
- Effects of Solvent Polarity on the Reaction of Phenol with Toluene-2,4-Diisocyanate. (n.d.). ResearchGate. Retrieved January 11, 2026, from [\[Link\]](#)

- Schematic hydrolysis of an aromatic isocyanate and subsequent formation... (n.d.). ResearchGate. Retrieved January 11, 2026, from [[Link](#)]
- A sensitive approach for simultaneous quantification of carbonyl and hydroxyl steroids using 96-well SPE plates based on stable isotope coded-derivatization-UPLC-MRM: method development and application. (n.d.). National Institutes of Health. Retrieved January 11, 2026, from [[Link](#)]
- Overview of self-reactions of isocyanates and the resulting structural... (n.d.). ResearchGate. Retrieved January 11, 2026, from [[Link](#)]
- Quantitative-Profiling Method of Serum Steroid Hormones by Hydroxylamine-Derivatization HPLC–MS. (n.d.). National Institutes of Health. Retrieved January 11, 2026, from [[Link](#)]

Need Custom Synthesis?

BenchChem offers custom synthesis for rare earth carbides and specific isotopic labeling.

Email: info@benchchem.com or [Request Quote Online](#).

Sources

- [1. Isocyanate-based multicomponent reactions - PMC \[pmc.ncbi.nlm.nih.gov\]](#)
- [2. researchgate.net \[researchgate.net\]](#)
- [3. A novel LC-MS/MS method combined with derivatization for simultaneous quantification of vitamin D metabolites in human serum with diabetes as well as hyperlipidemia - PMC \[pmc.ncbi.nlm.nih.gov\]](#)
- [4. researchgate.net \[researchgate.net\]](#)
- [5. pdfs.semanticscholar.org \[pdfs.semanticscholar.org\]](#)
- [6. pdf.benchchem.com \[pdf.benchchem.com\]](#)
- [7. researchgate.net \[researchgate.net\]](#)
- [8. researchgate.net \[researchgate.net\]](#)
- [9. Enhanced LC-ESI-MS/MS Sensitivity by Cationic Derivatization of Organophosphorus Acids | MDPI \[mdpi.com\]](#)
- [10. pdf.benchchem.com \[pdf.benchchem.com\]](#)

- [11. Quantitative-Profiling Method of Serum Steroid Hormones by Hydroxylamine-Derivatization HPLC–MS - PMC \[pmc.ncbi.nlm.nih.gov\]](#)
- [12. The Reactions of Isocyanates and Isocyanate Derivatives at Elevated Temperatures | Semantic Scholar \[semanticscholar.org\]](#)
- [13. researchgate.net \[researchgate.net\]](#)
- [14. Comparison of solvent/derivatization agent systems for determination of extractable toluene diisocyanate from flexible polyurethane foam - PubMed \[pubmed.ncbi.nlm.nih.gov\]](#)
- [15. researchgate.net \[researchgate.net\]](#)
- [16. Parallel derivatization strategy coupled with liquid chromatography-mass spectrometry for broad coverage of steroid hormones - PubMed \[pubmed.ncbi.nlm.nih.gov\]](#)
- [17. poliuretanos.com.br \[poliuretanos.com.br\]](#)
- [18. researchgate.net \[researchgate.net\]](#)
- [19. wernerblank.com \[wernerblank.com\]](#)
- [20. researchgate.net \[researchgate.net\]](#)
- [21. A sensitive approach for simultaneous quantification of carbonyl and hydroxyl steroids using 96-well SPE plates based on stable isotope coded-derivatization-UPLC-MRM: method development and application - PMC \[pmc.ncbi.nlm.nih.gov\]](#)
- To cite this document: BenchChem. [Technical Support Center: Derivatization with 2,4-Dimethoxyphenyl Isocyanate]. BenchChem, [2026]. [Online PDF]. Available at: [\[https://www.benchchem.com/product/b1297688/docs#technical-support-center-derivatization-with-2-4-dimethoxyphenyl-isocyanate\]](https://www.benchchem.com/product/b1297688/docs#technical-support-center-derivatization-with-2-4-dimethoxyphenyl-isocyanate)

Disclaimer & Data Validity:

The information provided in this document is for Research Use Only (RUO) and is strictly not intended for diagnostic or therapeutic procedures. While BenchChem strives to provide accurate protocols, we make no warranties, express or implied, regarding the fitness of this product for every specific experimental setup.

Technical Support: The protocols provided are for reference purposes. Unsure if this reagent suits your experiment?

Need Industrial/Bulk Grade? [Request Custom Synthesis Quote](#)

BenchChem

Our mission is to be the trusted global source of essential and advanced chemicals, empowering scientists and researchers to drive progress in science and industry.

Contact

Address: 3281 E Guasti Rd

Ontario, CA 91761, United States

Phone: (601) 213-4426

Email: info@benchchem.com

[Contact our Ph.D. Support Team for a compatibility check](#)