

Synthesis of Propiophenone Derivatives: An Application Guide for Researchers

Author: BenchChem Technical Support Team. **Date:** May 2026

Compound of Interest

Compound Name:	2'-Fluoro-3'-(trifluoromethyl)propiophenone
CAS No.:	207986-23-0
Cat. No.:	B1297719

[Get Quote](#)

Propiophenone and its derivatives are pivotal structural motifs in organic synthesis, serving as crucial intermediates in the production of a wide array of pharmaceuticals, agrochemicals, and fragrances. Their versatile chemical nature allows for further functionalization, making them valuable building blocks in drug discovery and development. This application note provides a detailed guide for researchers, scientists, and drug development professionals on the experimental procedures for synthesizing propiophenone derivatives, with a focus on practical laboratory applications, mechanistic insights, and comparative analysis of common synthetic routes.

Strategic Approaches to Propiophenone Synthesis

The synthesis of propiophenones can be broadly categorized into several key strategies, each with its own merits and limitations. The choice of method often depends on the desired substitution pattern on the aromatic ring, the availability of starting materials, and the required scale of the synthesis. This guide will focus on three primary and widely applicable methods:

- **Friedel-Crafts Acylation:** A classic and direct method for forming the aryl ketone bond.

- Fries Rearrangement: An elegant method for synthesizing hydroxypropiophenones from phenolic esters.
- Two-Step Synthesis via Grignard Reaction and Oxidation: A versatile route that involves the creation of a secondary alcohol intermediate followed by its oxidation to the ketone.

Method 1: Friedel-Crafts Acylation

The Friedel-Crafts acylation is a cornerstone of aromatic chemistry, allowing for the direct introduction of an acyl group onto an aromatic ring.^[1] In the context of propiophenone synthesis, this involves the reaction of an aromatic compound with propionyl chloride or propionic anhydride in the presence of a Lewis acid catalyst, most commonly aluminum chloride (AlCl_3).^[2]

Mechanistic Rationale

The reaction proceeds via an electrophilic aromatic substitution mechanism. The Lewis acid catalyst activates the propionyl chloride by coordinating to the chlorine atom, which facilitates the formation of a highly electrophilic acylium ion. This ion is then attacked by the electron-rich aromatic ring, leading to the formation of a sigma complex (an arenium ion). Subsequent deprotonation of the sigma complex by a weak base restores the aromaticity of the ring and yields the propiophenone derivative.

The choice of a Lewis acid is critical; AlCl_3 is highly effective but must be used in stoichiometric amounts as it complexes with the product ketone.^[3] The reaction is generally irreversible, and the resulting ketone is less reactive than the starting aromatic compound, which prevents polyacylation.^[4]

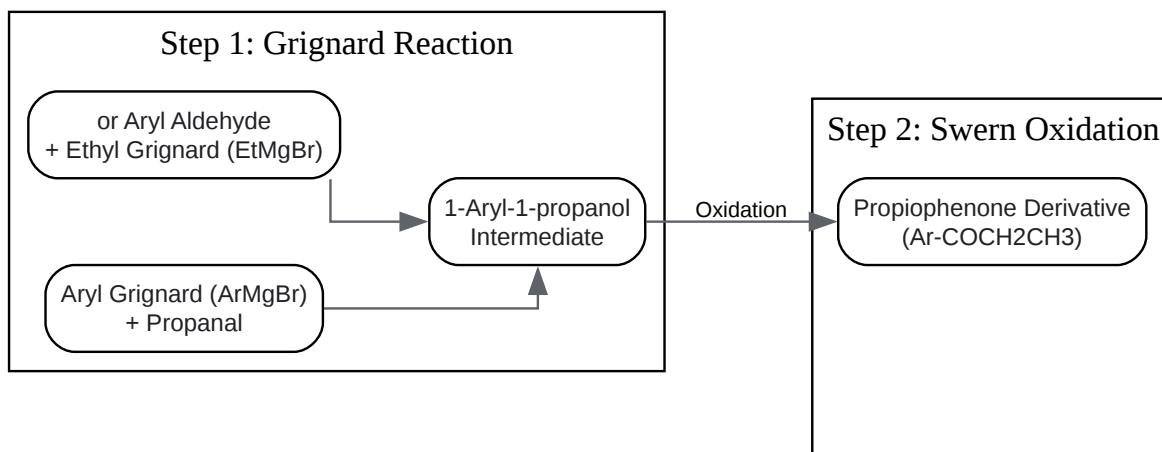
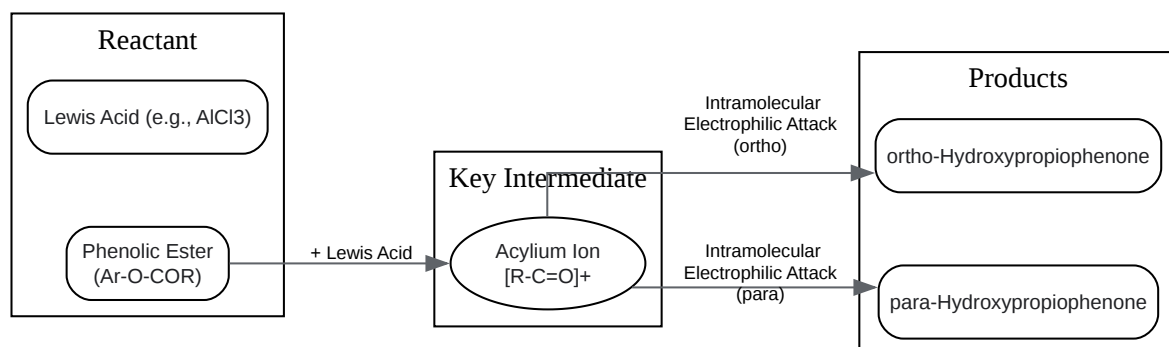
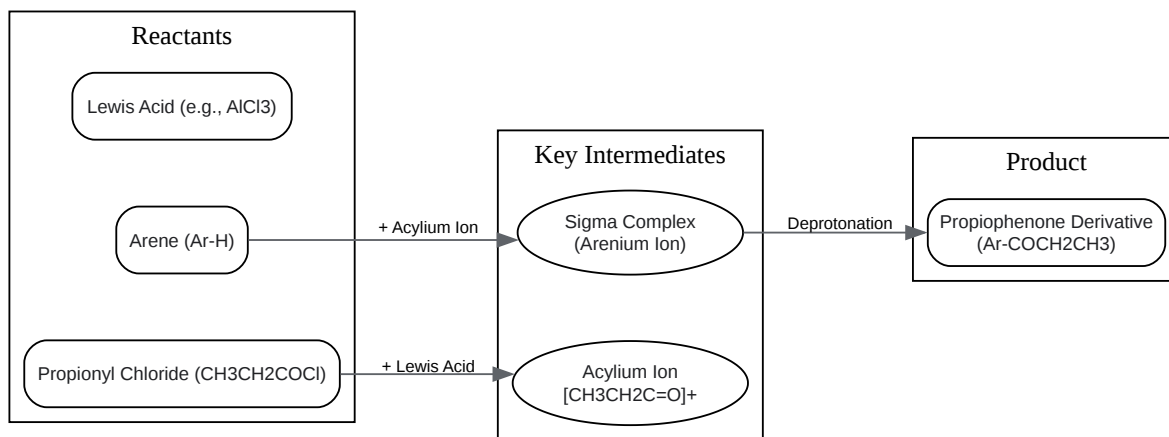

[Click to download full resolution via product page](#)

Need Custom Synthesis?

BenchChem offers custom synthesis for rare earth carbides and specific isotopic labeling.

Email: info@benchchem.com or [Request Quote Online](#).

Sources

- [1. researchgate.net](https://www.researchgate.net) [[researchgate.net](https://www.researchgate.net)]
- [2. chemconnections.org](https://www.chemconnections.org) [[chemconnections.org](https://www.chemconnections.org)]
- [3. researchgate.net](https://www.researchgate.net) [[researchgate.net](https://www.researchgate.net)]
- [4. m.youtube.com](https://www.youtube.com) [[m.youtube.com](https://www.youtube.com)]
- To cite this document: BenchChem. [Synthesis of Propiophenone Derivatives: An Application Guide for Researchers]. BenchChem, [2026]. [Online PDF]. Available at: [<https://www.benchchem.com/product/b1297719/docs#synthesis-of-propiophenone-derivatives-an-application-guide-for-researchers>]

Disclaimer & Data Validity:

The information provided in this document is for Research Use Only (RUO) and is strictly not intended for diagnostic or therapeutic procedures. While BenchChem strives to provide accurate protocols, we make no warranties, express or implied, regarding the fitness of this product for every specific experimental setup.

Technical Support: The protocols provided are for reference purposes. Unsure if this reagent suits your experiment?

Need Industrial/Bulk Grade? [Request Custom Synthesis Quote](#)

BenchChem

Our mission is to be the trusted global source of essential and advanced chemicals, empowering scientists and researchers to drive progress in science and industry.

Contact

Address: 3281 E Guasti Rd

Ontario, CA 91761, United States

Phone: (601) 213-4426

Email: info@benchchem.com

[Contact our Ph.D. Support Team for a compatibility check](#)