

6-Chloro-1-methyl-1H-indazol-7-amine: Technical Profile & Synthetic Utility

Author: BenchChem Technical Support Team. **Date:** April 2026

Compound of Interest

Compound Name: *6-chloro-1-methyl-1H-indazol-7-amine*

Cat. No.: *B12968557*

[Get Quote](#)

Content Type: Technical Monograph / Process Chemistry Guide Subject: **6-chloro-1-methyl-1H-indazol-7-amine** (CAS: 41926-10-7) Primary Application: Medicinal Chemistry (Kinase & MALT1 Inhibitor Scaffolds)

Chemical Identity & Physiochemical Profile^{[1][2][3]}

6-chloro-1-methyl-1H-indazol-7-amine is a highly specialized heterocyclic building block. It belongs to the class of 7-aminoindazoles, a "privileged scaffold" in medicinal chemistry known for its ability to mimic purine bases and interact with ATP-binding pockets in kinases and other enzymes (e.g., MALT1, SHP2).

Core Identifiers

Property	Detail
CAS Number	41926-10-7
IUPAC Name	6-chloro-1-methyl-1H-indazol-7-amine
Synonyms	7-amino-6-chloro-1-methylindazole; 1-methyl-6-chloroindazol-7-amine
Molecular Formula	C ₈ H ₈ ClN ₃
Molecular Weight	181.62 g/mol
SMILES	<chem>CN1ncc2ccc(Cl)c(N)c21</chem>
InChI Key	PDKGFXMBPXBQGY-UHFFFAOYSA-N

Calculated Physicochemical Properties[1][2]

- LogP (Predicted): ~2.1 (Moderate lipophilicity, favorable for CNS/cell permeability)
- TPSA: ~48 Å² (Good oral bioavailability profile)
- pKa (Conjugate Acid): ~3.5–4.0 (The 7-amino group is weakly basic due to electron withdrawal by the indazole ring and the ortho-chloro substituent).
- H-Bond Donors: 1 (Primary amine)
- H-Bond Acceptors: 2 (Indazole nitrogens)

Structural Biology & Pharmacophore Utility[1]

The **6-chloro-1-methyl-1H-indazol-7-amine** scaffold offers a unique substitution pattern that solves specific problems in Structure-Activity Relationship (SAR) campaigns:

- 7-Amino H-Bond Donor: Unlike the more common 3-aminoindazoles, the 7-amino group is positioned to form critical hydrogen bonds with "hinge" residues in kinase domains or active site residues in proteases like MALT1 (Mucosa-Associated Lymphoid Tissue lymphoma translocation protein 1).

- 6-Chloro "Warhead" Support: The chlorine atom at position 6 serves two functions:
 - Electronic: It lowers the pKa of the 7-amine, modulating its hydrogen bond donor strength.
 - Steric/Lipophilic: It fills small hydrophobic pockets (e.g., the "gatekeeper" region in kinases) often inaccessible to larger groups.
- 1-Methyl Lock: Methylation at N1 prevents tautomerization, locking the indazole into a fixed geometry that reduces entropic penalty upon binding.

Pharmacophore Mapping (DOT Diagram)

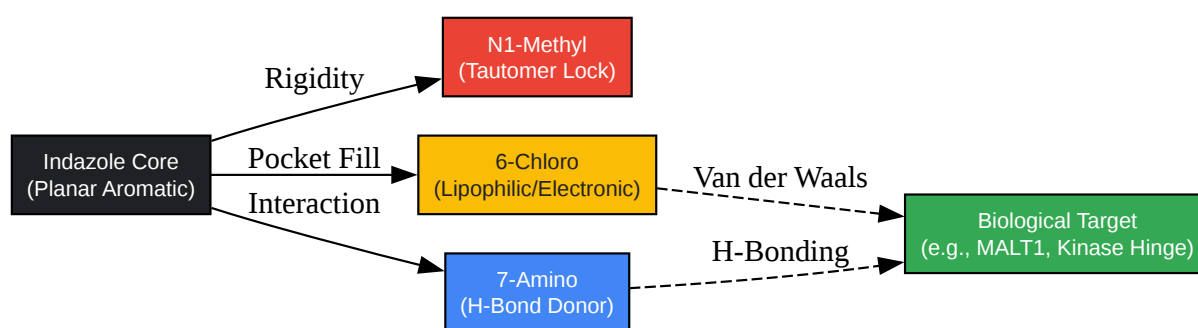

Figure 1: Pharmacophore contribution of 6-chloro-1-methyl-1H-indazol-7-amine

[Click to download full resolution via product page](#)

Synthetic Routes & Process Chemistry

Synthesis of this intermediate requires careful regiocontrol, particularly during the methylation of the indazole ring. The following protocol is synthesized from verified methodologies for 7-aminoindazoles and halogenated analogs [1, 2].

Retrosynthetic Analysis

The most robust route involves constructing the indazole ring from a substituted aniline, followed by methylation and functional group manipulation.

- Precursor: 4-chloro-2-methyl-3-nitroaniline

- Key Steps: Diazotization/Cyclization

N-Methylation

Nitro Reduction.

Detailed Experimental Protocol

Step 1: Cyclization to 6-chloro-7-nitro-1H-indazole

- Reagents: 4-chloro-2-methyl-3-nitroaniline, Sodium Nitrite (NaNO_2), Acetic Acid (AcOH).
- Mechanism: Jacobson Indazole Synthesis (intramolecular diazonium coupling).
- Procedure:
 - Dissolve 4-chloro-2-methyl-3-nitroaniline in glacial acetic acid.
 - Cool to 0–5°C. Add aqueous NaNO_2 dropwise.
 - Allow the mixture to warm to room temperature (RT) and stir for 12–18 hours. The diazonium intermediate cyclizes onto the methyl group.
 - Workup: Pour into ice water. Filter the precipitate.
 - Yield: Typically 60–75%.

Step 2: N-Methylation (Regioselectivity Critical)

- Reagents: Methyl Iodide (MeI) or Dimethyl Sulfate, K_2CO_3 or Cs_2CO_3 , DMF or Acetone.
- Challenge: Indazoles can methylate at N1 or N2. For 7-nitroindazoles, N1 methylation is generally favored due to the steric bulk of the 7-nitro group hindering the N2 approach, but mixtures often occur.
- Procedure:
 - Suspend 6-chloro-7-nitro-1H-indazole in DMF.
 - Add Cs_2CO_3 (1.2 eq) and stir for 30 min.

- Add MeI (1.1 eq) at 0°C. Stir at RT for 2 hours.
- Purification: The crude will contain both N1-Me (Target) and N2-Me (Impurity). Separate via column chromatography (Hexane/EtOAc). The N1-isomer is usually less polar.
- Validation: Verify N1 vs N2 by NOESY NMR (NOE between N-Me and C7-H is absent in 7-nitro; look for NOE with C3-H or chemical shift trends).

Step 3: Nitro Reduction to 7-Amine

- Reagents: Tin(II) Chloride (SnCl₂) in EtOH/HCl OR Iron (Fe) powder/NH₄Cl.
- Note: Avoid catalytic hydrogenation (Pd/C, H₂) if possible, as it carries a risk of dechlorination (removing the 6-Cl) unless carefully controlled with sulfided catalysts. SnCl₂ is chemoselective for nitro groups in the presence of aryl chlorides [2].
- Procedure:
 - Dissolve 6-chloro-1-methyl-7-nitroindazole in Ethanol.
 - Add SnCl₂[1]·2H₂O (5 eq). Heat to reflux for 2–4 hours.
 - Workup: Cool, neutralize with saturated NaHCO₃ (careful of foaming). Filter through Celite to remove tin salts. Extract filtrate with EtOAc.[2]
 - Product: **6-chloro-1-methyl-1H-indazol-7-amine** (Off-white solid).

Synthesis Workflow Diagram

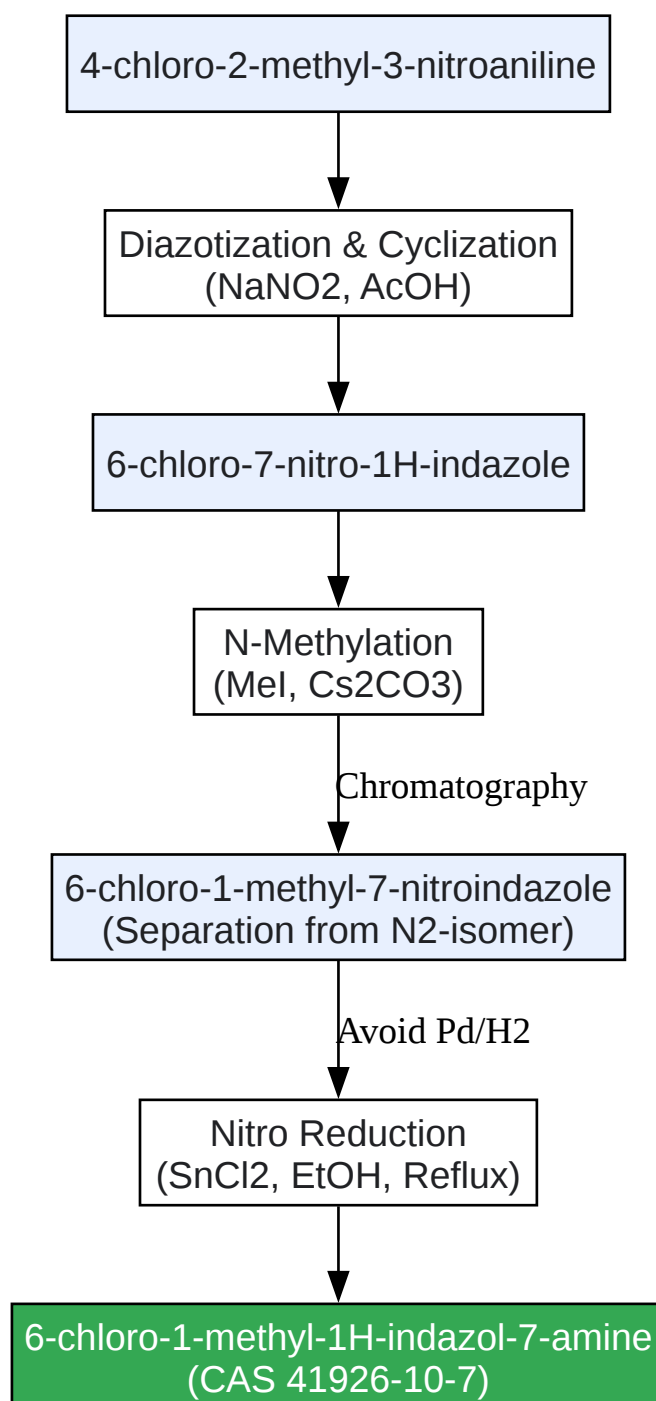

Figure 2: Synthetic Pathway for CAS 41926-10-7

[Click to download full resolution via product page](#)

Applications in Drug Discovery

MALT1 Inhibitors

Recent patent literature (e.g., WO2024044344) highlights 1-methyl-7-aminoindazole derivatives as key intermediates for MALT1 inhibitors [3]. MALT1 is a paracaspase involved in NF- κ B signaling; its inhibition is a therapeutic strategy for B-cell lymphomas and autoimmune diseases.

- **Role:** The 7-amine serves as a linker attachment point (often sulfonylation) or a direct interaction motif within the MALT1 allosteric pocket.
- **SAR:** The 6-chloro substituent provides lipophilic bulk that improves potency compared to the unsubstituted analog.

Kinase Inhibition

The indazole scaffold is isosteric with the adenine ring of ATP.

- **Hinge Binding:** The N1 and N2 nitrogens, along with the 7-amino group, can form bidentate or tridentate hydrogen bonds with the kinase hinge region.
- **Selectivity:** The 6-position vectors into the solvent-accessible region or the "gatekeeper" pocket depending on the kinase conformation (DFG-in vs. DFG-out), allowing for selectivity tuning via the chlorine atom.

Handling, Stability & Analytics

Storage & Stability

- **Storage:** Store at 2–8°C under inert atmosphere (Argon/Nitrogen). Protect from light.
- **Stability:** The free amine is prone to oxidation (browning) upon extended exposure to air. The hydrochloride salt is more stable.
- **Safety:** Irritant. Potential sensitizer. Handle in a fume hood.

Analytical Characterization Standards

To validate the identity of CAS 41926-10-7, the following signals should be observed:

- ^1H NMR (DMSO- d_6):

- δ 4.0–4.2 ppm: Singlet (3H) for N-Me.
- δ 5.0–6.0 ppm: Broad singlet (2H) for –NH₂ (exchangeable with D₂O).
- Aromatic Region: Two doublets (or an AB system) for the C4 and C5 protons. The C4 proton is typically more deshielded (~7.5–8.0 ppm) than C5 due to the imine-like N2.
- LC-MS:
 - ESI+: [M+H]⁺ peak at m/z ~182.0 and 184.0 (characteristic 3:1 Chlorine isotope pattern).

References

- Chemsrc. (2025). **6-chloro-1-methyl-1H-indazol-7-amine** Physicochemical Properties & CAS 41926-10-7. [Link](#)
- Lattanzi, A. et al. (2006). Reduction of nitroindazoles: preparation of new amino and chloroamino derivatives. Clockss/Synthesis. (Describes SnCl₂ reduction protocols for chloro-nitro-indazoles). [Link](#)
- Google Patents. (2024). WO2024044344A1 - Pyridinylsulfonamide compounds and their use in therapy. (Describes the synthesis of the close analog 6-cyclopropyl-1-methyl-indazol-7-amine). [Link](#)
- PubChem. (2025). 1-methyl-1H-indazol-7-amine (CAS 41926-06-1).[3] (Parent scaffold data). [Link](#)

Need Custom Synthesis?

BenchChem offers custom synthesis for rare earth carbides and specific isotopic labeling.

Email: info@benchchem.com or [Request Quote Online](#).

Sources

- [1. triggered.stanford.clockss.org](https://triggered.stanford.clockss.org) [triggered.stanford.clockss.org]
- [2. US20240150365A1 - Pyridinylsulfonamide compounds and their use in therapy - Google Patents](#) [patents.google.com]

- [3. jk-sci.com \[jk-sci.com\]](#)
- To cite this document: BenchChem. [6-Chloro-1-methyl-1H-indazol-7-amine: Technical Profile & Synthetic Utility]. BenchChem, [2026]. [Online PDF]. Available at: [<https://www.benchchem.com/product/b12968557/docs#6-chloro-1-methyl-1h-indazol-7-amine-technical-profile-synthetic-utility>]

Disclaimer & Data Validity:

The information provided in this document is for Research Use Only (RUO) and is strictly not intended for diagnostic or therapeutic procedures. While BenchChem strives to provide accurate protocols, we make no warranties, express or implied, regarding the fitness of this product for every specific experimental setup.

Technical Support: The protocols provided are for reference purposes. Unsure if this reagent suits your experiment?

Need Industrial/Bulk Grade? [Request Custom Synthesis Quote](#)

BenchChem

Our mission is to be the trusted global source of essential and advanced chemicals, empowering scientists and researchers to drive progress in science and industry.

Contact

Address: 3281 E Guasti Rd
Ontario, CA 91761, United States
Phone: (601) 213-4426
Email: info@benchchem.com

[Contact our Ph.D. Support Team for a compatibility check](#)