

Isoscabertopin: Application Notes and Protocols for Experimental Use

Author: BenchChem Technical Support Team. **Date:** April 2026

Compound of Interest

Compound Name: *Isoscabertopin*

Cat. No.: *B12966400*

[Get Quote](#)

For Researchers, Scientists, and Drug Development Professionals

Introduction

Isoscabertopin, a sesquiterpene lactone isolated from plants of the *Elephantopus* genus, has garnered interest within the scientific community for its potential anti-tumor properties. This document provides detailed application notes and protocols for the experimental use of **isoscabertopin**, focusing on its solubility, stability, and application in cell-based assays. The information herein is intended to guide researchers in designing and executing robust experiments to investigate the biological activities of this compound.

Solubility and Stability

Precise quantitative solubility data for **isoscabertopin** in common laboratory solvents is not readily available in the public domain. However, based on the known characteristics of sesquiterpene lactones, the following guidelines are provided for preparing stock solutions for in vitro experiments.

Solubility Guidelines:

Isoscabertopin is expected to be soluble in organic solvents such as dimethyl sulfoxide (DMSO) and ethanol. It is poorly soluble in aqueous solutions.

- Dimethyl Sulfoxide (DMSO): DMSO is the recommended solvent for creating high-concentration stock solutions of **isoscabertopin**. For cell-based assays, it is crucial to ensure the final concentration of DMSO in the culture medium is non-toxic to the cells, typically below 0.5%.
- Ethanol: Ethanol can also be used to dissolve **isoscabertopin**. Similar to DMSO, the final concentration in cell culture should be kept low to avoid solvent-induced cytotoxicity.

Stock Solution Preparation (General Protocol):

- Weigh out the desired amount of **isoscabertopin** powder in a sterile microcentrifuge tube.
- Add the appropriate volume of 100% DMSO or absolute ethanol to achieve the desired stock concentration (e.g., 10 mM, 20 mM, or 50 mM).
- Vortex thoroughly until the compound is completely dissolved. Gentle warming in a 37°C water bath may aid dissolution.
- Sterilize the stock solution by filtering it through a 0.22 µm syringe filter into a sterile tube.
- Store the stock solution at -20°C or -80°C in small aliquots to avoid repeated freeze-thaw cycles.

Stability Considerations:

The stability of **isoscabertopin** in solution is an important factor for ensuring the reproducibility of experimental results.

- pH and Temperature: Sesquiterpene lactones can be sensitive to pH and temperature. Some studies on related compounds suggest better stability at a slightly acidic pH (e.g., 5.5) compared to a neutral pH of 7.4, especially at 37°C.[\[1\]](#)[\[2\]](#)
- Ethanolic Solutions: Long-term storage of sesquiterpene lactones in ethanolic solutions may lead to degradation, a process that can be accelerated by higher temperatures.[\[3\]](#)[\[4\]](#)

- Aqueous Solutions: **Isoscabertopin** is expected to have limited stability in aqueous culture media. It is recommended to prepare fresh dilutions from the frozen stock solution for each experiment.

Biological Activity and Quantitative Data

Isoscabertopin and its related compounds, deoxyelephantopin and isodeoxyelephantopin, have demonstrated cytotoxic effects against a variety of cancer cell lines. The half-maximal inhibitory concentration (IC50) is a key parameter for quantifying this activity.

Compound	Cell Line	Cancer Type	IC50 Value	Citation
Scabertopin	J82	Bladder Cancer	Significantly lower than on normal cells	[5]
T24	Bladder Cancer	Bladder Cancer	Significantly lower than on normal cells	
RT4	Bladder Cancer	Bladder Cancer	Significantly lower than on normal cells	
5637	Bladder Cancer	Bladder Cancer	Significantly lower than on normal cells	
Deoxyelephantopin	HCT116	Colorectal Cancer	0.73 µg/mL (2.12 µM)	
K562	Chronic Myeloid Leukemia		4.02 µg/mL	
KB	Oral Cancer		3.35 µg/mL	
T47D	Breast Cancer		1.86 µg/mL	
L-929	Tumor Cell Line		11.2 µg/mL	
Isodeoxyelephantopin	HCT116	Colorectal Cancer	0.88 µg/mL (2.56 µM)	

Note: The study on scabertopin did not provide specific IC50 values but emphasized its selective toxicity towards bladder cancer cells over normal human ureteral epithelial immortalized cells (SV-HUC-1).

Signaling Pathways

Research on **isoscabertopin** and its analogs suggests that their anti-cancer effects are mediated through the modulation of multiple intracellular signaling pathways, primarily the NF- κ B, MAPK, and FAK/PI3K/Akt pathways.

NF- κ B Signaling Pathway

The NF- κ B pathway is a critical regulator of inflammation, cell proliferation, and survival. In many cancers, this pathway is constitutively active. Deoxyelephantopin and isodeoxyelephantopin have been shown to inhibit the NF- κ B signaling pathway.

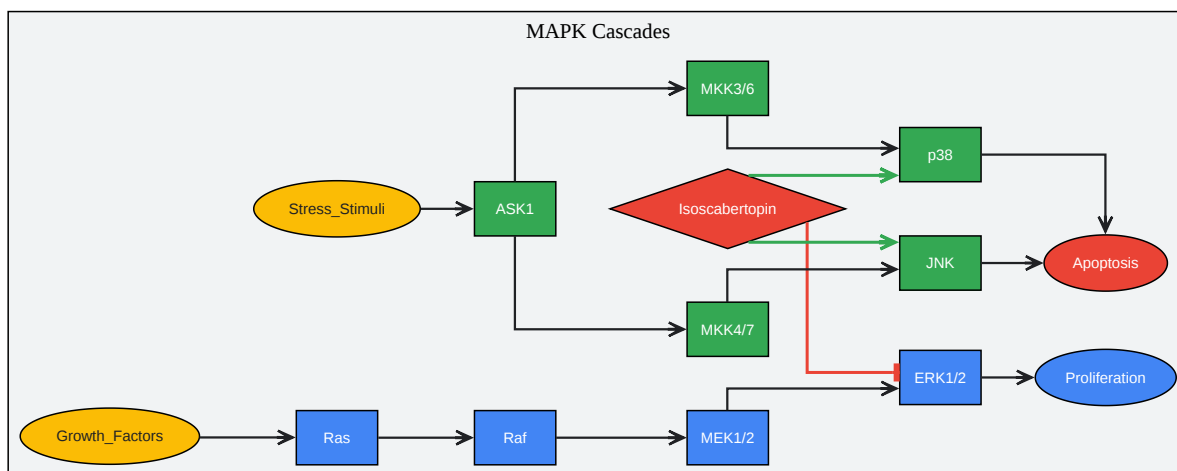
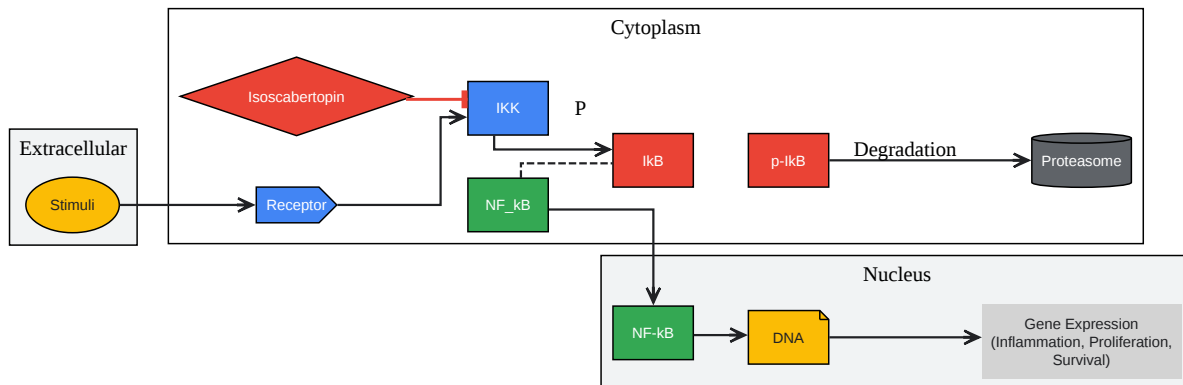

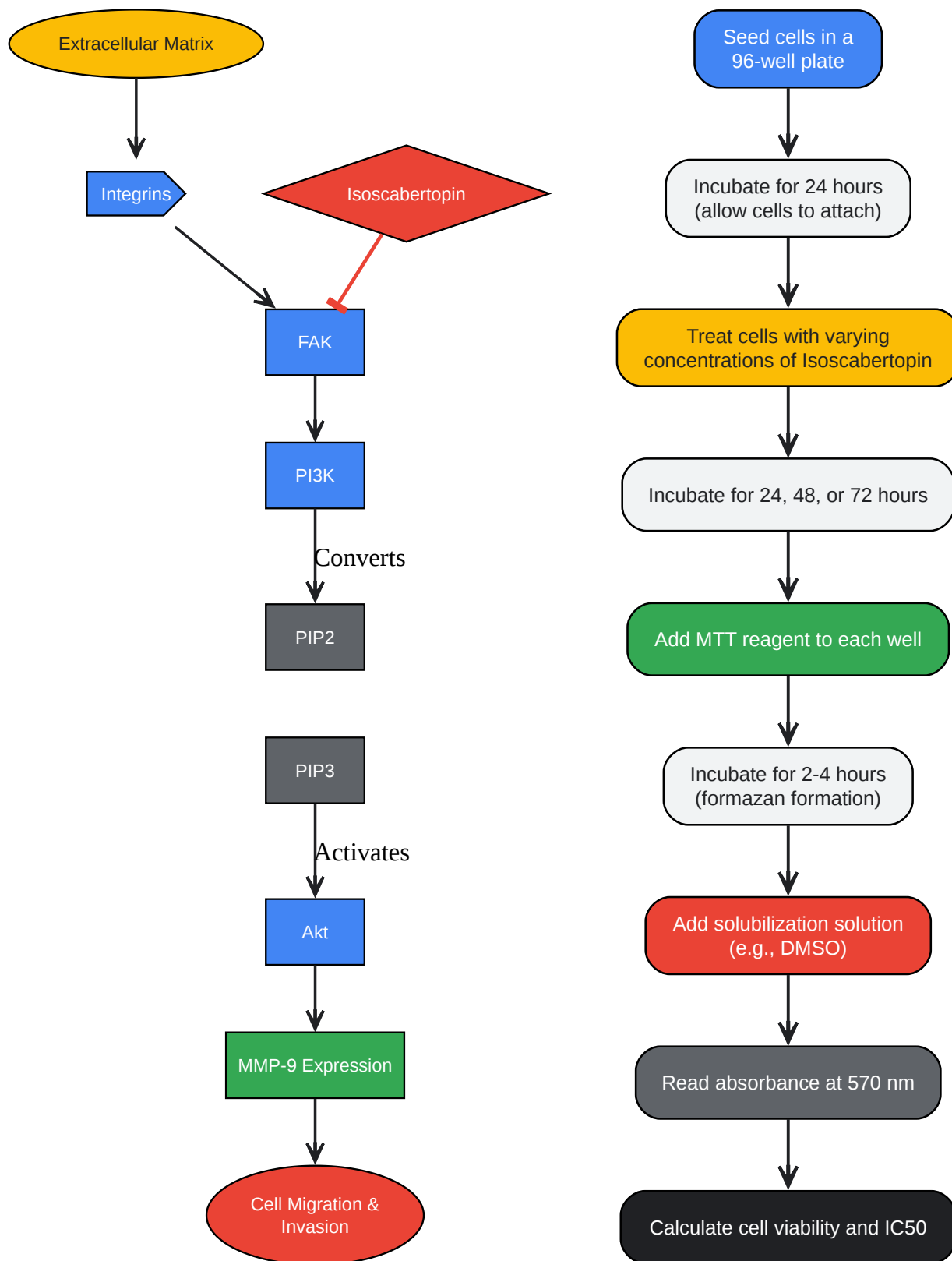

[Click to download full resolution via product page](#)

Need Custom Synthesis?

BenchChem offers custom synthesis for rare earth carbides and specific isotopic labeling.

Email: info@benchchem.com or [Request Quote Online](#).

References

- [1. Thieme E-Books & E-Journals - \[thieme-connect.com\]](#)
- [2. researchgate.net \[researchgate.net\]](#)
- [3. researchgate.net \[researchgate.net\]](#)
- [4. On the stability of sesquiterpene lactones in the officinal Arnica tincture of the German pharmacopoeia - PubMed \[pubmed.ncbi.nlm.nih.gov\]](#)
- [5. researchgate.net \[researchgate.net\]](#)
- To cite this document: BenchChem. [Isoscabertopin: Application Notes and Protocols for Experimental Use]. BenchChem, [2026]. [Online PDF]. Available at: [\[https://www.benchchem.com/product/b12966400/docs#isoscabertopin-application-notes-and-protocols-for-experimental-use\]](https://www.benchchem.com/product/b12966400/docs#isoscabertopin-application-notes-and-protocols-for-experimental-use)

Disclaimer & Data Validity:

The information provided in this document is for Research Use Only (RUO) and is strictly not intended for diagnostic or therapeutic procedures. While BenchChem strives to provide accurate protocols, we make no warranties, express or implied, regarding the fitness of this product for every specific experimental setup.

Technical Support: The protocols provided are for reference purposes. Unsure if this reagent suits your experiment?

Need Industrial/Bulk Grade? [Request Custom Synthesis Quote](#)

BenchChem

Our mission is to be the trusted global source of essential and advanced chemicals, empowering scientists and researchers to drive progress in science and industry.

Contact

Address: 3281 E Guasti Rd
Ontario, CA 91761, United States
Phone: (601) 213-4426
Email: info@benchchem.com

[Contact our Ph.D. Support Team for a compatibility check](#)