

Comparative Guide: Synthetic Architectures for 5-Oxo-5-Arylpentanoic Acids

Author: BenchChem Technical Support Team. **Date:** May 2026

Compound of Interest

Compound Name: 5-Oxo-5-(2,4,6-trimethylphenyl)pentanoic acid

CAS No.: 500892-07-9

Cat. No.: B1296070

[Get Quote](#)

Executive Summary: The Strategic Landscape

5-Oxo-5-arylpentanoic acids (also known as

-arylbutyric acids) are critical bifunctional intermediates in organic synthesis. They serve as the immediate precursors to

-tetralones via intramolecular cyclodehydration—a structural motif ubiquitous in antidepressants (e.g., Sertraline), histone deacetylase (HDAC) inhibitors, and liquid crystalline materials.

The synthesis of these scaffolds presents a classic "selectivity vs. scalability" dilemma. While the traditional Friedel-Crafts acylation remains the industrial workhorse, it suffers from poor regiocontrol on substituted arenes and significant environmental liability. Modern transition-metal-catalyzed routes offer precision but at a higher cost per kilogram.

This guide objectively compares three distinct synthetic methodologies, evaluating them on regioselectivity, atom economy, and operational complexity.

Route Analysis

Route A: Classical Friedel-Crafts Acylation (The Benchmark)

Mechanism: Electrophilic Aromatic Substitution (

) Primary Reagents: Arene, Glutaric Anhydride, Aluminum Chloride (

).

This is the standard route found in most undergraduate texts, but its operational reality is nuanced. The reaction proceeds via the opening of glutaric anhydride by an activated arene.

- The Protocol:
 - Activation:

(2.2 equiv) coordinates with glutaric anhydride, weakening the C-O bond to form a discrete acylium ion or a polarized complex.
 - Substitution: The arene attacks the electrophile.
 - Complexation: The resulting keto-acid forms a stable complex with aluminum species, necessitating the >2 stoichiometric equivalents of Lewis acid.
 - Hydrolysis: Ice/HCl quench breaks the aluminum complex to release the product.
- Critical Insight: For monosubstituted benzenes (e.g., toluene, anisole), para-selectivity is generally favored due to sterics, but significant ortho-isomer contamination (10–20%) is common. The "perisubstitution" effect in naphthalene derivatives can lead to mixtures of 1- and 2-aryl isomers depending on solvent polarity (Nitrobenzene vs. DCM).

Route B: Heterogeneous Catalysis (The Green Alternative)

Mechanism: Surface-Mediated Electrophilic Substitution Primary Reagents: Arene, Glutaric Anhydride, Zeolite H-Beta or H-ZSM-5.

To address the massive waste streams of

(which generates aluminum hydroxide sludge), solid acid catalysts are employed.

- The Protocol:
 - The reaction is run typically solvent-free or in high-boiling solvents (e.g., nitrobenzene) at elevated temperatures (120–160°C).
 - The pore size of the Zeolite (e.g., H-Beta) imposes shape selectivity, significantly enhancing para-selectivity by physically preventing the formation of the bulkier ortho-isomer transition state.
- Critical Insight: While "greener," this route often suffers from lower reaction rates and catalyst fouling (coking). It is most effective for electron-rich arenes (anisole, veratrole) but fails for deactivated systems.

Route C: Transition-Metal Catalyzed Desymmetrization (The Precision Tool)

Mechanism: Oxidative Addition / Transmetallation Primary Reagents: Arylboronic Acid, Glutaric Anhydride, Pd(II) or Rh(I) catalyst.

This modern approach avoids acidic conditions entirely, making it ideal for acid-sensitive substrates. It utilizes the "soft" nucleophilicity of boronic acids.

- The Protocol:
 - Oxidative Addition: The low-valent metal inserts into the C-O bond of the anhydride.
 - Transmetallation: The aryl group is transferred from the boronic acid to the metal center.
 - Reductive Elimination: The C-C bond is formed, releasing the keto-acid salt.
- Critical Insight: Based on the work of Gooßen et al., this method allows for the synthesis of keto-acids from complex aryl boronic acids that would not survive Friedel-Crafts conditions. It guarantees 100% regiocontrol relative to the arene ring (determined by the boronic acid structure).

Comparative Data Analysis

The following table summarizes the performance metrics of the three routes based on experimental data for the synthesis of 5-oxo-5-(4-methoxyphenyl)pentanoic acid (from anisole/4-methoxyphenylboronic acid).

Metric	Route A: Classical F-C	Route B: Zeolite H-Beta	Route C: Pd-Catalyzed
Yield	85-92%	60-75%	78-88%
Regioselectivity (p:o)	~90:10	>98:2	100:0 (Pre-defined)
Atom Economy	Moderate (Stoichiometric Al waste)	High (Catalytic water byproduct)	Moderate (Boronic acid waste)
Substrate Scope	Limited to Electron-Rich/Neutral	Strictly Electron-Rich	Broad (Tolerates esters, nitriles)
Cost	Low	Low (Reusable Catalyst)	High (Pd/Ligands)
E-Factor (Waste/Product)	High (>5)	Low (<1)	Moderate (~3)

Decision Logic & Mechanism Visualization

Figure 1: Synthetic Decision Matrix

Use this logic tree to select the optimal route for your specific substrate.

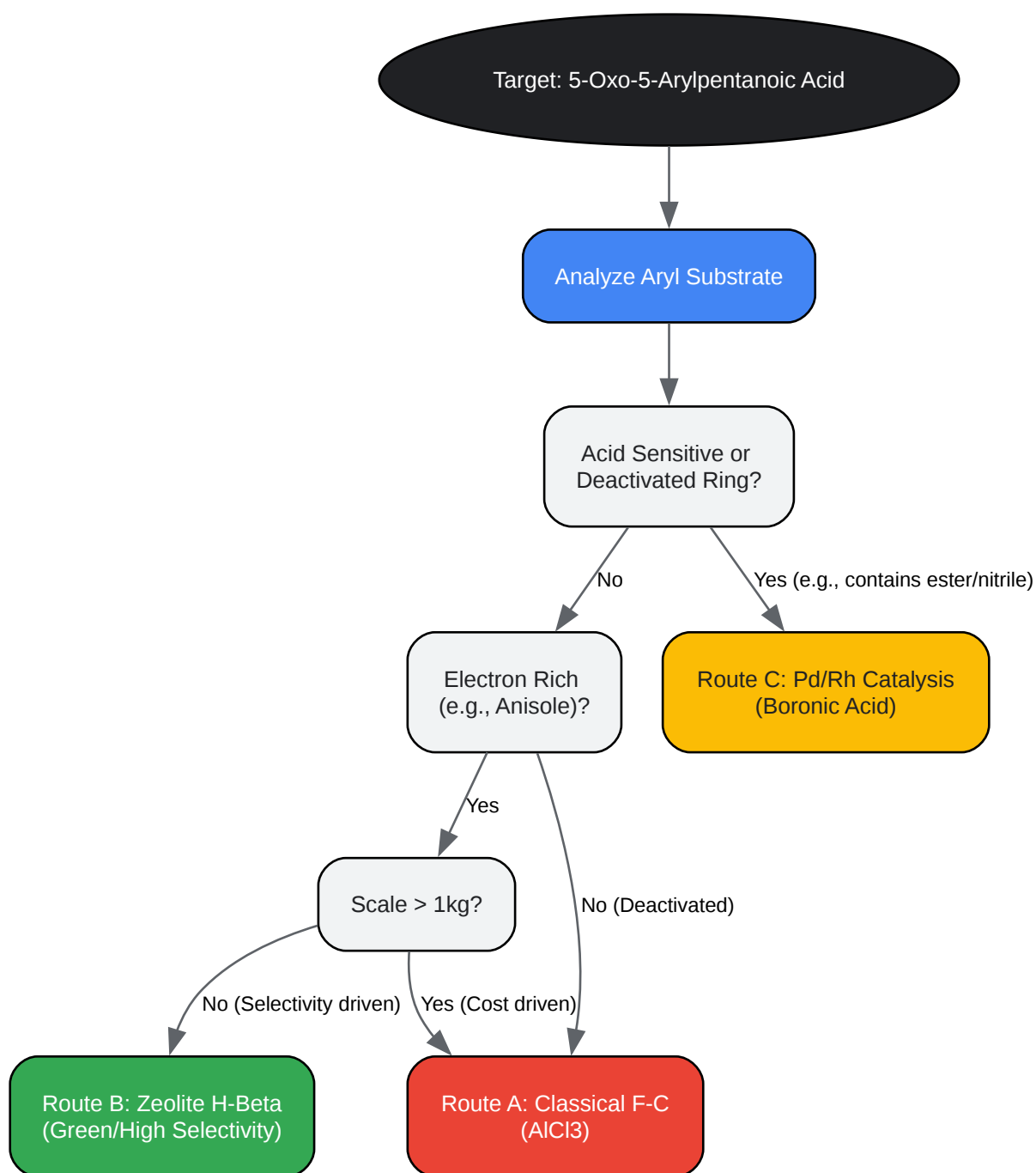

[Click to download full resolution via product page](#)

Caption: Decision tree for selecting the optimal synthetic route based on substrate electronics and scale.

Figure 2: Mechanistic Divergence

Comparison of the electrophilic activation (Route A) vs. oxidative insertion (Route C).

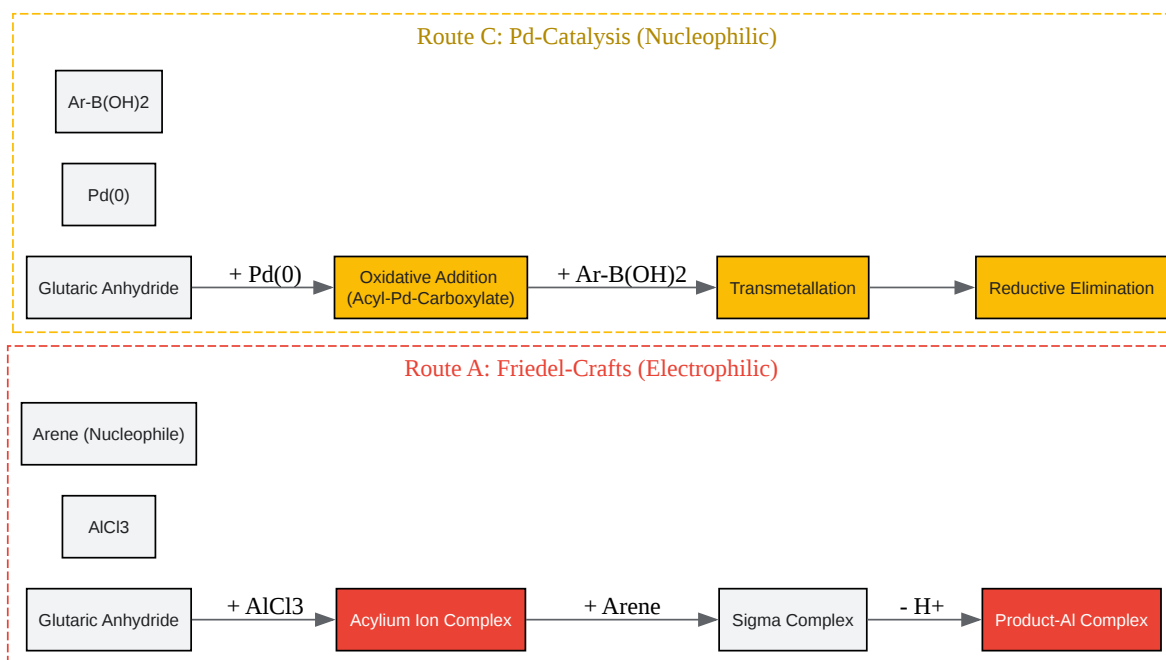

[Click to download full resolution via product page](#)

Caption: Mechanistic comparison showing the divergence between electrophilic activation (top) and oxidative addition (bottom).

Detailed Experimental Protocols

Protocol A: Classical Synthesis of 5-Oxo-5-phenylpentanoic Acid

Adapted from Vogel's Textbook of Practical Organic Chemistry.

- Setup: Equip a 500 mL three-necked flask with a reflux condenser, a sealed mechanical stirrer, and a dropping funnel. Attach a gas trap to neutralize HCl evolution.

- Charge: Add 30 g (0.26 mol) of glutaric anhydride and 100 mL of dry benzene (acting as both reactant and solvent).
- Addition: Cool the mixture to 0–5°C in an ice bath. Add 80 g (0.6 mol) of powdered anhydrous aluminum chloride in small portions over 45 minutes. Caution: Exothermic reaction.
- Reaction: Remove the ice bath and allow to warm to room temperature. Heat on a steam bath (approx. 60°C) for 1 hour until HCl evolution ceases.
- Quench: Pour the reaction mixture (now a viscous dark oil) onto 200 g of crushed ice mixed with 50 mL of conc. HCl.
- Workup: Steam distill to remove excess benzene. Cool the aqueous residue to precipitate the crude acid.
- Purification: Recrystallize from water or dilute ethanol.
 - Expected Yield: 80–85%.
 - Melting Point: 125–127°C.

Protocol C: Pd-Catalyzed Synthesis from Arylboronic Acids

Adapted from Goossen et al. (Concept applied to cyclic anhydrides).

- Setup: Flame-dry a Schlenk flask under argon.
- Charge: Add 4-tolylboronic acid (1.0 mmol), glutaric anhydride (1.2 mmol), (0.03 mmol), and (0.09 mmol).
- Solvent: Add THF (5 mL) and water (0.1 mL) or use a base like (1.5 equiv) depending on the specific catalytic variant.

- Reaction: Heat to 60°C for 16 hours.
- Workup: Acidify with 1M HCl, extract with ethyl acetate, and dry over .
- Purification: Flash chromatography (Hexane/EtOAc).
 - Note: This route avoids the formation of isomers entirely.[1]

Troubleshooting & Expert Tips

- Moisture Control (Route A):

is notoriously hygroscopic. If the reaction turns a light yellow instead of a deep red/brown, your catalyst may be deactivated. Always use fresh, yellow-green sublimate quality .

- The "Double Addition" Trap (Grignard Alternative): Researchers often attempt to react Aryl Grignards directly with glutaric anhydride. This frequently fails due to the ketone product being more reactive than the anhydride, leading to the tertiary alcohol. Solution: If you must use a Grignard, cool the reaction to -78°C and add the Grignard slowly to an excess of the anhydride (Inverse Addition).
- Cyclization to Tetralone: If the goal is the tetralone, do not isolate the highly pure acid from Route B/C if not necessary. The crude acid can often be cyclized directly using Polyphosphoric Acid (PPA) or followed by internal Friedel-Crafts.

References

- Vogel, A. I. Vogel's Textbook of Practical Organic Chemistry, 5th Ed. Longman Scientific & Technical, 1989. (Standard F-C Protocols).
- Gooßen, L. J., & Ghosh, K. "Palladium-Catalyzed Synthesis of Aryl Ketones from Boronic Acids and Carboxylic Acids Activated in situ by Pivalic Anhydride." [2] European Journal of Organic Chemistry, 2002(19), 3254–3267. [2] [Link](#)

- Corma, A., et al. "Acylation of anisole by carboxylic acids and acid anhydrides using zeolites as catalysts." *Applied Catalysis A: General*, 2001. (Green Chemistry/Zeolite Route).
- Gooßen, L. J., et al. "The Palladium-Catalyzed Cross-Coupling Reaction of Carboxylic Anhydrides with Arylboronic Acids: A DFT Study." *Journal of the American Chemical Society*, 2005, 127(31), 11102–11114. [3][4] [Link](#)
- BenchChem. "Application Notes and Protocols for the Synthesis of 8-(4-Heptyloxyphenyl)-8-oxooctanoic acid." (General F-C Protocol Reference). [Link](#)

Need Custom Synthesis?

BenchChem offers custom synthesis for rare earth carbides and specific isotopic labeling.

Email: info@benchchem.com or [Request Quote Online](#).

Sources

- 1. onlinelibrary.wiley.com [onlinelibrary.wiley.com]
- 2. Palladium-Catalyzed Synthesis of Aryl Ketones from Boronic Acids and Carboxylic Acids Activated in situ by Pivalic Anhydride [organic-chemistry.org]
- 3. The palladium-catalyzed cross-coupling reaction of carboxylic anhydrides with arylboronic acids: a DFT study - PubMed [pubmed.ncbi.nlm.nih.gov]
- 4. researchgate.net [researchgate.net]
- To cite this document: BenchChem. [Comparative Guide: Synthetic Architectures for 5-Oxo-5-Arylpentanoic Acids]. BenchChem, [2026]. [Online PDF]. Available at: [<https://www.benchchem.com/product/b1296070/docs#comparative-guide-synthetic-architectures-for-5-oxo-5-arylpentanoic-acids>]

Disclaimer & Data Validity:

The information provided in this document is for Research Use Only (RUO) and is strictly not intended for diagnostic or therapeutic procedures. While BenchChem strives to provide accurate protocols, we make no warranties, express or implied, regarding the fitness of this product for every specific experimental setup.

Technical Support: The protocols provided are for reference purposes. Unsure if this reagent suits your experiment?

Need Industrial/Bulk Grade? [Request Custom Synthesis Quote](#)

BenchChem

Our mission is to be the trusted global source of essential and advanced chemicals, empowering scientists and researchers to drive progress in science and industry.

Contact

Address: 3281 E Guasti Rd
Ontario, CA 91761, United States
Phone: (601) 213-4426
Email: info@benchchem.com

[Contact our Ph.D. Support Team for a compatibility check](#)