

Validating Kinase Inhibition in Cell-Based Assays: A Comparative Guide Featuring Dasatinib

Author: BenchChem Technical Support Team. **Date:** April 2026

Compound of Interest

Compound Name:	Terbuchlor
CAS No.:	4212-93-5
Cat. No.:	B1295756

[Get Quote](#)

In the realm of targeted cancer therapy, tyrosine kinase inhibitors (TKIs) have emerged as a cornerstone, revolutionizing treatment for various malignancies.[1][2] These small molecules are designed to block the action of tyrosine kinases, enzymes that play a crucial role in the signaling pathways governing cell growth, proliferation, and survival.[3][4] Dysregulation of these kinases is a common driver of cancer.[4] This guide provides a comparative analysis of the validation of kinase inhibition in cell-based assays, using the potent, orally bioavailable dual Src/Abl inhibitor, Dasatinib, as a primary example. We will compare its performance with other well-established TKIs, Bosutinib and Ponatinib, and provide detailed experimental protocols and visualizations to aid researchers in their drug development efforts.

Data Presentation: Comparative Kinase Inhibitory Activity

The half-maximal inhibitory concentration (IC₅₀) is a key metric for evaluating the potency of a kinase inhibitor. The table below summarizes the IC₅₀ values for Dasatinib, Bosutinib, and Ponatinib against several key kinases. Lower IC₅₀ values are indicative of greater potency.

Kinase Target	Dasatinib IC50 (nM)	Bosutinib IC50 (nM)	Ponatinib IC50 (nM)
BCR-ABL	0.9 - 9	~1	0.37 - 2
BCR-ABL (T315I Mutant)	>10,000	Inactive in vivo	2
c-SRC	0.5 - 16	1.2	~50 (various Src family)
c-KIT	-	>10,000	Potent inhibitor
PDGFR	-	>10,000	Potent inhibitor
VEGFR	-	-	Potent inhibitor
FGFR	-	-	Potent inhibitor

Note: IC50 values can vary based on the specific cell lines and assay conditions used. The data presented is a representative compilation from published literature.

Experimental Protocols

Western Blot for Analysis of Target Phosphorylation

A Western blot is a fundamental technique to directly assess the efficacy of a kinase inhibitor by measuring the phosphorylation state of its target protein or downstream substrates within the cell. A reduction in the phosphorylated form of the target protein upon treatment with the inhibitor confirms its intracellular activity.

Protocol:

- Cell Culture and Treatment:
 - Seed a suitable cell line (e.g., K562 for BCR-ABL or a cell line with activated Src signaling) in 6-well plates and allow them to adhere overnight.
 - Serum-starve the cells for 4-6 hours to reduce basal receptor phosphorylation levels.

- Pre-treat the cells with a range of concentrations of the kinase inhibitor (e.g., Dasatinib, Bosutinib, Ponatinib) for 1-2 hours. Include a vehicle control (e.g., DMSO).
- Stimulate the cells with an appropriate growth factor or activator (if necessary) for a short period (e.g., 10-15 minutes) to induce phosphorylation of the target kinase.
- Cell Lysis and Protein Quantification:
 - Wash the cells with ice-cold phosphate-buffered saline (PBS).
 - Lyse the cells in ice-cold RIPA buffer supplemented with protease and phosphatase inhibitors to preserve the phosphorylation state of proteins.
 - Centrifuge the lysates to pellet cell debris and collect the supernatant.
 - Determine the protein concentration of each lysate using a BCA or Bradford assay.
- SDS-PAGE and Protein Transfer:
 - Normalize the protein concentrations of all samples. Add Laemmli sample buffer and boil at 95-100°C for 5 minutes to denature the proteins.
 - Load equal amounts of protein (e.g., 20-30 µg) per lane onto an SDS-PAGE gel.
 - Separate the proteins by gel electrophoresis.
 - Transfer the separated proteins to a PVDF or nitrocellulose membrane.
- Immunoblotting and Detection:
 - Block the membrane with 5% Bovine Serum Albumin (BSA) in Tris-buffered saline with Tween 20 (TBST) to prevent non-specific antibody binding. Avoid using milk as a blocking agent as it contains phosphoproteins that can increase background noise.
 - Incubate the membrane with a primary antibody specific to the phosphorylated form of the target protein (e.g., anti-phospho-Src) overnight at 4°C.

- Wash the membrane with TBST and then incubate with an HRP-conjugated secondary antibody for 1 hour at room temperature.
- Wash the membrane again with TBST.
- Detect the signal using a chemiluminescent substrate and an imaging system.
- Stripping and Re-probing:
 - To normalize for protein loading, the membrane can be stripped of the antibodies and re-probed with an antibody against the total, non-phosphorylated form of the target protein and/or a loading control like β -actin.

Cell Viability Assay (MTT/MTS or Luminescence-Based)

Cell viability assays are used to determine the downstream effects of kinase inhibition, such as reduced proliferation or induced cell death (cytotoxicity).

Protocol:

- Cell Seeding:
 - Seed cells in a 96-well plate at an appropriate density (e.g., 5,000-10,000 cells/well) in 100 μ L of complete culture medium.
 - Incubate for 24 hours at 37°C in a 5% CO₂ incubator to allow for cell attachment.
- Compound Treatment:
 - Prepare serial dilutions of the kinase inhibitors in culture medium.
 - Remove the old medium from the wells and add 100 μ L of the diluted compound solutions. Include a vehicle control (DMSO) and a blank (medium only).
 - Incubate for a desired treatment duration (e.g., 48 or 72 hours).
- Measurement of Cell Viability:
 - For MTT Assay:

- Add 20 μ L of MTT solution to each well and incubate for 2-4 hours at 37°C.
- Add 100 μ L of a solubilization solution (e.g., DMSO or a specialized buffer) to each well to dissolve the formazan crystals.
- Read the absorbance at a specific wavelength (e.g., 570 nm) using a plate reader.
- For Luminescence-Based Assays (e.g., CellTiter-Glo®):
 - Add the reagent directly to the wells according to the manufacturer's instructions.
 - Mix and incubate for a short period.
 - Record the luminescence using a plate reader.
- Data Analysis:
 - Subtract the background absorbance/luminescence from all readings.
 - Calculate cell viability as a percentage of the vehicle control.
 - Plot a dose-response curve and determine the IC50 value using appropriate software (e.g., GraphPad Prism).

Mandatory Visualizations

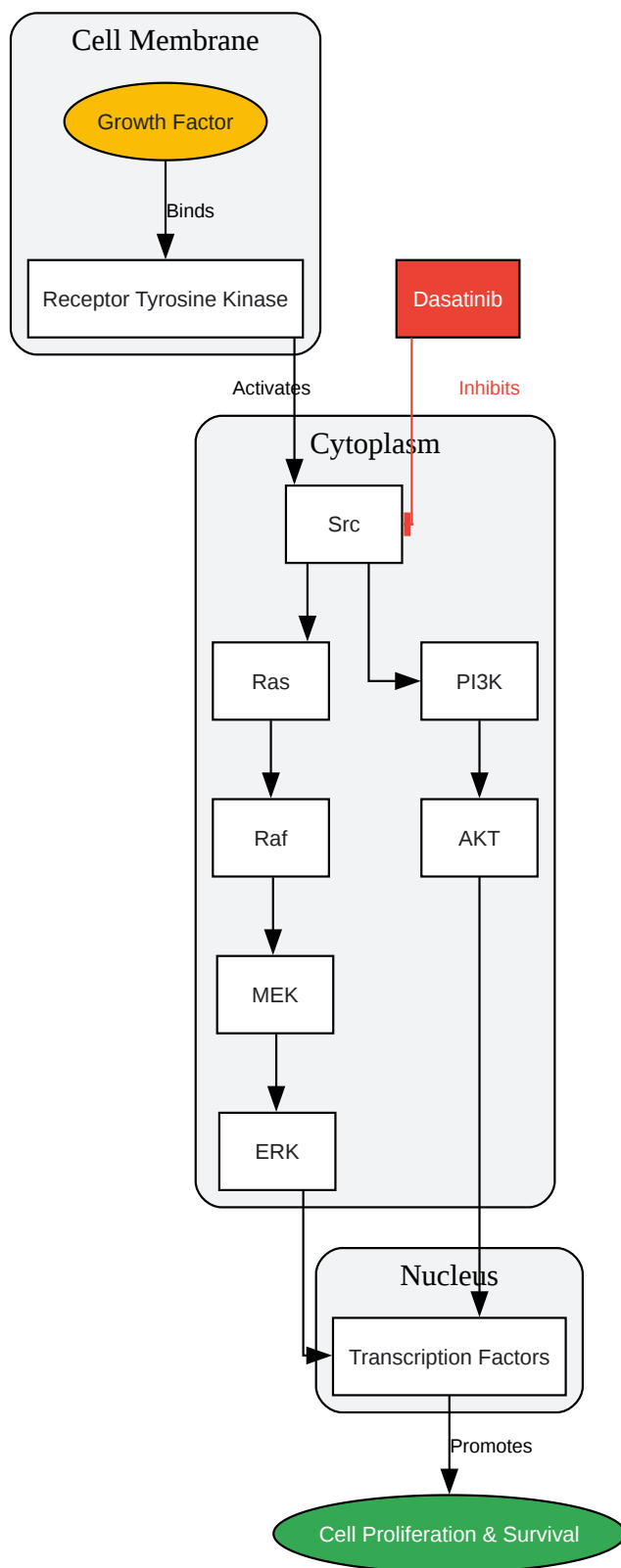

[Click to download full resolution via product page](#)

Caption: Simplified Src signaling pathway and the point of inhibition by Dasatinib.

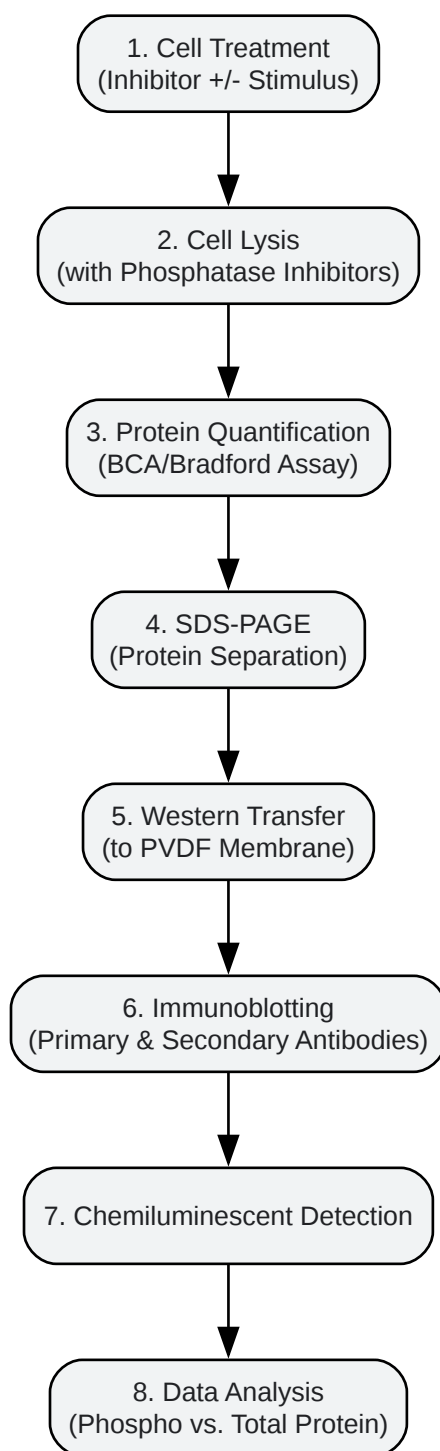

[Click to download full resolution via product page](#)

Caption: Experimental workflow for Western blot analysis of kinase inhibition.

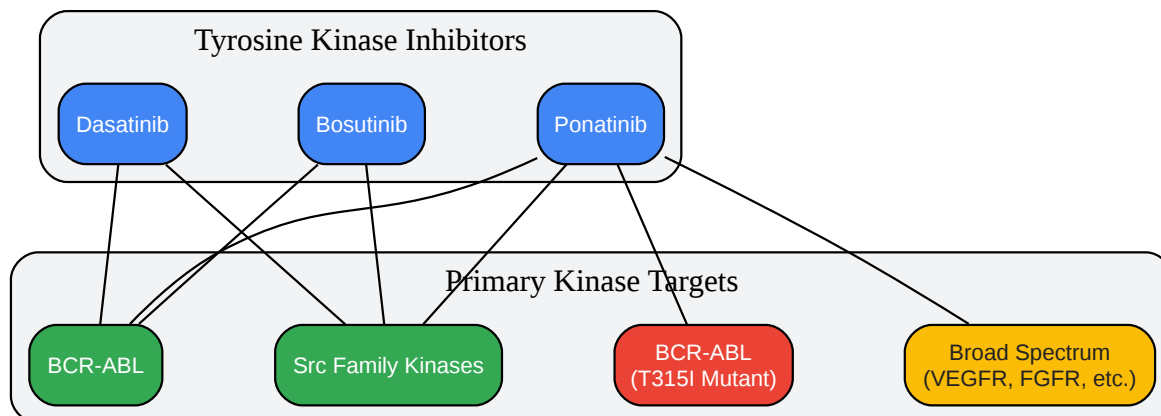

[Click to download full resolution via product page](#)

Caption: Logical relationships between selected TKIs and their primary targets.

Need Custom Synthesis?

BenchChem offers custom synthesis for rare earth carbides and specific isotopic labeling.

Email: info@benchchem.com or [Request Quote Online](#).

References

- 1. [benchchem.com](https://www.benchchem.com) [benchchem.com]
- 2. Tyrosine kinase inhibitor - Wikipedia [en.wikipedia.org]
- 3. cancerresearchuk.org [cancerresearchuk.org]
- 4. Tyrosine Kinase Inhibitors - StatPearls - NCBI Bookshelf [ncbi.nlm.nih.gov]
- To cite this document: BenchChem. [Validating Kinase Inhibition in Cell-Based Assays: A Comparative Guide Featuring Dasatinib]. BenchChem, [2026]. [Online PDF]. Available at: [<https://www.benchchem.com/product/b1295756/docs#validating-kinase-inhibition-in-cell-based-assays-a-comparative-guide-featuring-dasatinib>]

Disclaimer & Data Validity:

The information provided in this document is for Research Use Only (RUO) and is strictly not intended for diagnostic or therapeutic procedures. While BenchChem strives to provide accurate protocols, we make no warranties, express or implied, regarding the fitness of this product for every specific experimental setup.

Technical Support: The protocols provided are for reference purposes. Unsure if this reagent suits your experiment?

Need Industrial/Bulk Grade? [Request Custom Synthesis Quote](#)

BenchChem

Our mission is to be the trusted global source of essential and advanced chemicals, empowering scientists and researchers to drive progress in science and industry.

Contact

Address: 3281 E Guasti Rd
Ontario, CA 91761, United States
Phone: (601) 213-4426
Email: info@benchchem.com

[Contact our Ph.D. Support Team for a compatibility check](#)