

# Comparative Guide: MOM vs. SEM Protecting Groups for Phenols

**Author:** BenchChem Technical Support Team. **Date:** May 2026

## Compound of Interest

Compound Name: 2-(Methoxymethyl)phenol

CAS No.: 32391-38-1

Cat. No.: B1295808

[Get Quote](#)

## Strategic Overview: The Stability-Orthogonality Trade-off

In complex natural product synthesis and drug development, the choice between MOM and SEM for phenol protection is rarely arbitrary. It is a calculated decision balancing steric footprint, acid stability, and orthogonal deprotection strategies.

- **MOM (Methoxymethyl) Ether: The "Hard Hat."** It is sterically compact and electronically robust. It excels when the substrate must endure harsh organometallic conditions (e.g., organolithiums) or when steric crowding at the reaction site is a concern. However, its removal requires harsh acidic conditions that can jeopardize sensitive architecture.
- **SEM (2-(Trimethylsilyl)ethoxymethyl) Ether: The "Smart Switch."** It is bulkier but offers a unique "trapdoor"—susceptibility to fluoride ions. This allows for removal under neutral conditions, providing perfect orthogonality to acid-labile groups (like Boc, acetonides) and base-labile groups (esters).

## Critical Analysis of Properties

## 2.1 Electronic and Steric Profile

Both groups are acetal-based (

). The oxygen atoms render them excellent Directed Metalation Groups (DMGs) for ortho-lithiation.

- MOM: The methyl group is small ( 

-value negligible). It coordinates lithium tightly, making MOM-protected phenols one of the most powerful directors for ortho-lithiation (DoM).
- SEM: The trimethylsilylethyl tail adds significant steric bulk. While it still directs lithiation, the bulk can hinder approach of electrophiles at the ortho position compared to MOM. Crucially, the silicon atom exerts a 

-silicon effect, stabilizing positive charge build-up on the ether oxygen during acid-catalyzed hydrolysis, making SEM generally more acid-labile than MOM.

## 2.2 Safety and Handling (The "MOMCI Problem")

- MOMCI (Chloromethyl methyl ether): A potent carcinogen (OSHA regulated). Commercial sources often contain bis(chloromethyl) ether (BCME), a volatile and extreme carcinogen. Protocol Note: Many labs generate MOMCI in situ to mitigate risk, though this adds a step.
- SEMCI (2-(Trimethylsilyl)ethoxymethyl chloride): While still an alkylating agent and corrosive, it has lower volatility and a better safety profile than MOMCI. It is significantly more expensive, impacting scalability.

## Workflow 1: Protection Protocols

The formation of both ethers relies on the Williamson ether synthesis mechanism: deprotonation of the phenol followed by

attack on the highly reactive

-chloro ether.

### Mechanism of Formation

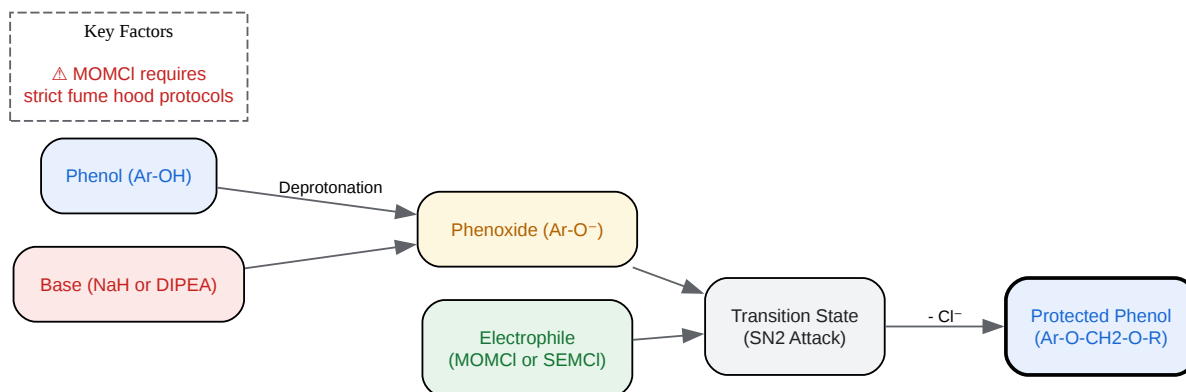

[Click to download full resolution via product page](#)

Figure 1: General mechanism for acetal-based phenol protection. The reaction is driven by the high electrophilicity of the chloromethyl species.

## Experimental Protocol: MOM Protection

- Reagents: Phenol (1.0 eq), NaH (1.5 eq, 60% dispersion), MOMCl (1.2 eq), DMF or THF (C to RT).
- Procedure:
  - Suspend NaH in dry THF/DMF under Argon at C.
  - Add phenol dropwise; stir 30 min to ensure phenoxide formation (evolution).
  - Add MOMCl dropwise (Caution: Carcinogen).
  - Warm to RT and stir 1–4 h. Quench with sat.

- Typical Yield: 85–95%.

## Experimental Protocol: SEM Protection

- Reagents: Phenol (1.0 eq), DIPEA (3.0 eq) or NaH (1.2 eq), SEMCl (1.5 eq), DCM or THF.
- Procedure:
  - Dissolve phenol in dry DCM under Argon.
  - Add DIPEA (Hünig's base) at  
  
C.
  - Add SEMCl dropwise. (Note: Fuming may occur).<sup>[1]</sup>
  - Stir at RT for 2–16 h. (Slower than MOM due to sterics).
- Typical Yield: 80–95%.

## Workflow 2: Stability & Ortho-Lithiation

This is where the divergence in utility is most pronounced.

### Directed Ortho Metalation (DoM)

Both groups coordinate Lithium, directing deprotonation to the ortho position.

- MOM: Superior director. The compact nature allows the alkyllithium aggregate to approach closely.
- SEM: Effective, but bulky. If the ortho position is crowded, SEM may inhibit lithiation or subsequent electrophile trapping.

### Stability Matrix

Condition	MOM Ether	SEM Ether	Note
Basic (NaOH, KOH)	Stable	Stable	Both excellent for base-catalyzed steps.
Nucleophiles (RLi, RMgX)	Stable	Stable	Both withstand Grignard/Lithium reagents.
Reduction (LiAlH <sub>4</sub> )	Stable	Stable	Inert to hydrides.
Oxidation (PCC, Jones)	Stable	Stable	Generally stable; benzylic oxidation possible.
Lewis Acids (TiCl <sub>4</sub> , BF <sub>3</sub> )	Labile	Very Labile	SEM cleaves faster due to Si-stabilization.

## Workflow 3: Deprotection Strategies

### The Fluoride Switch (SEM Specific)

The defining advantage of SEM is its cleavage by fluoride sources, driven by the formation of the strong Si–F bond (approx. 135 kcal/mol).

- Reagent: TBAF (Tetrabutylammonium fluoride) in THF or TAS-F.
- Mechanism: Fluoride attacks the Silicon atom; the ethyl linker fragments, releasing ethylene and formaldehyde, liberating the phenoxide.
- Protocol: Treat substrate (0.1 M in THF) with TBAF (2–3 eq) at RT or reflux.
- Selectivity: Cleaves SEM in the presence of MOM, Benzyl, and Methyl ethers. Not orthogonal to silyl ethers (TBS, TIPS).

### Acidic Cleavage (MOM & SEM)

Both are acetals and hydrolyze in acid.<sup>[2]</sup>

- MOM: Requires strong acid.<sup>[2]</sup>

- Conditions: 6M HCl/THF, or  
in DCM at  
C.
- Challenge: Phenolic MOM ethers are more stable than aliphatic MOM ethers due to the conjugation of the oxygen lone pair with the ring, making protonation less favorable.
- SEM: Cleaves under milder acidic conditions than MOM.
  - Conditions: TFA/DCM or  
/Nitromethane.

## Decision Matrix & Summary Data

### Comparative Performance Table

Feature	MOM (Methoxymethyl)	SEM (Trimethylsilylethoxymethyl)
Cost	Low (Reagents cheap)	High (SEMCI is expensive)
Safety	High Risk (Carcinogen)	Moderate Risk (Corrosive)
Steric Bulk	Low (Compact)	High (Bulky)
Acid Stability	Moderate	Low (More sensitive)
Fluoride Cleavage	No (Stable)	Yes (Primary method)
Ortho-Lithiation	Excellent	Good (Sterics may interfere)
Typical Yield	>90%	85–95%

### Selection Decision Tree

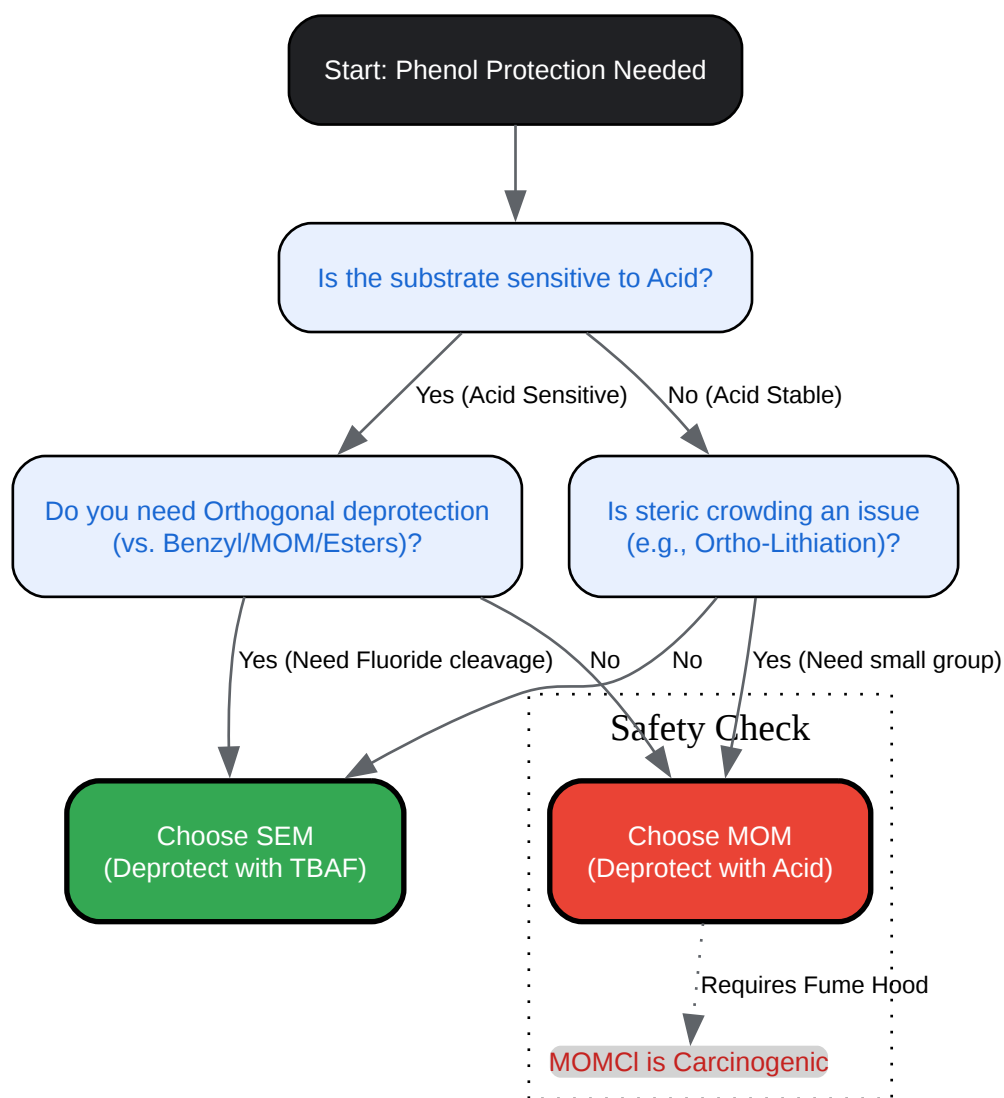

[Click to download full resolution via product page](#)

Figure 2: Strategic decision tree for selecting between MOM and SEM based on synthetic requirements.

## References

- Greene, T. W., & Wuts, P. G. M. (1999).<sup>[3]</sup> Protective Groups in Organic Synthesis (3rd ed.). Wiley-Interscience.<sup>[3]</sup> (The definitive source on stability charts).
- Lipshutz, B. H., & Pegram, J. J. (1980). "

-(Trimethylsilyl)ethoxymethyl chloride. A new reagent for the protection of the hydroxyl group." Tetrahedron Letters, 21(35), 3343-3346. (Original description of SEM utility).

- Snieckus, V. (1990). "Directed ortho metalation. Tertiary amide and O-carbamate directors in synthetic strategies for polysubstituted aromatics." Chemical Reviews, 90(6), 879–933. (Establishes MOM as a premier DoM director).
- Berliner, M. A., & Belecki, K. (2005).[3] "Simple, Rapid, and High-Yielding Synthesis of Haloalkyl Ethers." Journal of Organic Chemistry, 70(23), 9618–9621. (Discusses safety and synthesis of MOMCl/SEMCl).
- BenchChem. (2025). "Efficacy comparison of different protecting groups for phenols in synthesis." (Comparative yield data).

#### Need Custom Synthesis?

BenchChem offers custom synthesis for rare earth carbides and specific isotopic labeling.

Email: [info@benchchem.com](mailto:info@benchchem.com) or [Request Quote Online](#).

## Sources

- [1. reddit.com \[reddit.com\]](#)
- [2. Protecting groups in organic synthesis - protection and deprotection of alcoholic hydroxyl groups \(I\) \[en.highfine.com\]](#)
- [3. MOM Ethers \[organic-chemistry.org\]](#)
- To cite this document: BenchChem. [Comparative Guide: MOM vs. SEM Protecting Groups for Phenols]. BenchChem, [2026]. [Online PDF]. Available at: [\[https://www.benchchem.com/product/b1295808/docs#comparative-guide-mom-vs-sem-protecting-groups-for-phenols\]](https://www.benchchem.com/product/b1295808/docs#comparative-guide-mom-vs-sem-protecting-groups-for-phenols)

### Disclaimer & Data Validity:

The information provided in this document is for Research Use Only (RUO) and is strictly not intended for diagnostic or therapeutic procedures. While BenchChem strives to provide

accurate protocols, we make no warranties, express or implied, regarding the fitness of this product for every specific experimental setup.

**Technical Support:** The protocols provided are for reference purposes. Unsure if this reagent suits your experiment?

**Need Industrial/Bulk Grade?** [Request Custom Synthesis Quote](#)

## BenchChem

Our mission is to be the trusted global source of essential and advanced chemicals, empowering scientists and researchers to drive progress in science and industry.

### Contact

Address: 3281 E Guasti Rd

Ontario, CA 91761, United States

Phone: (601) 213-4426

Email: [info@benchchem.com](mailto:info@benchchem.com)

[Contact our Ph.D. Support Team for a compatibility check](#)