

Technical Support Center: Electrochemical Detection of Catecholamines

Author: BenchChem Technical Support Team. **Date:** April 2026

Compound of Interest

Compound Name: (S)-4-(1-Aminopropyl)benzene-1,2-diol
Cat. No.: B12945260

[Get Quote](#)

Current Status: Operational Support Tier: Level 3 (Senior Application Scientist) Topic: Troubleshooting Interferences in Catecholamine Detection (Dopamine, Norepinephrine, Epinephrine)

Introduction: The "Signal Overlap" Challenge

Welcome to the technical support hub. If you are detecting catecholamines—specifically dopamine (DA)—using electrochemical methods, you are likely facing the "Interference Triad": Ascorbic Acid (AA), Uric Acid (UA), and metabolites like DOPAC.

In biological matrices (brain tissue, serum, urine), AA concentration is often

—
times higher than DA. On standard carbon electrodes, their oxidation potentials overlap, merging into a single, indistinguishable peak. This guide provides the protocols and mechanistic insights to resolve these signals.

Visualizing the Problem

The following diagram illustrates the core failure mode when using unmodified electrodes.

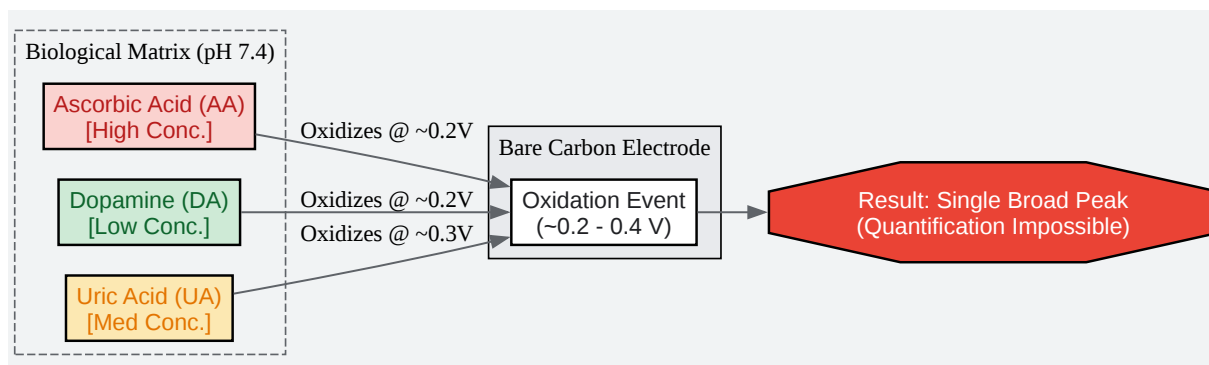

[Click to download full resolution via product page](#)

Figure 1: The "Voltammetric Masking" effect where high-concentration interferents obscure the target analyte on bare electrodes.

Module 1: Chemical Interferences (AA & UA)

Q: Why can't I resolve Dopamine from Ascorbic Acid on my Glassy Carbon Electrode (GCE)?

A: On a bare GCE, the electron transfer kinetics for Ascorbic Acid are sluggish (irreversible), causing its oxidation peak to shift positively (overpotential) until it sits directly on top of the Dopamine peak.

The Solution: You must accelerate the kinetics of one species or retard the other to create "Peak Separation" (

). A separation of

is required for simultaneous quantification using Differential Pulse Voltammetry (DPV).

Data Table: Oxidation Potentials & Separation Strategies

Potentials vs. Ag/AgCl at pH 7.4

Analyte	Bare GCE Potential ()	Nature at pH 7.4	Interference Mechanism	Mitigation Strategy
Ascorbic Acid (AA)	~-0.20 – 0.35 V	Anionic ()	High conc., overlaps DA	Electrostatic Repulsion (Nafion)
Dopamine (DA)	~-0.15 – 0.30 V	Cationic ()	Target Analyte	Electrocatalysis (Nanomaterials)
Uric Acid (UA)	~-0.30 – 0.45 V	Anionic ()	Adsorbs strongly (Fouling)	Surface Passivation

Module 2: Surface Engineering & Protocols

Q: How do I selectively detect Dopamine in the presence of excess Ascorbic Acid?

A: The industry-standard solution is Charge Discrimination. At physiological pH (7.4), Ascorbic Acid is negatively charged (anion), while Dopamine is positively charged (cation).[1] By coating your electrode with Nafion (a sulfonated tetrafluoroethylene based fluoropolymer-copolymer), you create a negatively charged barrier that repels AA but attracts DA.

Protocol: Nafion-Modified GCE Fabrication

Use this protocol to create a selective sensor for DA.

Reagents:

- Nafion solution (5 wt% in lower aliphatic alcohols/water mix).
- Ethanol (analytical grade).
- Alumina powder (0.05).

Step-by-Step Workflow:

- Electrode Polishing (Critical):
 - Polish the Glassy Carbon Electrode (GCE) with 0.05 alumina slurry on a microcloth pad for 2 minutes.
 - Sonicate in 1:1 Ethanol/Water for 3 minutes to remove alumina particles.
 - Validation: Run a Cyclic Voltammetry (CV) in
. Peak separation (
) should be
. If
, re-polish.
- Nafion Dilution:
 - Dilute the 5% Nafion stock solution to 0.5% - 1.0% using ethanol.
 - Note: Thick films (5%) increase resistance and slow down response time. Thin films (0.5%) offer the best balance of selectivity and sensitivity.
- Drop Casting:
 - Pipette 5
of the diluted Nafion solution directly onto the GCE surface.
 - Cover with a beaker to prevent dust but allow airflow.
 - Allow to dry at room temperature for 20–30 minutes.
- Activation:

- Soak the electrode in Phosphate Buffered Saline (PBS, pH 7.4) for 10 minutes before use to hydrate the membrane.

Visualizing the Nafion Mechanism

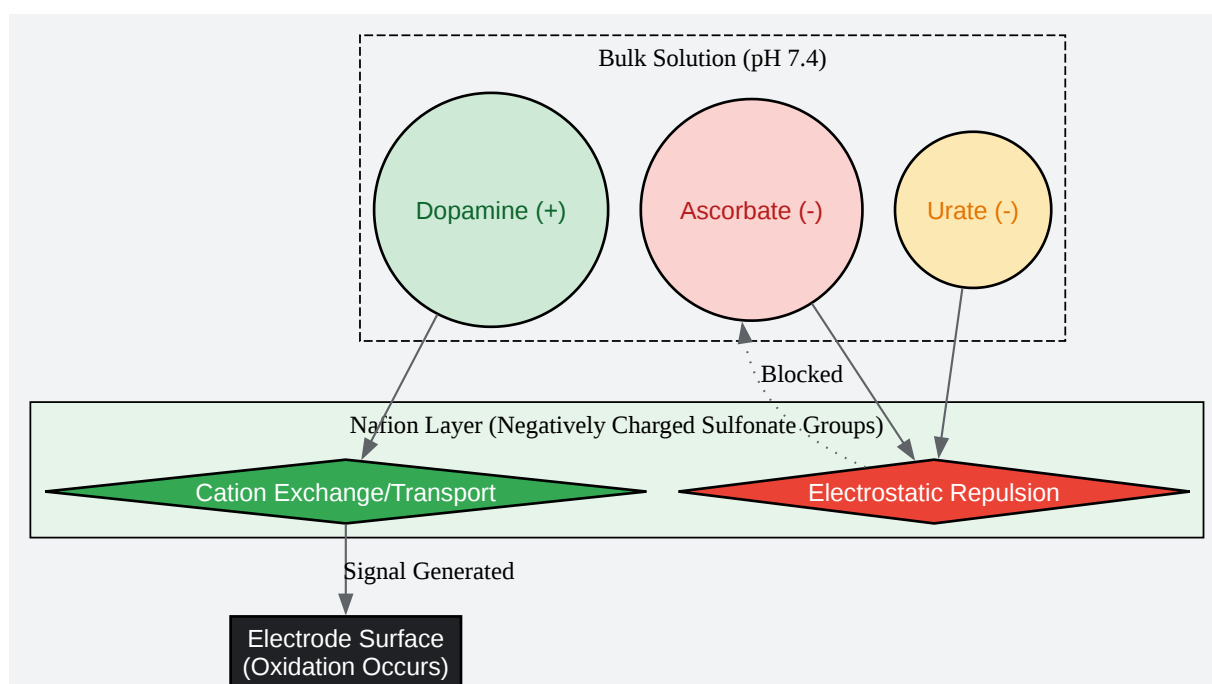

[Click to download full resolution via product page](#)

Figure 2: The charge-discrimination mechanism of Nafion coatings. Anionic interferences are repelled, while cationic dopamine is pre-concentrated.

Module 3: Metabolite Interference (DOPAC)

Q: How do I distinguish Dopamine from its metabolite DOPAC?

A: 3,4-Dihydroxyphenylacetic acid (DOPAC) is the primary metabolite of intracellular dopamine. Like AA, DOPAC is an anion at pH 7.4 (

), so Nafion coatings will also suppress DOPAC.

However, if you are using Fast Scan Cyclic Voltammetry (FSCV) (common in in vivo neuroscience), you distinguish them by Cyclic Voltammogram Shape, not just potential.

- Dopamine: Shows a distinct "duck-shaped" CV with clear oxidation and reduction peaks (reversible).
- DOPAC: Often shows an irreversible oxidation wave or a different peak separation profile depending on the scan rate.
- Troubleshooting: If you suspect DOPAC interference in FSCV, inspect the reduction peak. Dopamine has a strong reduction peak (closing the redox cycle); DOPAC's reduction peak is often absent or significantly shifted.

Module 4: Electrode Fouling & Drift

Q: My signal decays by 50% after 10 scans. Is my electrode broken?

A: It is likely fouled, not broken. The oxidation of dopamine produces dopamine-o-quinone.^[3] If this product is not reduced back quickly (or if concentrations are high), it undergoes an intramolecular cyclization to form leucochrome, eventually polymerizing into polydopamine—an insulating film that blocks the electrode surface.

Troubleshooting Guide: Anti-Fouling Maintenance

- Limit Concentration: Avoid testing with standard solutions unless necessary. High concentrations accelerate polymerization.
- Scan Rate: In FSCV, high scan rates () minimize the time the quinone stays near the electrode, reducing polymerization risk.
- Electrochemical Cleaning Protocol:

- If signal decays, immerse electrode in 0.5 M .
- Cycle potential from -0.2 V to +1.2 V at 100 mV/s for 20 cycles.
- Mechanism:[4][5][6] The generation of oxygen bubbles and surface oxide turnover strips the organic fouling layer.

References

- Simultaneous Electrochemical Sensing of Dopamine, Ascorbic Acid, and Uric Acid Using Nitrogen-Doped Graphene Sheet-Modified Glassy Carbon Electrode.MDPI. [[Link](#)]
- Electrochemical detection of Dopamine with Negligible Interference from Ascorbic and Uric acid by means of Reduced Graphene Oxide and metals-NPs based electrodes.ResearchGate/Analytica Chimica Acta. [[Link](#)]
- Electrochemical Detection of Dopamine Based on Functionalized Electrodes.MDPI. [[Link](#)]
- Fundamentals of Fast-Scan Cyclic Voltammetry for Dopamine Detection.NIH / PMC. [[Link](#)]
- Electrochemical Fouling of Dopamine and Recovery of Carbon Electrodes.Aalto University. [[Link](#)][5]

Need Custom Synthesis?

BenchChem offers custom synthesis for rare earth carbides and specific isotopic labeling.

Email: info@benchchem.com or [Request Quote Online](#).

Sources

- 1. [osti.gov](https://www.osti.gov) [[osti.gov](https://www.osti.gov)]
- 2. [mdpi.com](https://www.mdpi.com) [[mdpi.com](https://www.mdpi.com)]
- 3. PEMP lab [depts.washington.edu]

- [4. Nafion-coated cadmium pentacyanonitrosylferrate-modified glassy carbon electrode for detection of dopamine in biological samples - PMC \[pmc.ncbi.nlm.nih.gov\]](#)
- [5. researchgate.net \[researchgate.net\]](#)
- [6. researchgate.net \[researchgate.net\]](#)
- To cite this document: BenchChem. [Technical Support Center: Electrochemical Detection of Catecholamines]. BenchChem, [2026]. [Online PDF]. Available at: [\[https://www.benchchem.com/product/b12945260/docs#technical-support-center-electrochemical-detection-of-catecholamines\]](https://www.benchchem.com/product/b12945260/docs#technical-support-center-electrochemical-detection-of-catecholamines)

Disclaimer & Data Validity:

The information provided in this document is for Research Use Only (RUO) and is strictly not intended for diagnostic or therapeutic procedures. While BenchChem strives to provide accurate protocols, we make no warranties, express or implied, regarding the fitness of this product for every specific experimental setup.

Technical Support: The protocols provided are for reference purposes. Unsure if this reagent suits your experiment?

Need Industrial/Bulk Grade? [Request Custom Synthesis Quote](#)

BenchChem

Our mission is to be the trusted global source of essential and advanced chemicals, empowering scientists and researchers to drive progress in science and industry.

Contact

Address: 3281 E Guasti Rd
Ontario, CA 91761, United States
Phone: (601) 213-4426
Email: info@benchchem.com

[Contact our Ph.D. Support Team for a compatibility check](#)

