

# Spectral Properties of Oxidized Leucocrystal Violet: A Technical Guide

**Author:** BenchChem Technical Support Team. **Date:** April 2026

## Compound of Interest

Compound Name: *Leucocrystal violet-15n3*

Cat. No.: *B12939280*

[Get Quote](#)

## Abstract

This guide details the spectral transformation of Leucocrystal Violet (LCV) into its oxidized form, Crystal Violet (CV).<sup>[1][2]</sup> It is designed for researchers in forensics, radiation dosimetry, and analytical chemistry. The content focuses on the quantitative spectral characteristics (extinction coefficients), the physicochemical mechanisms driving these changes, and self-validating experimental protocols.

## Chemical Basis of the Spectral Transition

The utility of Leucocrystal Violet lies in its dramatic solvatochromic and electrochromic shift upon oxidation. LCV is a triphenylmethane derivative that is colorless in its reduced state due to the lack of a conjugated

-electron system across the central carbon.

## The Oxidation Mechanism

The transition from LCV to CV involves the removal of a hydride ion (or two electrons and a proton) from the central methane carbon. This results in the formation of a resonance-stabilized

carbocation. The positive charge is delocalized across the three dimethylamino-phenyl rings, creating a "propeller-like" conjugated system capable of absorbing visible light.

Key Chemical States:

- Leuco Form (LCV):

hybridized central carbon. Non-planar.

nm (UV only).

- Oxidized Form (CV):

hybridized central carbon. Planar propeller shape.

nm (Visible Violet).[3]

## Mechanism Diagram

The following diagram illustrates the pathway from LCV to CV, highlighting the catalytic role of Heme (in forensics) or Free Radicals (in dosimetry).

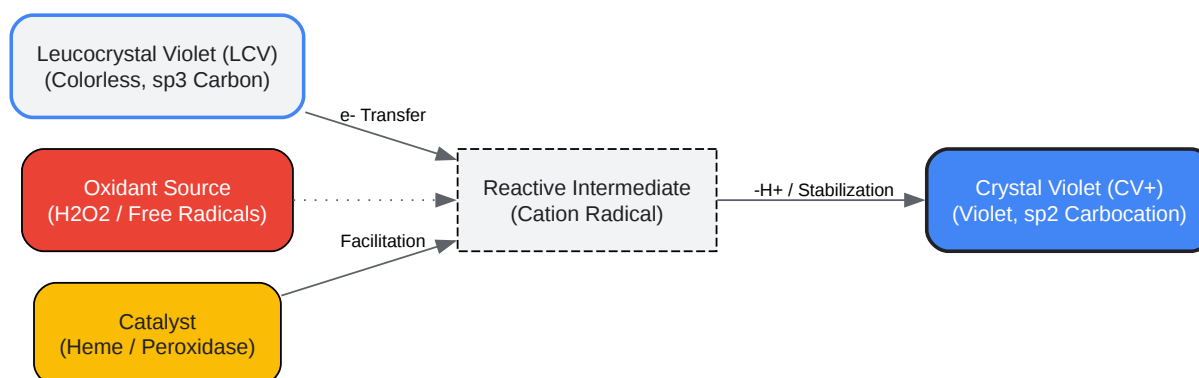

[Click to download full resolution via product page](#)

Figure 1: Mechanistic pathway of Leucocrystal Violet oxidation.[2][4] The transition restores conjugation, resulting in the chromophore formation.

## Spectral Properties

### Absorbance Characteristics

The oxidized form, Crystal Violet, exhibits a strong absorption band in the yellow-orange region, resulting in its complementary violet appearance.

Quantitative Spectral Data:

Parameter	Value	Conditions
Primary	590 nm	Aqueous solution, neutral pH
Secondary	~304 nm, ~250 nm	UV region transitions
Molar Extinction Coeff.[5] ( )	87,000	At 590 nm, Water [1]
Detection Limit (LOD)	~0.1 - 0.5	Dependent on path length/matrix

Solvatochromism: The

of Crystal Violet is sensitive to solvent polarity.

- Water: 590 nm[3][5][6][7]
- Ethanol: ~593 nm
- Glycerol: ~596 nm

### Fluorescence and Molecular Rotor Effects

Unlike many rigid fluorophores, Crystal Violet is a "molecular rotor." In low-viscosity solvents (like water), the excited state energy is dissipated non-radiatively through the rotation of the phenyl rings.

- In Water: Fluorescence is negligible (

).

- In Viscous Media (e.g., Glycerol, DNA binding): Rotation is restricted, forcing energy dissipation via fluorescence.
  - Excitation: ~540–550 nm
  - Emission: ~620–640 nm
  - Quantum Yield ( ): Increases to ~0.02 in glycerol; higher when intercalated in DNA [2].

## pH Dependence (Indicator Properties)

Crystal Violet is not stable across all pH ranges.

- pH < 1.0 (Strong Acid): Protonation of amine groups disrupts conjugation. Solution turns Yellow ( nm).[3][5]
- pH 1.0 – 2.0: Solution turns Green.
- pH > 2.0: Stable Violet form ( nm).

## Experimental Protocols

### Protocol Design Principles

To ensure data integrity, every experiment must include:

- Reagent Blank: Solvent + Oxidant (No LCV) to correct for background absorbance.
- Negative Control: LCV + Buffer (No Oxidant) to verify LCV stability.
- Positive Control: LCV + Known Oxidant (e.g., dilute

or Hemoglobin) to validate reagent activity.

## Standard Oxidation Workflow (Forensic/Analytical)

This protocol uses Heme-catalyzed oxidation, standard in forensic blood detection, but adaptable for enzymatic assays.

Reagents:

- Stock A: 10 mM LCV in Acetic Acid.
- Stock B: 3% Hydrogen Peroxide ( ).
- Buffer: Sodium Acetate (pH 5.0).
- Fixative (Optional): 5-Sulfosalicylic acid (precipitates proteins).

Workflow Diagram:

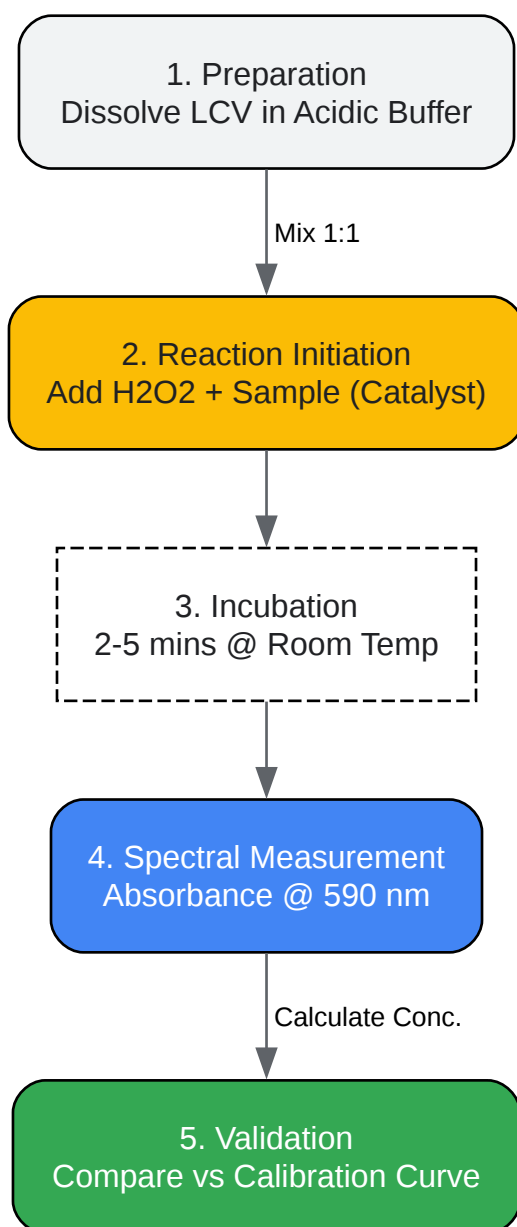

[Click to download full resolution via product page](#)

Figure 2: Step-by-step workflow for the spectrophotometric quantification of oxidized LCV.

## Dosimetry Formulation (Radiation Sensitive)

For radiation dosimetry, LCV is dissolved in a micelle gel to capture free radicals generated by ionizing radiation.

- Matrix: Gelatin + Triton X-100 (surfactant).

- Sensitizer: Trichloroacetic acid (TCA).

- Mechanism: Radiation

Water Radiolysis

/

LCV Oxidation.

- Readout: Optical CT scanning at 590 nm (peak) or 633 nm (HeNe laser).

## References

- Oregon Medical Laser Center (OMLC). (1998). Crystal Violet: Absorption and Fluorescence Spectra. PhotochemCAD. Retrieved from [[Link](#)]
- ResearchGate. (2015). Leuco-crystal-violet micelle gel dosimeters: Influence of recipe components. Retrieved from [[Link](#)]

### *Need Custom Synthesis?*

*BenchChem offers custom synthesis for rare earth carbides and specific isotopic labeling.*

*Email: [info@benchchem.com](mailto:info@benchchem.com) or [Request Quote Online](#).*

## Sources

- 1. [pdf.benchchem.com](https://pdf.benchchem.com) [[pdf.benchchem.com](https://pdf.benchchem.com)]
- 2. [researchgate.net](https://researchgate.net) [[researchgate.net](https://researchgate.net)]
- 3. [Crystal violet - Wikipedia](https://en.wikipedia.org) [[en.wikipedia.org](https://en.wikipedia.org)]
- 4. [researchgate.net](https://researchgate.net) [[researchgate.net](https://researchgate.net)]
- 5. [Crystal Violet - CAS-Number 548-62-9 - Order from Chemodex](https://chemodex.com) [[chemodex.com](https://chemodex.com)]
- 6. [Crystal Violet | CAS 548-62-9 | Chemodex | Biomol.com](https://biomol.com) [[biomol.com](https://biomol.com)]
- 7. [scribd.com](https://scribd.com) [[scribd.com](https://scribd.com)]
- To cite this document: BenchChem. [Spectral Properties of Oxidized Leucocrystal Violet: A Technical Guide]. BenchChem, [2026]. [Online PDF]. Available at:

[<https://www.benchchem.com/product/b12939280/docs#spectral-properties-of-oxidized-leucocrystal-violet-a-technical-guide>]

---

**Disclaimer & Data Validity:**

The information provided in this document is for Research Use Only (RUO) and is strictly not intended for diagnostic or therapeutic procedures. While BenchChem strives to provide accurate protocols, we make no warranties, express or implied, regarding the fitness of this product for every specific experimental setup.

**Technical Support:** The protocols provided are for reference purposes. Unsure if this reagent suits your experiment?

**Need Industrial/Bulk Grade?** [Request Custom Synthesis Quote](#)

## BenchChem

Our mission is to be the trusted global source of essential and advanced chemicals, empowering scientists and researchers to drive progress in science and industry.

### Contact

Address: 3281 E Guasti Rd  
Ontario, CA 91761, United States  
Phone: (601) 213-4426  
Email: [info@benchchem.com](mailto:info@benchchem.com)

[Contact our Ph.D. Support Team for a compatibility check](#)