

Technical Support Center: Catalyst Selection for Dihydropyran Synthesis

Author: BenchChem Technical Support Team. **Date:** April 2026

Compound of Interest

Compound Name: (3,6-Dihydro-2H-pyran-4-yl)methanamine

Cat. No.: B12938173

[Get Quote](#)

Welcome to the technical support center for dihydropyran synthesis. This guide is designed for researchers, scientists, and drug development professionals to navigate the complexities of catalyst selection for the hetero-Diels-Alder (HDA) reaction, a primary route to dihydropyran scaffolds.[1][2] Dihydropyrans are crucial structural motifs in a vast array of natural products and pharmaceutically active compounds.[2][3] Achieving high yield, selectivity, and efficiency in their synthesis is critically dependent on the judicious choice of a catalyst.

This resource provides in-depth, experience-driven answers to common challenges encountered in the lab, moving beyond simple protocols to explain the underlying chemical principles.

Frequently Asked Questions & Troubleshooting Guide

Section 1: Catalyst Selection & Initial Screening

Question 1: I am starting a new dihydropyran synthesis. What is the best general-purpose catalyst to begin with?

For a general starting point in dihydropyran synthesis via the hetero-Diels-Alder reaction, Ytterbium triflate ($\text{Yb}(\text{OTf})_3$) is an excellent choice.[4][5]

Causality & Rationale: Lanthanide triflates, like $\text{Yb}(\text{OTf})_3$, are highly effective Lewis acid catalysts that offer a unique combination of high activity, functional group tolerance, and remarkable water stability.[6][7] Unlike traditional Lewis acids such as AlCl_3 or TiCl_4 which decompose violently in the presence of moisture, lanthanide triflates can often be used in standard solvents without rigorous drying, and can even be recovered and reused.[4][7] They function by coordinating to the carbonyl oxygen of the aldehyde (the heterodienophile), which lowers its LUMO energy, thereby accelerating the [4+2] cycloaddition with the electron-rich diene.[8][9]

Question 2: My reaction is sluggish or gives a low yield. How do I choose a more potent catalyst?

If you are experiencing low reactivity, consider the electronic nature of your substrates and the "hardness" of the Lewis acid catalyst. A low yield can often be traced back to reactant quality or suboptimal reaction conditions.[10]

Troubleshooting Steps & Explanation:

- **Verify Reactant Quality:** Ensure your diene is fresh. For instance, cyclopentadiene readily dimerizes and must be "cracked" (via a retro-Diels-Alder reaction) immediately before use. [10] Likewise, ensure the aldehyde is pure and the solvents are anhydrous, as impurities can poison the catalyst.[10]
- **Increase Catalyst Strength:** If substrate quality is confirmed, a stronger Lewis acid may be necessary. The catalytic activity of metal-based Lewis acids often correlates with their electrophilicity. For example, catalysts like AlCl_3 and BF_3 are generally stronger than ZnCl_2 . [11] However, be aware that stronger Lewis acids can also promote undesired side reactions or substrate decomposition.
- **Consider Lanthanide Series:** Within the lanthanide triflates, Lewis acidity generally increases as the ionic radius decreases (from La to Lu). Therefore, switching from a larger lanthanide like $\text{La}(\text{OTf})_3$ to a smaller one like $\text{Sc}(\text{OTf})_3$ or $\text{Yb}(\text{OTf})_3$ can increase catalytic activity.

- **Heterogeneous Catalysts:** For reactions that are difficult to drive to completion, heterogeneous catalysts like zeolites or metal-organic frameworks (MOFs) can be effective, particularly when higher temperatures are required.^{[1][12]} Their high surface area and defined pore structures can enhance reaction rates, and they are easily removed by filtration.^{[12][13]}

Question 3: How can I achieve high stereoselectivity (enantioselectivity) in my synthesis?

Achieving high enantioselectivity requires the use of a chiral catalyst that creates a stereochemically-defined environment around the reactants.

Strategies & Catalyst Classes:

- **Chiral Lewis Acids (Metal-Based):** This is a well-established strategy. The most common approach involves complexing a Lewis acid with a chiral ligand. A prominent example is the use of copper(II) complexes with bis(oxazoline) ligands (often called "BOX" ligands).^{[3][14]} These C₂-symmetric complexes create a chiral pocket that forces the diene and dienophile to approach each other from a specific face, leading to high enantioselectivity.^{[14][15]}
- **Organocatalysis:** In recent years, organocatalysis has emerged as a powerful alternative to metal-based systems.^{[16][17]} Chiral secondary amines (e.g., derived from proline) or hydrogen-bond donors like squaramides can catalyze HDA reactions through different activation modes, such as the formation of a chiral iminium ion or through hydrogen bonding interactions.^{[18][19]} These methods can produce dihydropyrans with excellent enantioselectivities.^[16]

Section 2: Reaction Optimization & Troubleshooting

Question 4: I'm observing significant side product formation, including polymerization. What can I do?

Side product formation, especially polymerization of the diene or dienophile, is a common issue often caused by excessive catalyst activity or high temperatures.

Mitigation Strategies:

- Lower the Temperature: HDA reactions are often exothermic.[10] Running the reaction at a lower temperature (e.g., 0 °C or -78 °C) can significantly slow down competing polymerization pathways while still allowing the desired cycloaddition to proceed.
- Reduce Catalyst Loading: Use the lowest effective catalyst loading (mol%). Start with 5-10 mol% and titrate down. For highly active catalysts like lanthanide triflates, loadings as low as 0.2-1 mol% can be sufficient.[3]
- Switch to a Milder Catalyst: If a strong Lewis acid like AlCl_3 is causing problems, switch to a milder one like ZnCl_2 , InCl_3 , or a lanthanide triflate.[1][20]
- Consider a Heterogeneous Catalyst: Solid acid catalysts like zeolites or acidic resins (e.g., Amberlyst-15) can offer better selectivity.[1][13] The confined environment within the catalyst pores can disfavor the intermolecular reactions that lead to polymerization.

Question 5: My catalyst appears to be decomposing my starting materials or product. How can I prevent this?

This issue arises when your substrates contain functional groups that are sensitive to the Lewis acid.

Solutions:

- Protect Sensitive Groups: If your substrates have acid-sensitive functional groups (e.g., certain acetals, silyl ethers), consider using a protecting group strategy.
- Use Water-Tolerant Catalysts: For substrates with Lewis basic sites (e.g., amines, hydroxyls) that can irreversibly bind to and deactivate traditional Lewis acids, water-tolerant catalysts like lanthanide triflates are ideal.[6][7] Their ability to function in the presence of Lewis bases makes them more robust.
- Employ Organocatalysis: Organocatalysts often operate under much milder, near-neutral conditions, making them highly compatible with a wide range of sensitive functional groups. [18][16]

Question 6: How do I efficiently remove the catalyst after the reaction is complete?

Catalyst removal is a critical step for product purity, especially in pharmaceutical applications. The method depends on the type of catalyst used.

- Homogeneous Lewis Acids (e.g., $\text{Yb}(\text{OTf})_3$, $\text{Cu}(\text{OTf})_2$):
 - Aqueous Workup: For water-tolerant catalysts, a simple aqueous wash during workup can remove a significant portion of the metal salt.
 - Adsorption: Passing a solution of the crude product through a short plug of silica gel, neutral alumina, or an ion-exchange resin is a highly effective method for scavenging residual metal catalysts.[\[21\]](#)
- Heterogeneous Catalysts (e.g., Zeolites, MOFs, Resins):
 - Filtration: The primary advantage of these catalysts is the ease of removal. Simply filter the reaction mixture to separate the solid catalyst from the product solution.[\[12\]](#)[\[22\]](#) The catalyst can often be washed and reused.[\[12\]](#)
- Immobilized Catalysts: A modern approach involves using catalysts impregnated into 3D-printed devices or other solid supports.[\[23\]](#) Upon reaction completion, the device is simply removed from the mixture, eliminating the need for a complex workup.[\[23\]](#)

Data & Protocols

Table 1: Comparison of Common Catalysts for Dihydropyran Synthesis

Catalyst	Typical Loading (mol%)	Solvent(s)	Temperature (°C)	Key Advantages	Potential Issues
Yb(OTf) ₃	1 - 10	CH ₂ Cl ₂ , MeCN, H ₂ O	-20 to RT	High activity, water-tolerant, recyclable.[4] [6]	Can be expensive.
Cu(OTf) ₂ -BOX	0.5 - 10	CH ₂ Cl ₂ , THF	-78 to 0	Excellent for asymmetric synthesis.[3] [14]	Requires chiral ligand synthesis.
Amberlyst-15	10 - 20 wt%	Toluene, CH ₂ Cl ₂	RT to 60	Heterogeneous, easily removed, reusable.	Lower activity than homogeneous catalysts.
Proline	10 - 30	DMSO, CH ₂ Cl ₂	RT	Organocatalytic, avoids metals, good for sensitive substrates.	Higher catalyst loading often needed.
Ta-MOF	~4 mg	H ₂ O/EtOH	RT	Highly recyclable, efficient under mild conditions. [12]	Requires synthesis of the MOF material.

General Experimental Protocol: Yb(OTf)₃-Catalyzed Hetero-Diels-Alder Reaction

This protocol provides a general method for the synthesis of a dihydropyran from an α,β -unsaturated aldehyde and an enol ether.

Materials:

- α,β -Unsaturated aldehyde (1.0 eq)
- Enol ether (1.2 - 2.0 eq)
- Ytterbium(III) triflate ($\text{Yb}(\text{OTf})_3$) (0.05 eq, 5 mol%)
- Anhydrous Dichloromethane (CH_2Cl_2)

Procedure:

- **Setup:** To a flame-dried round-bottom flask under a nitrogen or argon atmosphere, add $\text{Yb}(\text{OTf})_3$ (5 mol%).
- **Solvent Addition:** Add anhydrous dichloromethane via syringe to achieve a final aldehyde concentration of approximately 0.2 M. Stir the suspension.
- **Aldehyde Addition:** Add the α,β -unsaturated aldehyde (1.0 eq) to the flask. Stir for 5 minutes.
- **Dienophile Addition:** Cool the reaction mixture to the desired temperature (e.g., 0 °C). Add the enol ether (1.2 eq) dropwise over 5 minutes.
- **Reaction Monitoring:** Allow the reaction to stir at the set temperature. Monitor the reaction progress by Thin Layer Chromatography (TLC) or LC-MS until the aldehyde is consumed.
- **Quenching:** Upon completion, quench the reaction by adding a saturated aqueous solution of sodium bicarbonate (NaHCO_3).
- **Workup:** Transfer the mixture to a separatory funnel. Extract the aqueous layer with dichloromethane (3x). Combine the organic layers, wash with brine, dry over anhydrous sodium sulfate (Na_2SO_4), filter, and concentrate under reduced pressure.
- **Purification:** Purify the crude product by flash column chromatography on silica gel to afford the desired dihydropyran.

Visualizations: Mechanisms & Workflows

Diagram 1: General Lewis Acid Catalysis Mechanism

This diagram illustrates the fundamental activation step in a Lewis acid-catalyzed hetero-Diels-Alder reaction. The Lewis acid (LA) coordinates to the carbonyl oxygen of the aldehyde, increasing its electrophilicity and accelerating the cycloaddition.

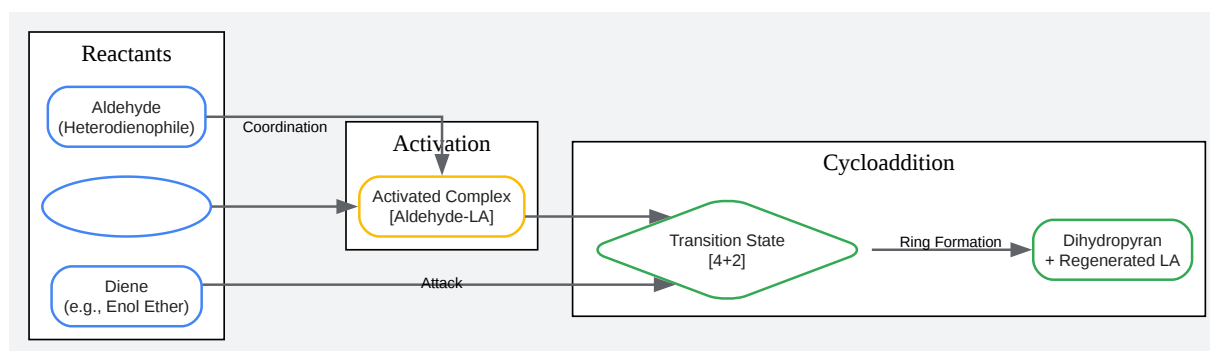

[Click to download full resolution via product page](#)

Caption: Lewis Acid (LA) activation pathway for the hetero-Diels-Alder reaction.

Diagram 2: Catalyst Selection Workflow

This workflow provides a decision-making tree for selecting an appropriate catalyst based on the experimental goals and substrate properties.

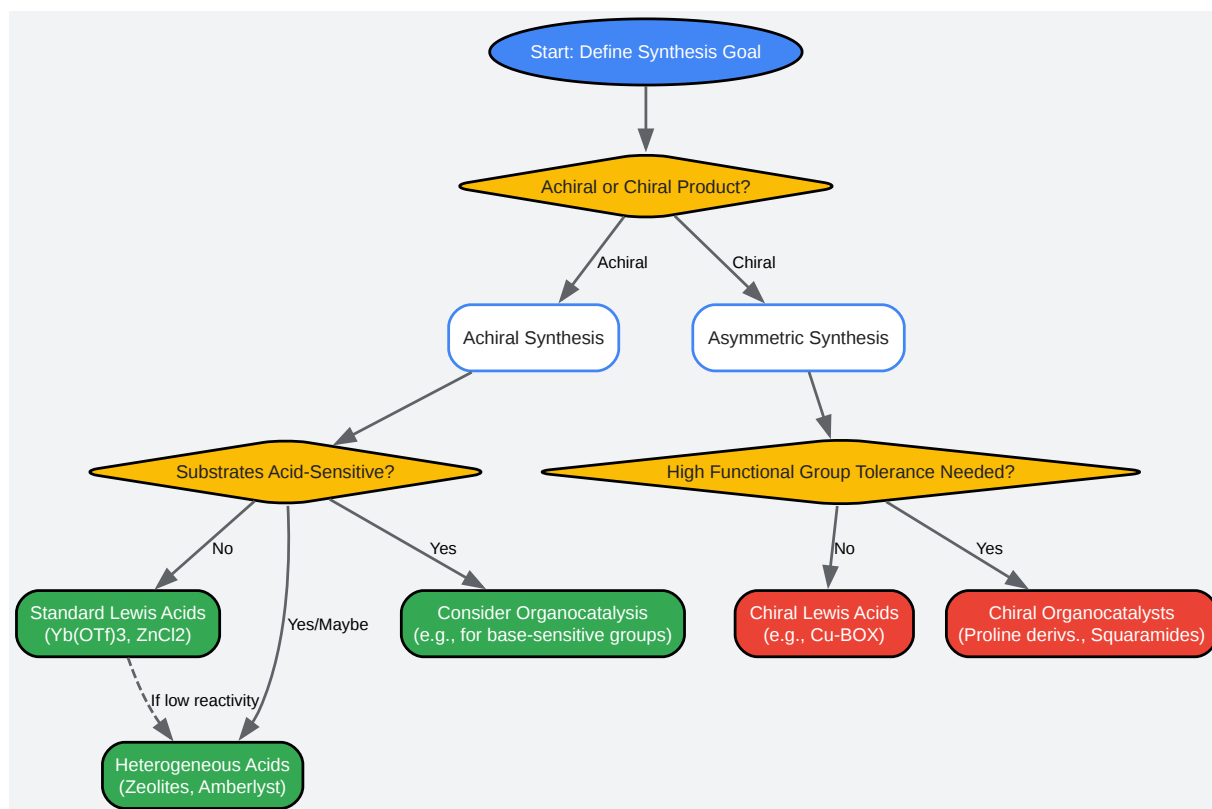

[Click to download full resolution via product page](#)

Caption: Decision tree for selecting a catalyst for dihydropyran synthesis.

Diagram 3: Troubleshooting Guide for Low Yield

This logic tree helps diagnose and solve common causes of low reaction yield.

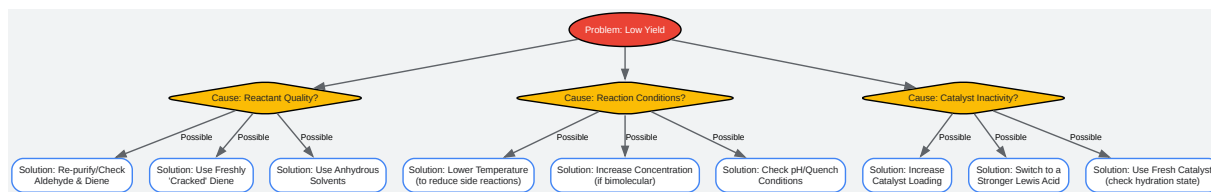

[Click to download full resolution via product page](#)

Need Custom Synthesis?

BenchChem offers custom synthesis for rare earth carbides and specific isotopic labeling.

Email: info@benchchem.com or [Request Quote Online](#).

Sources

- [1. benchchem.com](https://www.benchchem.com) [[benchchem.com](https://www.benchchem.com)]
- [2. pdf.benchchem.com](https://pdf.benchchem.com) [pdf.benchchem.com]
- [3. pubs.acs.org](https://pubs.acs.org) [pubs.acs.org]
- [4. Lanthanide Triflate Catalyzed Biginelli Reaction. One-Pot Synthesis of Dihydropyrimidinones under Solvent-Free Conditions](https://organic-chemistry.org) [organic-chemistry.org]
- [5. Lanthanide triflate catalyzed Biginelli reaction. one-pot synthesis of dihydropyrimidinones under solvent-free conditions](https://pubmed.ncbi.nlm.nih.gov) - PubMed [pubmed.ncbi.nlm.nih.gov]
- [6. Lanthanide trifluoromethanesulfonates](https://en.wikipedia.org) - Wikipedia [en.wikipedia.org]
- [7. Lanthanide_triflates](https://chemeuropa.com) [chemeuropa.com]
- [8. chemistry.illinois.edu](https://chemistry.illinois.edu) [chemistry.illinois.edu]
- [9. chem.libretexts.org](https://chem.libretexts.org) [chem.libretexts.org]
- [10. pdf.benchchem.com](https://pdf.benchchem.com) [pdf.benchchem.com]

- [11. How Lewis Acids Catalyze Diels–Alder Reactions - PMC \[pmc.ncbi.nlm.nih.gov\]](#)
- [12. Frontiers | Synthesis and characterization of new 1,4-dihydropyran derivatives by novel Ta-MOF nanostructures as reusable nanocatalyst with antimicrobial activity \[frontiersin.org\]](#)
- [13. Heterogeneous Diels–Alder catalysis for biomass-derived aromatic compounds - Green Chemistry \(RSC Publishing\) \[pubs.rsc.org\]](#)
- [14. Enantioselective Synthesis of Dihydropyrans. Catalysis of Hetero Diels-Alder Reactions by Bis\(oxazoline\) Copper\(II\) Complexes \[organic-chemistry.org\]](#)
- [15. quora.com \[quora.com\]](#)
- [16. pure.au.dk \[pure.au.dk\]](#)
- [17. Asymmetric organocatalytic methods for the synthesis of tetrahydropyrans and their application in total synthesis - Chemical Society Reviews \(RSC Publishing\) \[pubs.rsc.org\]](#)
- [18. Asymmetric Synthesis of Functionalized Dihydro- and Tetrahydropyrans via an Organocatalytic Domino Michael–Hemiacetalization Reaction - PMC \[pmc.ncbi.nlm.nih.gov\]](#)
- [19. mdpi.com \[mdpi.com\]](#)
- [20. ias.ac.in \[ias.ac.in\]](#)
- [21. Catalyst Removal - Matyjaszewski Polymer Group - Carnegie Mellon University \[cmu.edu\]](#)
- [22. researchgate.net \[researchgate.net\]](#)
- [23. pubs.acs.org \[pubs.acs.org\]](#)
- To cite this document: BenchChem. [Technical Support Center: Catalyst Selection for Dihydropyran Synthesis]. BenchChem, [2026]. [Online PDF]. Available at: [\[https://www.benchchem.com/product/b12938173/docs#technical-support-center-catalyst-selection-for-dihydropyran-synthesis\]](https://www.benchchem.com/product/b12938173/docs#technical-support-center-catalyst-selection-for-dihydropyran-synthesis)

Disclaimer & Data Validity:

The information provided in this document is for Research Use Only (RUO) and is strictly not intended for diagnostic or therapeutic procedures. While BenchChem strives to provide accurate protocols, we make no warranties, express or implied, regarding the fitness of this product for every specific experimental setup.

Technical Support: The protocols provided are for reference purposes. Unsure if this reagent suits your experiment?

Need Industrial/Bulk Grade? [Request Custom Synthesis Quote](#)

BenchChem

Our mission is to be the trusted global source of essential and advanced chemicals, empowering scientists and researchers to drive progress in science and industry.

Contact

Address: 3281 E Guasti Rd
Ontario, CA 91761, United States
Phone: (601) 213-4426
Email: info@benchchem.com

[Contact our Ph.D. Support Team for a compatibility check](#)