

Synthesis and Properties of 9-Vinylanthracene-Based Copolymers: Application Notes and Protocols

Author: BenchChem Technical Support Team. **Date:** December 2025

Compound of Interest

Compound Name: 9-Vinylanthracene

Cat. No.: B1293765

[Get Quote](#)

For Researchers, Scientists, and Drug Development Professionals

This document provides detailed application notes and protocols for the synthesis and characterization of **9-vinylanthracene**-based copolymers. These materials are of significant interest due to their unique photophysical and electronic properties, lending them to applications in organic electronics, sensing, and bio-imaging.

Introduction

9-Vinylanthracene (9-VA) is a fluorescent monomer that can be copolymerized with various vinyl monomers to produce polymers with tailored properties. The anthracene moiety imparts desirable characteristics such as high fluorescence quantum yields and the ability to undergo [4+4] cycloaddition reactions, which can be utilized for cross-linking or sensing applications. However, the reactivity of 9-VA is lower than that of common monomers like styrene, which presents challenges in achieving high incorporation rates in copolymers.^[1] This document outlines synthetic strategies to address these challenges and provides protocols for characterization of the resulting copolymers.

Synthesis of 9-Vinylanthracene-Based Copolymers

The synthesis of **9-vinylanthracene**-based copolymers can be achieved through several polymerization techniques, including free-radical polymerization, and controlled radical

polymerization methods such as Atom Transfer Radical Polymerization (ATRP) and Reversible Addition-Fragmentation chain-Transfer (RAFT) polymerization.

Free-Radical Polymerization

Free-radical polymerization is a common and straightforward method for synthesizing 9-VA copolymers. However, it offers limited control over molecular weight and polydispersity. Due to the lower reactivity of 9-VA compared to monomers like styrene, the incorporation of 9-VA into the copolymer can be significantly lower than the feed ratio.^[1]

Experimental Protocol: Free-Radical Copolymerization of **9-Vinylanthracene** and Styrene

This protocol describes the synthesis of a random copolymer of **9-vinylanthracene** and styrene.

Materials:

- **9-Vinylanthracene** (9-VA)
- Styrene (St)
- 2,2'-Azobis(2-methylpropionitrile) (AIBN)
- Anhydrous Toluene
- Methanol

Procedure:

- In a Schlenk flask, dissolve the desired molar ratio of **9-vinylanthracene** and styrene in anhydrous toluene.
- Add AIBN (typically 1 mol% relative to the total monomer concentration).
- Degas the solution by three freeze-pump-thaw cycles to remove dissolved oxygen.
- Backfill the flask with an inert gas (e.g., nitrogen or argon) and place it in a preheated oil bath at 70-80 °C.

- Allow the polymerization to proceed for a specified time (e.g., 24 hours).
- Cool the reaction to room temperature and precipitate the polymer by pouring the solution into a large excess of cold methanol.
- Collect the polymer by filtration, wash with methanol, and dry under vacuum at 60 °C to a constant weight.

Characterization: The resulting copolymer can be characterized by:

- ¹H NMR Spectroscopy: To determine the copolymer composition.
- Gel Permeation Chromatography (GPC): To determine the number-average molecular weight (Mn), weight-average molecular weight (Mw), and polydispersity index (PDI).
- Differential Scanning Calorimetry (DSC): To determine the glass transition temperature (Tg).
- Thermogravimetric Analysis (TGA): To assess the thermal stability.
- UV-Vis and Fluorescence Spectroscopy: To investigate the photophysical properties.

Atom Transfer Radical Polymerization (ATRP)

ATRP is a controlled radical polymerization technique that allows for the synthesis of polymers with well-defined molecular weights and low polydispersity. While specific protocols for the direct ATRP of **9-vinylanthracene** are not widely reported, general methods for ATRP of methacrylates can be adapted, and anthracene-containing initiators can be used to synthesize end-functionalized polymers.

Conceptual Protocol: ATRP of 9-Anthracenylmethyl Methacrylate (AMMA) and Methyl Methacrylate (MMA)

This hypothetical protocol is based on established ATRP procedures for methacrylate monomers.

Materials:

- 9-Anthracenylmethyl methacrylate (AMMA)

- Methyl methacrylate (MMA)
- Ethyl α -bromoisobutyrate (EBiB) (initiator)
- Copper(I) bromide (CuBr) (catalyst)
- N,N,N',N'',N''-Pentamethyldiethylenetriamine (PMDETA) (ligand)
- Anisole (solvent)
- Methanol (non-solvent)

Procedure:

- To a Schlenk flask, add CuBr. Seal the flask, and evacuate and backfill with nitrogen three times.
- In a separate flask, dissolve AMMA, MMA, EBiB, and PMDETA in anisole.
- Degas the monomer/initiator/ligand solution by bubbling with nitrogen for 30 minutes.
- Transfer the degassed solution to the Schlenk flask containing CuBr via a nitrogen-purged syringe.
- Place the flask in a thermostated oil bath at a specified temperature (e.g., 60-90 °C).
- Monitor the polymerization by taking samples at regular intervals to determine monomer conversion via ^1H NMR or gas chromatography.
- Once the desired conversion is reached, stop the polymerization by cooling the flask in an ice bath and exposing the reaction mixture to air.
- Dilute the mixture with a suitable solvent (e.g., THF) and pass it through a short column of neutral alumina to remove the copper catalyst.
- Precipitate the polymer in a large excess of cold methanol.
- Filter and dry the polymer under vacuum.

Reversible Addition-Fragmentation chain-Transfer (RAFT) Polymerization

RAFT polymerization is another versatile controlled radical polymerization technique that is tolerant to a wide range of functional monomers. The choice of RAFT agent is crucial for successful polymerization. For the copolymerization of **9-vinylanthracene**, a universal RAFT agent or one specifically designed for less-activated monomers might be necessary.

Conceptual Protocol: RAFT Copolymerization of **9-Vinylanthracene** and an Acrylic Monomer

This generalized protocol outlines the steps for a RAFT copolymerization.

Materials:

- **9-Vinylanthracene** (9-VA)
- Acrylic monomer (e.g., methyl acrylate)
- RAFT agent (e.g., a trithiocarbonate or dithiobenzoate)
- AIBN (initiator)
- Anhydrous solvent (e.g., dioxane or toluene)
- Precipitating solvent (e.g., methanol or hexane)

Procedure:

- In a Schlenk tube, dissolve 9-VA, the acrylic monomer, the RAFT agent, and AIBN in the anhydrous solvent. The molar ratio of monomer:RAFT agent:initiator will determine the target molecular weight.
- Subject the solution to three freeze-pump-thaw cycles.
- Place the sealed tube in a preheated oil bath at a temperature suitable for the decomposition of AIBN (typically 60-80 °C).
- Allow the polymerization to proceed for the desired time.

- Quench the reaction by rapid cooling and exposure to air.
- Precipitate the polymer by adding the reaction solution dropwise into a stirred, cold non-solvent.
- Collect the polymer by filtration and dry it in a vacuum oven.

Properties of 9-Vinylanthracene-Based Copolymers

The properties of **9-vinylanthracene**-based copolymers are highly dependent on the comonomer used, the copolymer composition, and the polymer architecture.

Data Presentation

Table 1: Molecular Weight and Thermal Properties of Representative **9-Vinylanthracene** Copolymers

Copolymer System	Polymerization Method	9-VA in Copolymer (mol%)	Mn (g/mol)	PDI (Mw/Mn)	Tg (°C)
P(9-VA-co-St)	Free Radical	10	15,000	2.1	105
P(9-VA-co-MMA)	ATRP (conceptual)	25	25,000	1.3	115
P(9-VA-co-BA)	RAFT (conceptual)	15	30,000	1.2	N/A

Note: The data presented in this table is illustrative and based on typical values found in the literature for similar systems. Actual values will vary depending on the specific reaction conditions.

Table 2: Photophysical Properties of Representative **9-Vinylanthracene** Copolymers in Solution

Copolymer System	Solvent	λ_{abs} (nm)	λ_{em} (nm)	Quantum Yield (Φ)
P(9-VA-co-St)	Toluene	365, 385, 407	415, 438	~0.7
P(9-VA-co-MMA)	THF	366, 386, 408	418, 440	~0.8

Note: λ_{abs} and λ_{em} refer to the absorption and emission maxima, respectively. The characteristic vibronic structure of the anthracene chromophore is often observed in the spectra.

Applications in Organic Electronics

Copolymers based on **9-vinylanthracene** are promising materials for organic light-emitting diodes (OLEDs) due to their blue emission and good film-forming properties. The anthracene moiety can act as a blue emitter or as a host for other fluorescent or phosphorescent dopants.

Table 3: Performance of a Hypothetical OLED Device Incorporating a **9-Vinylanthracene** Copolymer

Device Architecture	Emissive Layer	EQE (%)	Luminous Efficiency (cd/A)	Power Efficiency (lm/W)	CIE (x, y)
ITO/PEDOT:PSS/EML/TPBi/LiF/Al	P(9-VA-co-St)	2.5	3.0	1.5	(0.16, 0.18)

Note: This data is hypothetical and serves as a benchmark for potential device performance. Actual performance will depend on the specific copolymer, device architecture, and fabrication process.

Visualizations

Experimental Workflows

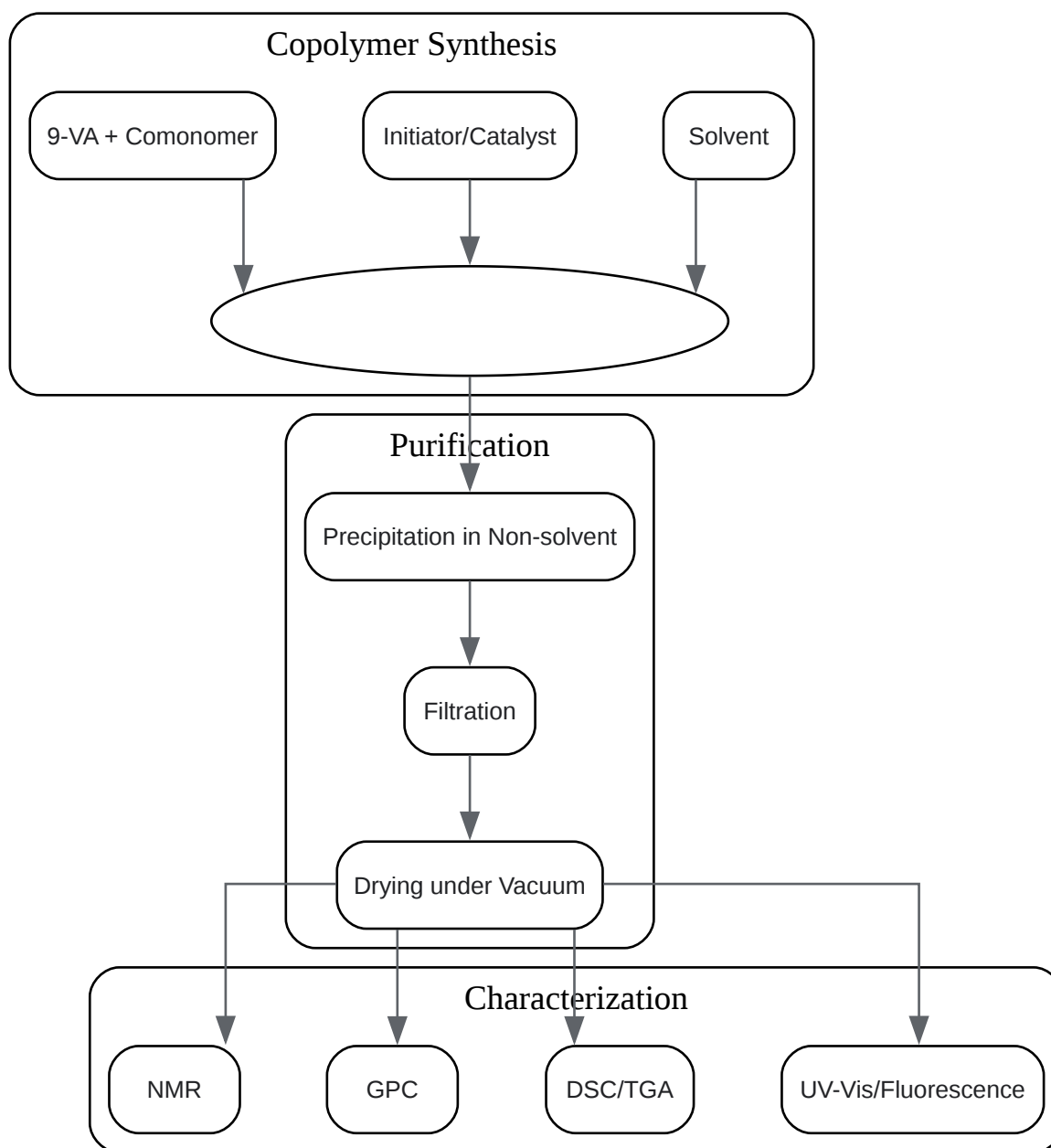

[Click to download full resolution via product page](#)

Caption: General workflow for the synthesis and characterization of **9-vinylanthracene**-based copolymers.

Polymerization Mechanisms

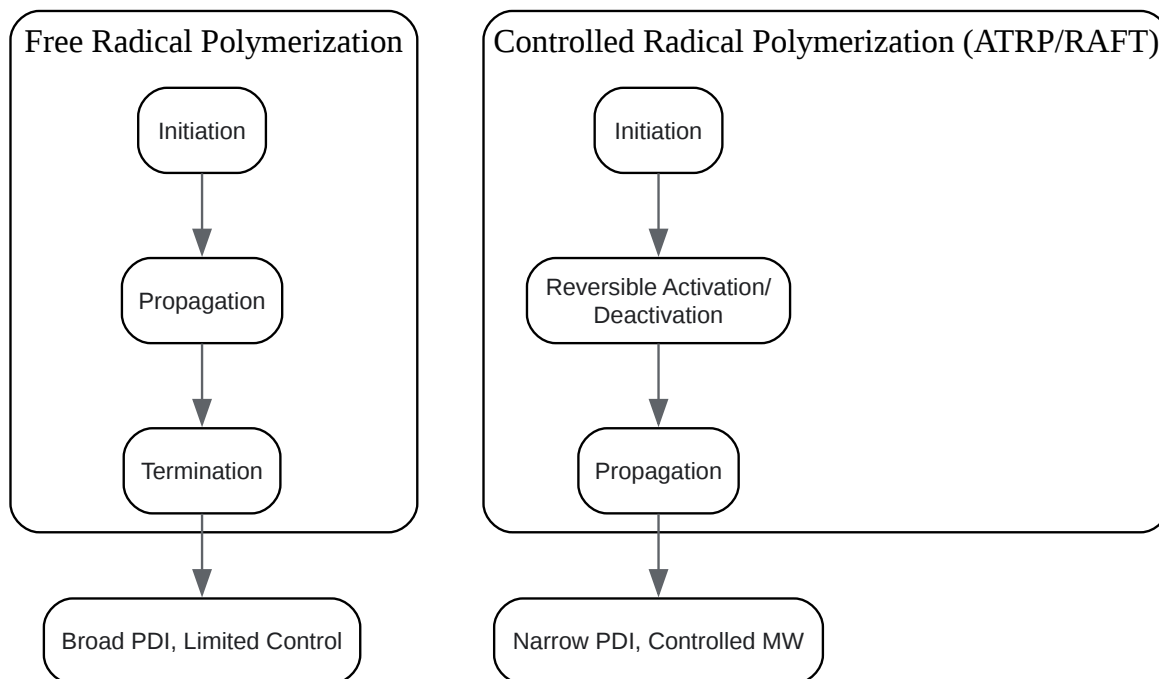

[Click to download full resolution via product page](#)

Caption: Comparison of free radical and controlled radical polymerization mechanisms.

OLED Device Architecture

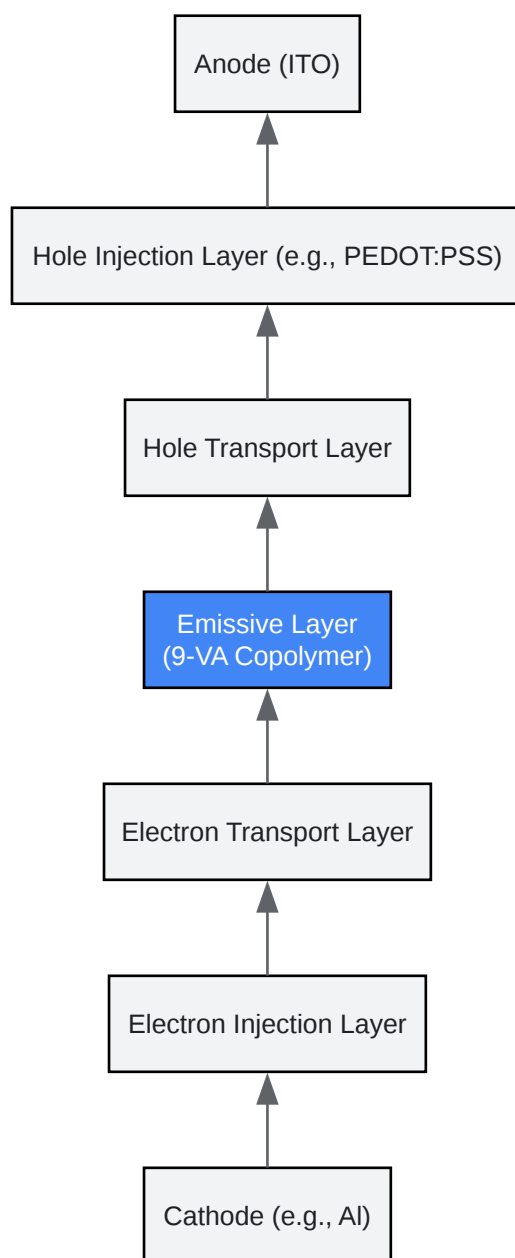

[Click to download full resolution via product page](#)

Caption: A typical multilayer architecture for an OLED device utilizing a **9-vinylanthracene** copolymer as the emissive layer.

Need Custom Synthesis?

BenchChem offers custom synthesis for rare earth carbides and specific isotopic labeling.

Email: info@benchchem.com or [Request Quote Online](#).

References

- 1. The Characterization and Novel Synthesis of Acid Terminated Poly(e-caprolactone) [rusnauka.com]
- To cite this document: BenchChem. [Synthesis and Properties of 9-Vinyanthracene-Based Copolymers: Application Notes and Protocols]. BenchChem, [2025]. [Online PDF]. Available at: [<https://www.benchchem.com/product/b1293765#synthesis-of-9-vinyanthracene-based-copolymers-and-their-properties>]

Disclaimer & Data Validity:

The information provided in this document is for Research Use Only (RUO) and is strictly not intended for diagnostic or therapeutic procedures. While BenchChem strives to provide accurate protocols, we make no warranties, express or implied, regarding the fitness of this product for every specific experimental setup.

Technical Support: The protocols provided are for reference purposes. Unsure if this reagent suits your experiment? [[Contact our Ph.D. Support Team for a compatibility check](#)]

Need Industrial/Bulk Grade? [Request Custom Synthesis Quote](#)

BenchChem

Our mission is to be the trusted global source of essential and advanced chemicals, empowering scientists and researchers to drive progress in science and industry.

Contact

Address: 3281 E Guasti Rd

Ontario, CA 91761, United States

Phone: (601) 213-4426

Email: info@benchchem.com