

# Application Notes and Protocols: Suzuki-Miyaura Cross-Coupling of Halogenated Indazoles

**Author:** BenchChem Technical Support Team. **Date:** December 2025

## Compound of Interest

Compound Name: *3-Bromo-6-chloro-4-nitro-1H-indazole*

Cat. No.: *B1292461*

[Get Quote](#)

For Researchers, Scientists, and Drug Development Professionals

## Introduction

The indazole scaffold is a prominent heterocyclic motif in medicinal chemistry and drug discovery, serving as a bioisostere for indole in numerous biologically active compounds.<sup>[1][2]</sup> Functionalization of the indazole ring is crucial for modulating the pharmacological properties of these molecules. The palladium-catalyzed Suzuki-Miyaura cross-coupling reaction has emerged as a powerful and versatile tool for creating carbon-carbon bonds, enabling the introduction of aryl, heteroaryl, and vinyl groups onto the indazole core.<sup>[3][4][5][6]</sup> This method is favored for its mild reaction conditions, broad substrate scope, and high tolerance of various functional groups.<sup>[4][7]</sup>

These application notes provide a comprehensive overview and detailed protocols for the Suzuki-Miyaura cross-coupling of halogenated indazoles, including bromo-, iodo-, and chloroindazoles. The information is intended to guide researchers in the synthesis of diverse indazole derivatives for applications in drug development and materials science.

## Reaction Mechanism and Key Parameters

The Suzuki-Miyaura reaction involves a catalytic cycle that includes three key steps: oxidative addition, transmetalation, and reductive elimination.<sup>[5]</sup> The choice of catalyst, base, solvent, and the nature of the halogen on the indazole all play critical roles in the efficiency and outcome of the reaction.

- **Halogen Reactivity:** The reactivity of the halogenated indazole follows the general trend for aryl halides: I > Br > Cl.<sup>[8]</sup> While iodo- and bromoindazoles are commonly used, the coupling of chloroindazoles may require more specialized catalytic systems.<sup>[7]</sup>
- **Catalyst:** Palladium catalysts are central to the Suzuki-Miyaura reaction. Commonly used catalysts include Pd(PPh<sub>3</sub>)<sub>4</sub>, PdCl<sub>2</sub>(dppf), and Pd(OAc)<sub>2</sub> with various phosphine ligands.<sup>[1][9][10]</sup> The choice of ligand can significantly influence the reaction's success, especially for less reactive chloroindazoles.<sup>[7]</sup>
- **Base:** An appropriate base is required to activate the organoboron species. Inorganic bases such as K<sub>2</sub>CO<sub>3</sub>, Cs<sub>2</sub>CO<sub>3</sub>, and K<sub>3</sub>PO<sub>4</sub> are frequently employed.<sup>[1][9][11]</sup> The choice of base can affect the reaction rate and yield.
- **Solvent:** A variety of organic solvents can be used, often in combination with water. Common solvent systems include dioxane/water, DME/water, and toluene/ethanol/water.<sup>[1][5][9]</sup>
- **Protecting Groups:** The presence of a free N-H group in the indazole can sometimes inhibit the reaction.<sup>[7]</sup> N-protection (e.g., with Boc, SEM, or alkyl groups) can be beneficial, although successful couplings of unprotected indazoles have also been reported, particularly with microwave assistance.<sup>[9][12]</sup>

## Reaction Condition Optimization Data

The following tables summarize quantitative data from various studies on the Suzuki-Miyaura cross-coupling of halogenated indazoles, providing a comparative overview of different reaction conditions and their outcomes.

Table 1: Suzuki-Miyaura Coupling of 3-Halogenated Indazoles

Halogenated Indazole	Boronic Acid/Ester	Catalyst (mol%)	Base	Solvent	Temp. (°C)	Time (h)	Yield (%)	Reference
3-Iodo-1H-indazole	Pinacol vinyl boronate	Pd(PPh <sub>3</sub> ) <sub>4</sub> (5)	K <sub>2</sub> CO <sub>3</sub>	Dioxane	120 (MW)	0.67	75	[3]
3-Bromo-1H-indazole	Phenylboronic acid	Pd(PPh <sub>3</sub> ) <sub>4</sub> (5)	Cs <sub>2</sub> CO <sub>3</sub>	Dioxane/EtOH/H <sub>2</sub> O	140 (MW)	1	78	[12]
3-Chloro-1H-indazole	Phenylboronic acid	Pd <sub>2</sub> (dba) <sub>3</sub> /SPhos	K <sub>3</sub> PO <sub>4</sub>	Dioxane/H <sub>2</sub> O	100	20	65	[7]
3-Iodo-5-nitro-1H-indazole	Pinacol vinyl boronate	Pd(PPh <sub>3</sub> ) <sub>4</sub> (5)	K <sub>2</sub> CO <sub>3</sub>	Dioxane	120 (MW)	0.67	87	[3]
3-Bromo-5-amino-1H-indazole	4-Methoxyphenylboronic acid	Pd(OAc) <sub>2</sub> /RuPhos	K <sub>3</sub> PO <sub>4</sub>	Dioxane/H <sub>2</sub> O	120 (MW)	0.5	92	[9]

Table 2: Suzuki-Miyaura Coupling of 5-Bromoindazoles

Halogenated Indazole	Boronic Acid	Catalyst (mol%)	Base	Solvent	Temp. (°C)	Time (h)	Yield (%)	Reference
5-Bromo-1-ethyl-1H-indazole	N-Boc-2-pyrroleboronic acid	PdCl <sub>2</sub> (dppf) (5)	K <sub>2</sub> CO <sub>3</sub>	DME	80	2	95	[1]
5-Bromo-1-acetyl-1H-indazole	N-Boc-2-pyrroleboronic acid	PdCl <sub>2</sub> (dppf) (5)	K <sub>2</sub> CO <sub>3</sub>	DME	80	2	45	[1]
5-Bromo-1-ethyl-1H-indazole	2-Thiopheneboronic acid	PdCl <sub>2</sub> (dppf) (5)	K <sub>2</sub> CO <sub>3</sub>	DME	80	2	92	[1]
5-Bromo-1-Boc-1H-indazole	2-Thiopheneboronic acid	PdCl <sub>2</sub> (dppf) (5)	K <sub>2</sub> CO <sub>3</sub>	DME	80	2	85	[1]

Table 3: Suzuki-Miyaura Coupling of 7-Bromoindazoles

Halogenated Indazole	Boronic Acid	Catalyst (mol%)	Base	Solvent	Temp. (°C)	Time (h)	Yield (%)	Reference
N-(7-Bromo-1H-indazol-4-yl)-4-methylbenzenesulfonamide	4-Methoxyphenylboronic acid	Pd(PPh <sub>3</sub> ) <sub>4</sub> (10)	Cs <sub>2</sub> CO <sub>3</sub>	Dioxane/EtOH/H <sub>2</sub> O	140	4	75	[4]
N-(7-Bromo-1H-indazol-4-yl)-4-methylbenzenesulfonamide	4-Formylphenylboronic acid	Pd(PPh <sub>3</sub> ) <sub>4</sub> (10)	Cs <sub>2</sub> CO <sub>3</sub>	Dioxane/EtOH/H <sub>2</sub> O	140	4	68	[4]
N-(7-Bromo-1H-indazol-4-yl)-4-methylbenzenesulfonamide	2-Thiopheneboronic acid	Pd(PPh <sub>3</sub> ) <sub>4</sub> (10)	Cs <sub>2</sub> CO <sub>3</sub>	Dioxane/EtOH/H <sub>2</sub> O	140	4	62	[4]
N-(7-Bromo-1H-indazol-4-yl)-4-methylbenzenesulfonamide	4-Methylphenylboronic acid	Pd(PPh <sub>3</sub> ) <sub>4</sub> (10)	Cs <sub>2</sub> CO <sub>3</sub>	Dioxane/EtOH/H <sub>2</sub> O	140	4	72	[4]

4-yl)-4- ronic  
methylb acid  
enzene  
sulfona  
mide

---

## Experimental Protocols

### Protocol 1: Microwave-Assisted Suzuki-Miyaura Coupling of 3-Iodo-1H-indazole with Pinacol Vinyl Boronate[3]

This protocol describes the C-3 vinylation of unprotected 3-iodoindazole.

Materials:

- 3-Iodo-1H-indazole
- Pinacol vinyl boronate
- Tetrakis(triphenylphosphine)palladium(0) [Pd(PPh<sub>3</sub>)<sub>4</sub>]
- Potassium carbonate (K<sub>2</sub>CO<sub>3</sub>)
- 1,4-Dioxane

Procedure:

- To a microwave vial, add 3-iodo-1H-indazole (1.0 equiv), pinacol vinyl boronate (2.0 equiv), Pd(PPh<sub>3</sub>)<sub>4</sub> (0.05 equiv), and K<sub>2</sub>CO<sub>3</sub> (2.0 equiv).
- Add 1,4-dioxane to the vial.
- Seal the vial and place it in a microwave reactor.
- Irradiate the reaction mixture at 120 °C for 40 minutes.
- After completion, cool the reaction mixture to room temperature.

- Dilute the mixture with a suitable organic solvent (e.g., ethyl acetate) and wash with water.
- Dry the organic layer over anhydrous sodium sulfate, filter, and concentrate under reduced pressure.
- Purify the crude product by column chromatography on silica gel to afford the desired 3-vinyl-1H-indazole.

## Protocol 2: Suzuki-Miyaura Coupling of 5-Bromo-1-ethyl-1H-indazole with N-Boc-2-pyrroleboronic Acid[1]

This protocol details the coupling at the C-5 position of an N-alkylated indazole.

Materials:

- 5-Bromo-1-ethyl-1H-indazole
- N-Boc-2-pyrroleboronic acid
- [1,1'-Bis(diphenylphosphino)ferrocene]palladium(II) dichloride [PdCl<sub>2</sub>(dppf)]
- Potassium carbonate (K<sub>2</sub>CO<sub>3</sub>)
- 1,2-Dimethoxyethane (DME)

Procedure:

- In a reaction flask, combine 5-bromo-1-ethyl-1H-indazole (1.0 equiv), N-Boc-2-pyrroleboronic acid (1.2 equiv), PdCl<sub>2</sub>(dppf) (0.05 equiv), and K<sub>2</sub>CO<sub>3</sub> (2.0 equiv).
- Add DME to the flask.
- Heat the reaction mixture at 80 °C under an inert atmosphere (e.g., nitrogen or argon) for 2 hours.
- Monitor the reaction progress by thin-layer chromatography (TLC).
- Once the starting material is consumed, cool the reaction to room temperature.

- Filter the mixture through a pad of Celite and wash with an organic solvent.
- Concentrate the filtrate under reduced pressure.
- Purify the residue by flash column chromatography to yield the coupled product.

### Protocol 3: Suzuki-Miyaura Coupling of N-(7-Bromo-1H-indazol-4-yl)-4-methylbenzenesulfonamide with (4-Methoxyphenyl)boronic Acid[4]

This protocol describes the C-7 arylation of a 4-substituted NH-free indazole.

Materials:

- N-(7-Bromo-1H-indazol-4-yl)-4-methylbenzenesulfonamide
- (4-Methoxyphenyl)boronic acid
- Tetrakis(triphenylphosphine)palladium(0) [Pd(PPh<sub>3</sub>)<sub>4</sub>]
- Cesium carbonate (Cs<sub>2</sub>CO<sub>3</sub>)
- 1,4-Dioxane, Ethanol, Water mixture (e.g., 3:1.5:0.5)

Procedure:

- In a sealed tube, place N-(7-bromo-1H-indazol-4-yl)-4-methylbenzenesulfonamide (1.0 equiv), (4-methoxyphenyl)boronic acid (1.2 equiv), Pd(PPh<sub>3</sub>)<sub>4</sub> (0.10 equiv), and Cs<sub>2</sub>CO<sub>3</sub> (1.3 equiv).
- Add the dioxane/ethanol/water solvent mixture.
- Seal the tube and heat the reaction mixture at 140 °C for 4 hours.
- After cooling, dilute the reaction mixture with water and extract with an organic solvent (e.g., ethyl acetate).
- Combine the organic layers, dry over anhydrous sodium sulfate, and concentrate in vacuo.



- Purify the crude product by column chromatography to obtain the C-7 arylated indazole.

## Visualizations

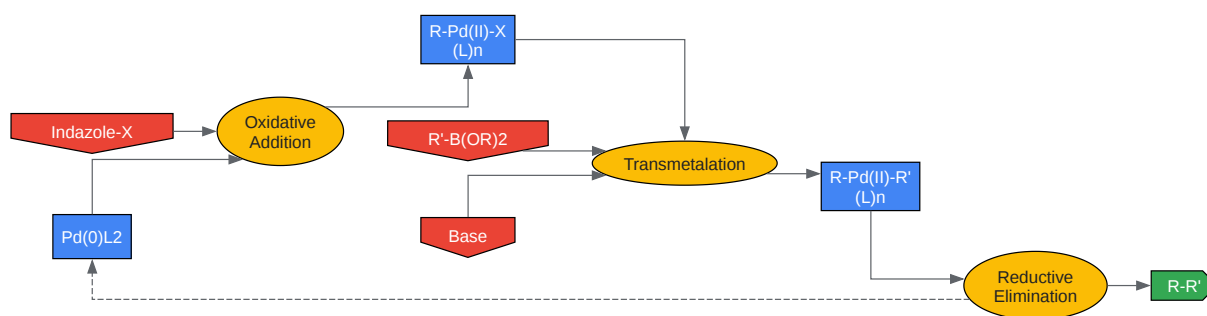

[Click to download full resolution via product page](#)

Caption: General catalytic cycle for the Suzuki-Miyaura cross-coupling reaction.

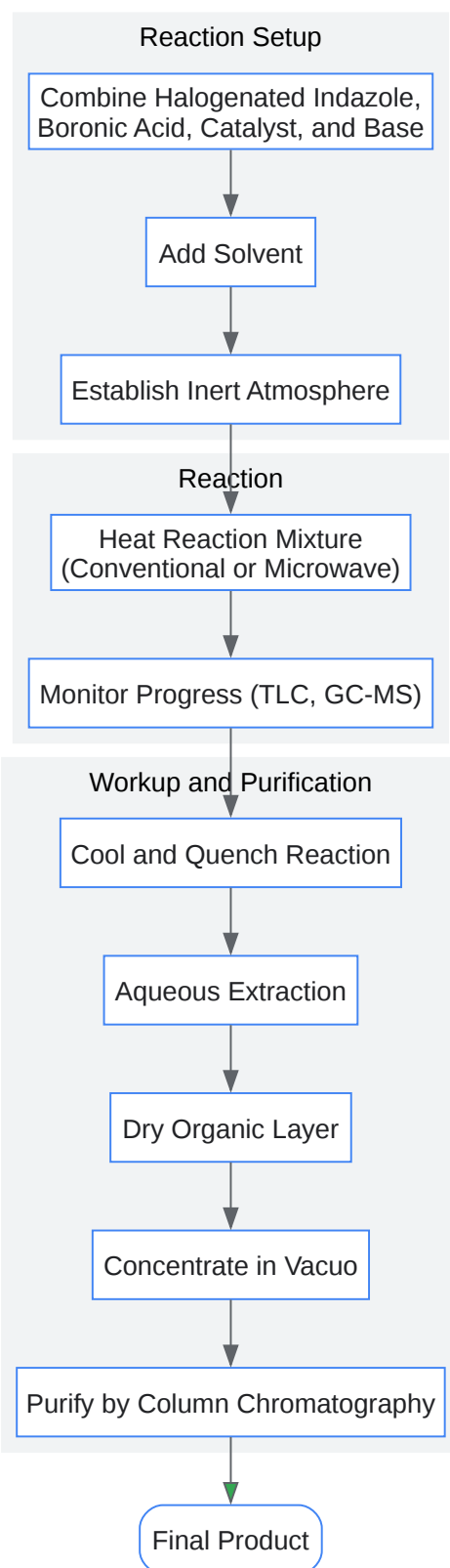

[Click to download full resolution via product page](#)

Caption: A typical experimental workflow for the Suzuki-Miyaura cross-coupling of halogenated indazoles.

### Need Custom Synthesis?

BenchChem offers custom synthesis for rare earth carbides and specific isotopic labeling.

Email: [info@benchchem.com](mailto:info@benchchem.com) or [Request Quote Online](#).

## References

- 1. The Suzuki Reaction Applied to the Synthesis of Novel Pyrrolyl and Thiophenyl Indazoles - PMC [pmc.ncbi.nlm.nih.gov]
- 2. Synthesis of 3-aryl-1 H -indazoles via iridium-catalysed C–H borylation and Suzuki–Miyaura coupling - RSC Advances (RSC Publishing) DOI:10.1039/C4RA04235B [pubs.rsc.org]
- 3. Suzuki-Type Cross-Coupling Reaction of Unprotected 3-Iodoindazoles with Pinacol Vinyl Boronate: An Expeditive C-3 Vinylation of Indazoles under Microwave Irradiation - PMC [pmc.ncbi.nlm.nih.gov]
- 4. A regioselective C7 bromination and C7 palladium-catalyzed Suzuki–Miyaura cross-coupling arylation of 4-substituted NH-free indazoles - PMC [pmc.ncbi.nlm.nih.gov]
- 5. An efficient and simple approach for synthesizing indazole compounds using palladium-catalyzed Suzuki–Miyaura cross-coupling - RSC Advances (RSC Publishing) DOI:10.1039/D4RA04633A [pubs.rsc.org]
- 6. researchgate.net [researchgate.net]
- 7. Suzuki-Miyaura Cross-Coupling of Unprotected, Nitrogen-Rich Heterocycles: Substrate Scope and Mechanistic Investigation - PMC [pmc.ncbi.nlm.nih.gov]
- 8. Yoneda Labs [yonedalabs.com]
- 9. researchgate.net [researchgate.net]
- 10. The C-3 Functionalization of 1H-Indazole through Suzuki–Miyaura Cross-Coupling Catalyzed by a Ferrocene-Based Divalent Palladium Complex Immobilized over Ionic Liquid, as Well as Theoretical Insights into the Reaction Mechanism [mdpi.com]
- 11. researchgate.net [researchgate.net]
- 12. researchgate.net [researchgate.net]

- To cite this document: BenchChem. [Application Notes and Protocols: Suzuki-Miyaura Cross-Coupling of Halogenated Indazoles]. BenchChem, [2025]. [Online PDF]. Available at: [<https://www.benchchem.com/product/b1292461#suzuki-miyaura-cross-coupling-of-halogenated-indazoles>]

---

**Disclaimer & Data Validity:**

The information provided in this document is for Research Use Only (RUO) and is strictly not intended for diagnostic or therapeutic procedures. While BenchChem strives to provide accurate protocols, we make no warranties, express or implied, regarding the fitness of this product for every specific experimental setup.

**Technical Support:** The protocols provided are for reference purposes. Unsure if this reagent suits your experiment? [[Contact our Ph.D. Support Team for a compatibility check](#)]

**Need Industrial/Bulk Grade?** [Request Custom Synthesis Quote](#)

## BenchChem

Our mission is to be the trusted global source of essential and advanced chemicals, empowering scientists and researchers to drive progress in science and industry.

### Contact

Address: 3281 E Guasti Rd  
Ontario, CA 91761, United States  
Phone: (601) 213-4426  
Email: [info@benchchem.com](mailto:info@benchchem.com)