

Technical Guide: 3-Bromo-6-methylchromone (CAS 102653-68-9)

Author: BenchChem Technical Support Team. **Date:** May 2026

Compound of Interest

Compound Name: 3-Bromo-6-methylchromone

CAS No.: 102653-68-9

Cat. No.: B1290892

[Get Quote](#)

Executive Summary

3-Bromo-6-methylchromone (CAS 102653-68-9) is a halogenated heterocyclic building block belonging to the chromone (4H-1-benzopyran-4-one) family. Distinguished by a bromine atom at the C-3 position and a methyl group at the C-6 position, this molecule serves as a critical "linchpin" intermediate in the synthesis of complex bioactive scaffolds, particularly isoflavones (3-arylchromones) and functionalized flavonoids.

Unlike simple chromones, the C-3 bromine substituent activates the molecule for transition-metal-catalyzed cross-coupling reactions (Suzuki-Miyaura, Sonogashira, Heck), allowing for the rapid diversification of the core scaffold. This guide details the physicochemical properties, validated synthetic pathways, and reactivity profiles necessary for utilizing this compound in drug discovery.^{[1][2][3]}

Chemical Identity & Physicochemical Properties^[3] ^{[4][5][6][7][8][9][10]}

The following data establishes the baseline identity for **3-Bromo-6-methylchromone**. Researchers should verify incoming raw materials against these specifications.

Property	Specification
CAS Number	102653-68-9
IUPAC Name	3-Bromo-6-methyl-4H-chromen-4-one
Molecular Formula	
Molecular Weight	239.07 g/mol
SMILES	<chem>CC1=CC2=C(C=C1)OC=C(C2=O)Br</chem>
Appearance	Off-white to pale yellow crystalline solid
Solubility	Soluble in DMSO, DMF, , ; Insoluble in water
Melting Point	Typically 108–112 °C (Derivative dependent; verify experimentally)
Reactivity Class	Electrophile (Michael acceptor); Aryl/Vinyl halide equivalent

Synthetic Pathways[4][12][13][14]

The synthesis of **3-Bromo-6-methylchromone** is typically achieved through the electrophilic halogenation of the parent 6-methylchromone. This process must be controlled to prevent over-bromination or ring opening.[3]

Primary Synthetic Route: Electrophilic Bromination / Elimination[3]

This protocol relies on the addition of bromine across the C2-C3 double bond, followed by base-mediated dehydrohalogenation to restore aromaticity.

Reagents:

- Precursor: 6-Methylchromone (CAS 38443-18-6)
- Halogen Source: Bromine () or N-Bromosuccinimide (NBS)
- Solvent: or Acetic Acid ()
- Base (for elimination): Triethylamine () or Pyridine

Step-by-Step Protocol (Self-Validating):

- Dissolution: Dissolve 1.0 eq of 6-methylchromone in dry (0.5 M concentration). Ensure the reaction vessel is shielded from direct light if using to minimize radical side reactions at the methyl group.[3]
- Bromination: Cool to 0°C. Dropwise add 1.05 eq of dissolved in .
 - Checkpoint: The solution should transition from clear to reddish-brown, then fade as the bromine is consumed (forming the 2,3-dibromo intermediate).
- Elimination: Once the starting material is consumed (monitor by TLC, typically 1-2 hours), add 1.2 eq of dropwise.[3]

- Mechanism:[4][5] The base eliminates HBr, restoring the C2-C3 double bond and yielding the 3-bromo product.
- Workup: Wash the organic layer with 1M HCl (to remove amine salts), followed by saturated and brine. Dry over .[3]
- Purification: Recrystallize from ethanol or purify via flash column chromatography (Hexane/EtOAc gradient).

Synthetic Logic Visualization[3]

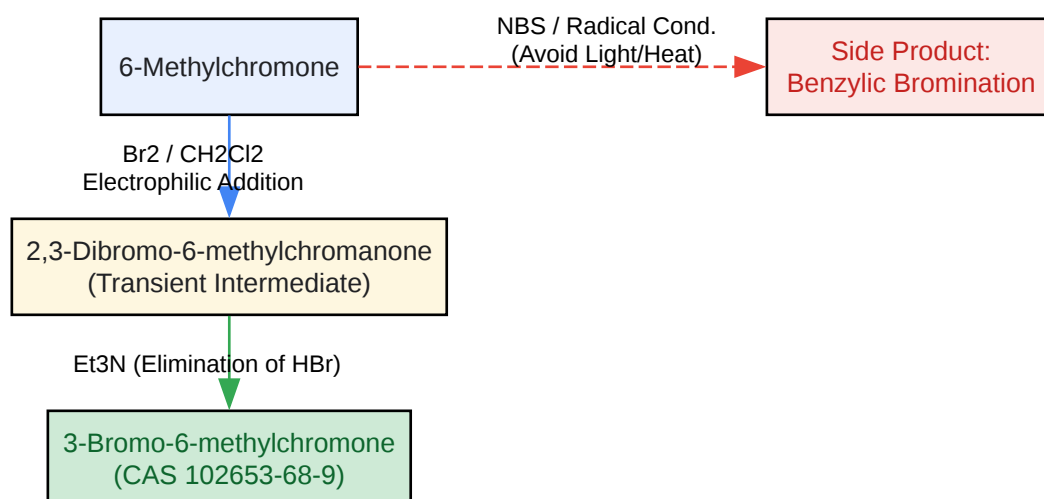

[Click to download full resolution via product page](#)

Figure 1: Step-wise synthesis of **3-Bromo-6-methylchromone** showing the critical intermediate and potential side reaction.

Reactivity & Applications in Drug Design[2][4]

3-Bromo-6-methylchromone is a "privileged scaffold" precursor.[3] Its reactivity is defined by two distinct electrophilic sites:

- C-3 Position (Bromine): A handle for Palladium-catalyzed cross-coupling.[3]

- C-2 Position: Susceptible to nucleophilic attack (Michael addition), leading to ring-opening or heterocycle formation (e.g., pyrazoles).[3]

The Isoflavone Gateway (Suzuki-Miyaura Coupling)

The most high-value application is the synthesis of 6-methylisoflavones (3-phenylchromones), which are potent estrogen receptor modulators and kinase inhibitors.

General Protocol:

- Substrates: **3-Bromo-6-methylchromone** + Aryl Boronic Acid ().
- Catalyst:
(5 mol%) or
/S-Phos.[3]
- Base:
or
(2.0 eq).[3]
- Solvent: Dioxane/Water (4:1) or Toluene/EtOH.[3]
- Conditions: 80-100°C, 4-12 hours under Argon.

Reactivity Workflow Visualization[2][3]

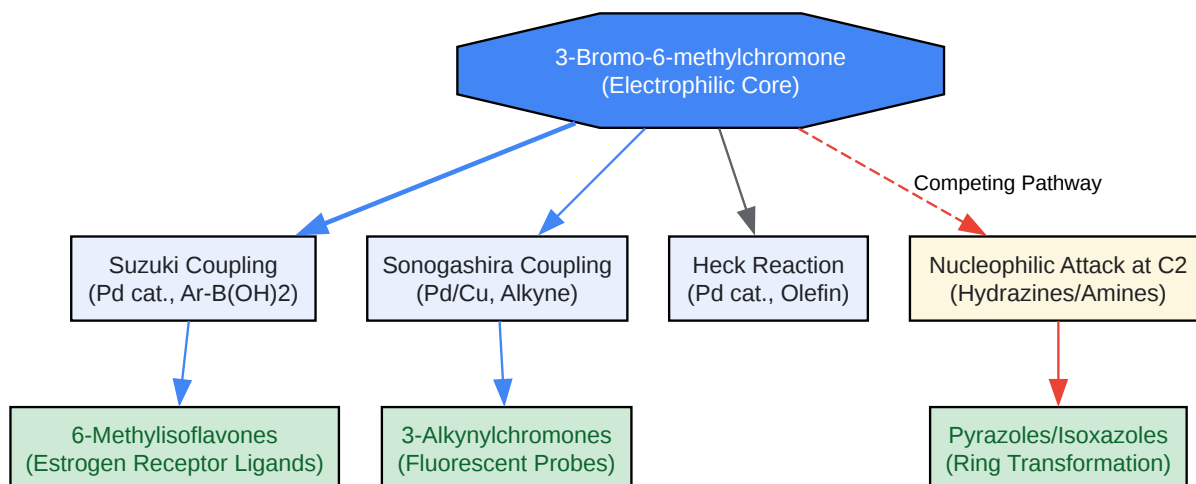

[Click to download full resolution via product page](#)

Figure 2: Divergent reactivity profile.^[3] The blue pathways represent C-3 functionalization (preserving the chromone core), while the red pathway represents C-2 attack (potentially altering the core).

Biological Relevance

The 6-methylchromone motif is pharmacologically significant.^{[3][6]} The addition of the 3-bromo substituent allows researchers to access derivatives with:

- **PI3K Inhibition:** Chromone-based inhibitors often require an aryl group at C-3 to fit the ATP binding pocket of kinases.^[3] The 3-bromo intermediate is the direct precursor to these libraries.^[3]
- **Antioxidant Activity:** 6-methylchromone derivatives have shown efficacy in scavenging reactive oxygen species (ROS), though the 3-bromo derivative itself is usually a pro-drug or intermediate rather than the final active agent.^[3]
- **Neuroprotection:** Substituted chromones are being investigated for neuroprotective effects against oxidative stress-induced cell death.^[3]

Safety and Handling

- Hazards: **3-Bromo-6-methylchromone** is an organic halide and should be treated as an irritant (Skin/Eye/Respiratory).
- Sensitization: Halogenated chromones can be potent skin sensitizers.[3] Double-gloving (Nitrile) is recommended.[3]
- Storage: Store in a cool, dry place (). Protect from light to prevent photochemical debromination or radical degradation.[3]

References

- ChemicalBook. (2025).[3] **3-BROMO-6-METHYLCHROMONE** (CAS 102653-68-9) Product Information.[7] Retrieved from
- Ewies, F., et al. (2014).[3][5] Synthesis of Chromones and Their Applications During the Last Ten Years. International Journal of Research in Pharmacy and Chemistry, 4(4), 1046-1085. [5] Retrieved from
- Gammill, R. B. (1979).[3] General synthesis of 3-substituted chromones.[3][4] Synthesis, 1979(11), 901-903.[3] (Foundational methodology for 3-bromination).[3]
- Horton, D. A., et al. (2003).[3] The Combinatorial Synthesis of Bicyclic Privileged Structures or Privileged Substructures.[3] Chemical Reviews, 103(3), 893-930.[3] (Context on Chromones as privileged scaffolds).
- PubChem. (2025).[3] Compound Summary: 3-Formyl-6-methylchromone (Related Structure).[3] Retrieved from (Note: Used for structural analogy and physical property estimation).

Need Custom Synthesis?

BenchChem offers custom synthesis for rare earth carbides and specific isotopic labeling.

Email: info@benchchem.com or [Request Quote Online](#).

Sources

- [1. pdf.benchchem.com \[pdf.benchchem.com\]](https://pdf.benchchem.com)
- [2. pdf.benchchem.com \[pdf.benchchem.com\]](https://pdf.benchchem.com)
- [3. 3-Formyl-6-methylchromone | C11H8O3 | CID 688709 - PubChem \[pubchem.ncbi.nlm.nih.gov\]](https://pubchem.ncbi.nlm.nih.gov)
- [4. asianpubs.org \[asianpubs.org\]](https://asianpubs.org)
- [5. ijrpc.com \[ijrpc.com\]](https://ijrpc.com)
- [6. chemimpex.com \[chemimpex.com\]](https://chemimpex.com)
- [7. lookchem.com \[lookchem.com\]](https://lookchem.com)
- To cite this document: BenchChem. [Technical Guide: 3-Bromo-6-methylchromone (CAS 102653-68-9)]. BenchChem, [2026]. [Online PDF]. Available at: [\[https://www.benchchem.com/product/b1290892/docs#technical-guide-3-bromo-6-methylchromone-cas-102653-68-9\]](https://www.benchchem.com/product/b1290892/docs#technical-guide-3-bromo-6-methylchromone-cas-102653-68-9)

Disclaimer & Data Validity:

The information provided in this document is for Research Use Only (RUO) and is strictly not intended for diagnostic or therapeutic procedures. While BenchChem strives to provide accurate protocols, we make no warranties, express or implied, regarding the fitness of this product for every specific experimental setup.

Technical Support: The protocols provided are for reference purposes. Unsure if this reagent suits your experiment?

Need Industrial/Bulk Grade? [Request Custom Synthesis Quote](#)

BenchChem

Our mission is to be the trusted global source of essential and advanced chemicals, empowering scientists and researchers to drive progress in science and industry.

Contact

Address: 3281 E Guasti Rd

Ontario, CA 91761, United States

Phone: (601) 213-4426

Email: info@benchchem.com

Contact our Ph.D. Support Team for a compatibility check